

Centre Number	Candidate Number	Name
---------------	------------------	------

UNIVERSITY OF CAMBRIDGE INTERNATIONAL EXAMINATIONS
General Certificate of Education
Advanced Subsidiary Level and Advanced Level

BIOLOGY

9700/31

Paper 31 Advanced Practical Skills

For Examination from 2007

Specimen Paper

2 hours

Candidates answer on the Question Paper.

Additional Materials: As listed in Instructions to Supervisors.

READ THESE INSTRUCTIONS FIRST

Write your Centre number, candidate number and name on all the work you hand in.

Write in dark blue or black pen.

Do not use staples, paper clips, highlighters, glue or correction fluid.

You may use a pencil for any diagrams, graphs or rough working.

Answer **all** questions.

At the end of the examination, fasten all your work securely together.

The number of marks is given in brackets [] at the end of each question or part question.

This document consists of **11** printed pages and **1** blank page.



- 1 You are reminded that you have only one hour for this part of the practical examination. You should read carefully through the whole of this question and then plan your use of the time to make sure that you finish all the work that you would like to do.

Respiration is a process which uses enzymes to release energy from biological molecules.

- (a) You should spend no longer than five minutes on question 1 (a).

You are provided with a solution of a biological molecule, **S1**. You are provided with the following materials that can be used to identify the biological molecule in solution **S1**.

- Ethanol
- Benedict's solution
- Distilled water

Use the materials provided to identify the biological molecule in solution **S1**.

Describe each test that you performed and explain the meaning of the results that you obtained.

.....
.....
.....
.....
.....
..... [2]

- (b) You should spend no more than 25 minutes on question 1 (b)

You are provided with a suspension of yeast that has been placed in solution S1, labelled **S2**.

Carefully follow the instructions below to use **S2** to investigate the quantitative effect of temperature on the enzymes in the yeast. You should present and record your observations and data in the space provided.

You will need to:

- read through the instructions carefully,
- make some decisions,
- prepare the space on the next page so that it is ready for you to record the readings.

- Place 10 cm³ of suspension **S2** into the large test-tube.
- Securely fit the bung with the delivery tube into the top of the large test-tube
- Place 5 cm³ of distilled water in an empty test-tube, **A**.
- Place 150 cm³ of water in the beaker.
- Measure the temperature of the water.
- Use the beaker as a water bath for the large test-tube, so that the delivery tube is outside the beaker
- Place test-tube **A** so that the end of the delivery tube is near the bottom of the water in test-tube **A**, as shown in Fig 1.1.
-

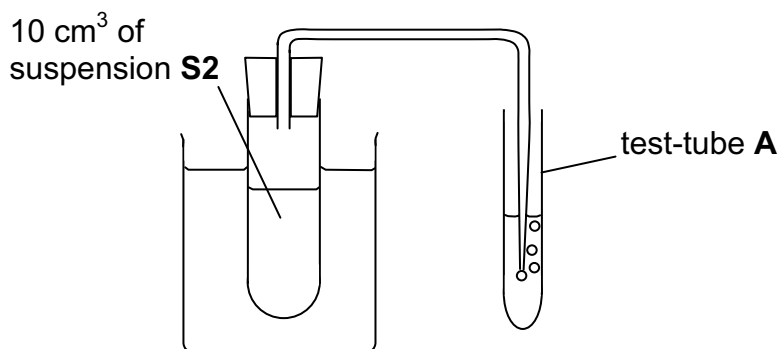

Fig 1.1

Bubbles of gas should come from the end of the delivery tube.

- (i) Decide how many readings to take, and for how long to take each reading. Each reading should be made and recorded in the space you have prepared below. [1]
- (ii) You can use the Bunsen burner to warm up the water in the water bath. Decide how many different temperatures you will use, and what would be appropriate temperatures to use. Repeat the readings taken in (i) at each of your chosen temperatures.

[6]

- (c) (i) pH has a big effect on the rate of enzyme reactions. Suggest how effectively pH was controlled in this experiment.

.....
 [1]

- (ii) State **two** significant sources of error in this experiment, other than control of pH.

.....

 [1]

- (d) In a student's investigation the number of bubbles of gas produced in five minutes was measured. The data in Table 1.1 was obtained.

Table 1.1

temperature/°C	bubbles of gas produced in 5 minutes			mean number of bubbles of gas/ bubbles min ⁻¹
	first run	second run	third run	
28	10	8	11	1.9
38	19	21	17	3.8
48	24	21	28	
58	11	6	10	1.8

- (i) The first time that the student tried this at 38 °C, the number of bubbles produced in five minutes was 3 cm³. Explain why the student discarded the reading and repeated it.

.....
 [1]

- (ii) Complete Table 1.1 by calculating the missing value for the mean number of gas bubbles produced per minute, at 48 °C.

Show your working in the space below

[1]

(iii) Plot a graph to show the effect of temperature on the mean number of gas bubbles produced, using the data in Table 1.1.

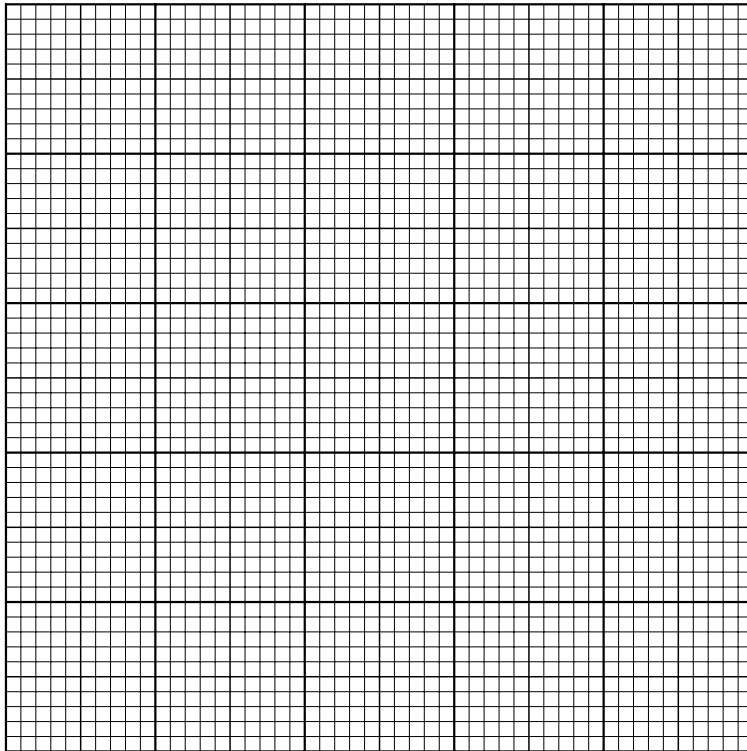

[3]

(e) Briefly outline the main features of the relationship between temperature and mean volume of gas produced.

.....

.....

.....

[1]

(f) The student's hypothesis was

- as the temperature increases, the rate of production of gas will increase

Draw an appropriate conclusion to the student's experiment, including

- whether the experimental data supports the student's hypothesis,
- a revised or new prediction.

.....

.....

.....

.....

.....

.....

..... [2]

(g) Suggest how the experiment in question 1 (a) could be improved.

.....

.....

.....

.....

.....

.....

..... [2]

- 2 You are reminded that you have only one hour for this part of the practical examination. You should read carefully through the whole of this question and then plan your use of the time to make sure that you finish all the work that you would like to do.

(a) (i) Draw a low power plan diagram of the specimen on slide **S4**

[2]

- (ii) Use a ruler to measure the actual size of the specimen on slide S4 and the size of your drawing across the same point. Draw a line on your drawing to show the size that you have measured. Calculate the magnification of your drawing.

Show your working

magnification [2]

- (iii) Estimate the uncertainty in the measurement of the actual size of the specimen on slide **S4**.

Actual size measured =

Uncertainty = [1]

(iv) Suggest how a systematic error in measuring the size could occur.

.....
.....
..... [1]

(b) Starch is stored as granules in some of the cells in the specimen on slide **S4**. Starch is stained purple during preparation of slide **S4**.

In the space below, show your observations of enough of these food storage cells to give a representative sample of the range of their structure.

[6]

(c) (i) Prepare the space below so that it is suitable for you to compare, using a hand lens and microscope, specimen **S3** and the specimen on slide **S4**.

[1]

(ii) Compare specimen **S3** and the specimen on slide **S4**, recording your observations in the space that you prepared in question 2 (c) (i). [3]

(iii) Both specimens are involved in transport of materials. State one key point of your observations that relates to this function.

.....
.....
..... [1]

(d) The photomicrographs, Fig. 2.1 and Fig. 2.2 are taken from a different part of an unfamiliar plant. Fig. 2.1 is a transverse section across the structure, and Fig. 2.2 is a longitudinal section along it.

Mature xylem vessels are large tubes with thick cell walls and no cytoplasm within them. As they mature the cells die, the end walls of the cells break down and they become a continuous tube. They are found within vascular bundles that run along roots, stems and inside the veins of leaves. They do not have companion cells. The cell walls of the xylem vessels or the cells next to them may have rings or spirals of thickening, and may have pits, which are holes through the cell walls connecting cells with the cell next to them.

Use clear labels and label lines to show the xylem in each of the photomicrographs using the information provided. Explain the reasons for your choice in the space provided.

Reasons for choice

.....

.....

.....

.....

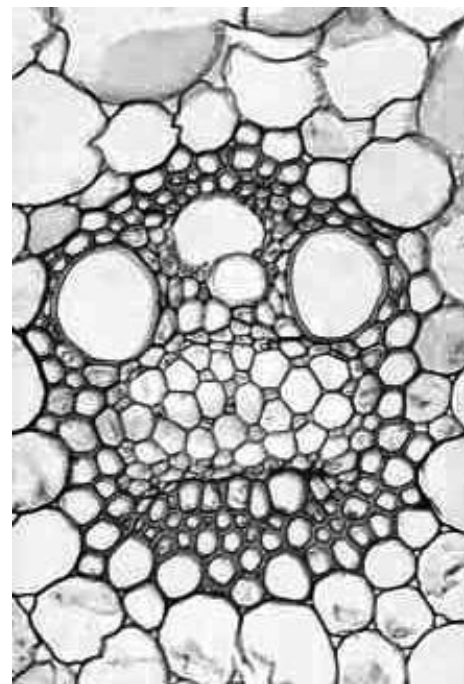

Fig. 2.1

Reasons for choice

.....

.....

.....

.....

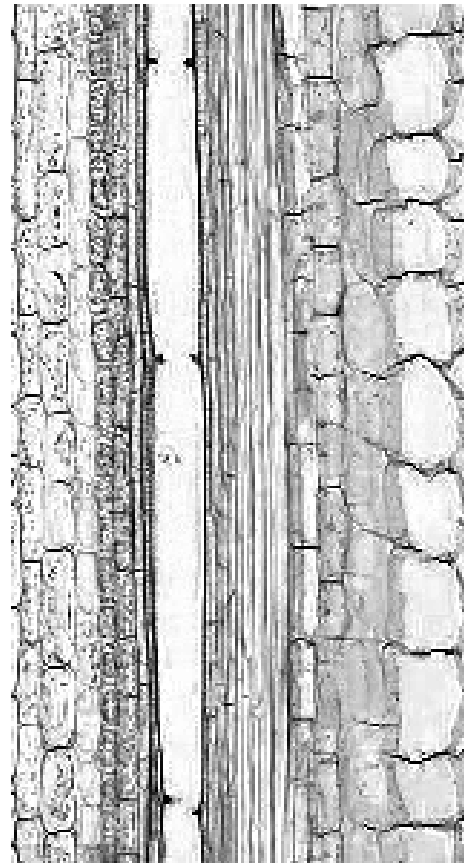

Fig. 2.2

[2]

BLANK PAGE

Copyright Acknowledgements:

Question 2 Fig. 2.2 © <http://www.lima.ohio-state.edu/academics/biology/images/cornstems.jpg>

Permission to reproduce items where third-party owned material protected by copyright is included has been sought and cleared where possible. Every reasonable effort has been made by the publisher (UCLES) to trace copyright holders, but if any items requiring clearance have unwittingly been included, the publisher will be pleased to make amends at the earliest possible opportunity.

University of Cambridge International Examinations is part of the Cambridge Assessment Group. Cambridge Assessment is the brand name of University of Cambridge Local Examinations Syndicate (UCLES), which is itself a department of the University of Cambridge.

Centre Number	Candidate Number	Name
---------------	------------------	------

UNIVERSITY OF CAMBRIDGE INTERNATIONAL EXAMINATIONS
General Certificate of Education
Advanced Subsidiary Level and Advanced Level

BIOLOGY

9700/31

Paper 31 Advanced Practical Skills

For Examination from 2007

SPECIMEN INSTRUCTIONS

Great care should be taken that any information given does not reach the candidates either directly or indirectly.

This document consists of **4** printed pages.



UNIVERSITY of CAMBRIDGE
International Examinations

Instructions for preparing apparatus

These instructions give details of the apparatus and materials required by each candidate for this paper. Sufficient information is given to permit the Centre to set up and test the apparatus and materials so that the candidates can be fairly assessed.

If a candidate breaks any of the apparatus, or loses any of the material supplied, the matter should be rectified.

Candidates must be provided with a microscope with:

- Low-power objective lens, e.g. X10 (equal to 16 mm or $\frac{2}{3}$ ")
- High-power objective lens, e.g. X40 (equal to 4 mm or $\frac{1}{6}$ ")
- Eyepiece graticule fitted within the eyepiece and visible in focus at the same time as the specimen.

Each candidate should have sole, uninterrupted, use of the microscope for at least 55 minutes.

Supervisors are advised to remind all candidates that **all** substances in the examination should be treated with caution. Pipette fillers and safety goggles should be used when necessary.

In accordance with the COSHH (Control of Substances Hazardous to Health) Regulation, operative in the UK, a hazard appraisal of the examination has been carried out.

The following codes are used where relevant.

C	=	corrosive substance
H	=	harmful or irritating substance
F	=	highly flammable substance
O	=	oxidising substance
T	=	toxic substance

Centres are reminded that they are **not** permitted to open any question paper envelopes before the examination. Centres are also referred to the Handbook for Centres 2007, and in particular Section 3.1.2 (c), Security of Question Papers and Examination Materials, as well as 3.3.11.1, Practical Examinations in Science Subjects.

Instructions to Supervisors

Each candidate must be provided with the following apparatus and materials.

To be supplied by the Centre

Question 1

Each candidate will require:

- (i) 20 cm³ of solution S1, labelled **S1**. This should be a 0.5 mol dm⁻³ glucose solution. It could be made by dissolving 9 g of glucose in 80 cm³ of water and making up to 100 cm³.
- (ii) A small volume (e.g. 10 cm³) of Benedict's solution in a suitable dispensing bottle, labelled **Benedict's solution**.
- (iii) A small volume (e.g. 10 cm³) of ethanol or industrial methylated spirit ('meths') in a suitable dispensing bottle, labelled **ethanol**.
- (iv) At least 20 cm³ of distilled water in a small dispensing bottle or a container with a pipette, labelled **distilled water**.
- (v) Test-tube rack containing two empty, unlabelled test-tubes, a large test-tube and a test-tube labelled **A**.
- (vi) Water-bath to perform Benedict's test, consisting of a Bunsen burner, tripod, gauze and beaker.
- (vii) A bung and glass or plastic delivery tube, as shown in Fig. 1.1, to fit the large test-tube in (v).

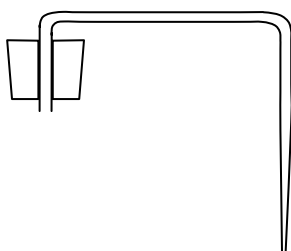

Fig. 1.1

- (viii) A beaker large enough to contain 150 cm³ of water and not overflow when the large test-tube is dipped in the water. This could be the same beaker as is used for the waterbath in (vi).
- (ix) Access to a tap dispensing water at, or below, room temperature.
- (x) 20 cm³ of yeast suspension S2, labelled **S2**. This should be made using a 1.0 mol dm⁻³ glucose solution. It could be made by dissolving 18 g of glucose in 80 cm³ of water. This can be made up several days before the examination. About half-an-hour before the examination, 1 g of dried yeast powder or granules should be thoroughly stirred into the glucose solution, and this should

be made up to 100 cm³ before the yeast starts to ferment and produce foam, which will make measurement of the volume difficult.

- (xi) Thermometer capable of measuring at least from 0 to 60 °C (e.g. a standard -10 to 110 °C laboratory thermometer would be suitable)
- (xii) A Bunsen burner. This could be the same burner as is used to heat the waterbath in (vi).

Question 2

Each candidate will require:

- (i) Specimen **S3**, a slice from a carrot, between 1 cm and 6 cm in diameter, and between 0.5 and 1 cm thick. The central stele should be clearly visible in the carrot used.
- (ii) Slide **S4**, a transverse section of *Ranunculus* root, suitably stained to show the central stele and starch grains in the parenchyma cells. (A suitable slide may be purchased from CIE, through the publications catalogue.)
- (iii) A microscope with:
 - Low-power objective lens, e.g. x10 (equal to 16 mm or $\frac{2}{3}$ ")
 - High-power objective lens, e.g. x40 (equal to 4 mm or $\frac{1}{6}$ ")
 - Eyepiece graticule fitted within the eyepiece and visible in focus at the same time as the specimen.
- (iv) Hand lens (e.g. x10)