

Nuclear physics (Chapter 26):

- In α decay, the nucleon number decreases by 4; proton number decreases by 2
- In β^- decay, the nucleon number is unchanged; the proton number increases by 1
- In β^+ decay, the nucleon number is unchanged; the proton number decreases by 1
- In γ emission, no change in nucleon and proton number

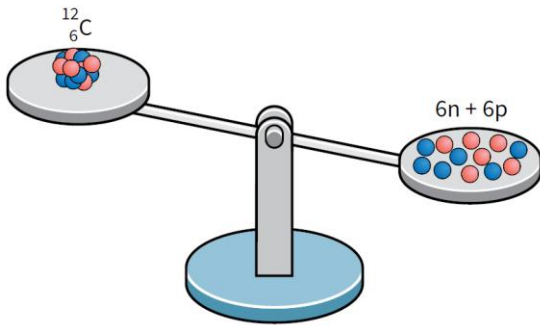

Figure 31.3 The mass of a nucleus is less than the total mass of its component protons and neutrons.

- Association between energy and mass:

$$E = mc^2$$

- Where c is $3.00 \times 10^8 \text{ m s}^{-1}$
- The mass of a system increases when energy is supplied to it; when energy is released from a system, mass decreases:

$$\Delta E = \Delta mc^2$$

Particle	Rest mass / 10^{-27} kg
^1_1p	1.672 623
^1_0n	1.674 929
$^{12}_6\text{C}$ nucleus	19.926 483

Table 31.1 Rest masses of some particles. It is worth noting that the mass of the neutron is slightly greater than that of the proton (roughly 0.1% greater).

- **Mass defect** of a nucleus is equal to the difference between the total mass of the individual, separate nucleons and the mass of the nucleus
 - E.g. particles in Fig. 31.3:

$$\begin{aligned} \text{mass before} &= (6 \times 1.672\,623 + 6 \times 1.674\,929) \times 10^{-27} \text{ kg} \\ &= 20.085\,312 \times 10^{-27} \text{ kg} \end{aligned}$$

$$\text{mass after} = 19.926\,483 \times 10^{-27} \text{ kg}$$

$$\begin{aligned} \text{mass difference } \Delta m &= (20.085\,312 - 19.926\,483) \times 10^{-27} \text{ kg} \\ &= 0.158\,829 \times 10^{-27} \text{ kg} \end{aligned}$$

- Loss in mass implies that energy is released:

$$\begin{aligned} E &= mc^2 \\ &= 0.158\,829 \times 10^{-27} \times (3.00 \times 10^8)^2 \\ &\approx 1.43 \times 10^{-11} \text{ J} \end{aligned}$$

- Atomic and nuclear masses often given in the **atomic mass unit (u)**
 - $1 \text{ u} = 1.6605 \times 10^{-27}$

Nuclide	Symbol	Mass / u
proton	${}^1_1\text{p}$	1.007 825
neutron	${}^1_0\text{n}$	1.008 665
helium-4	${}^4_2\text{He}$	4.002 602
carbon-12	${}^{12}_6\text{C}$	12.000 000
potassium-40	${}^{40}_{19}\text{K}$	39.963 998
uranium-235	${}^{235}_{92}\text{U}$	235.043 930

Table 31.3 Masses of some nuclides in atomic mass units. Some have been measured to several more decimal places than are shown here.

- **Mass excess** = mass (in u) – nucleon number
 - So the mass excess for U-235 is $235.043\ 930 - 235 = 0.043\ 930 \text{ u}$
- E.g. decay of a nucleus of uranium-238:

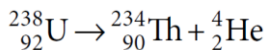

- Δm is equivalent to the energy released as K.E. of the products, where using accurate values:

$$\text{mass of } {}^{238}_{92}\text{U} \text{ nucleus} = 3.952\ 83 \times 10^{-25} \text{ kg}$$

$$\begin{aligned} \text{total mass of } {}^{234}_{90}\text{Th} \text{ nucleus and } \alpha\text{-particle } ({}^4_2\text{He}) \\ = 3.952\ 76 \times 10^{-25} \text{ kg} \end{aligned}$$

$$\begin{aligned} \text{change in mass } \Delta m &= (3.952\ 76 - 3.952\ 83) \times 10^{-25} \text{ kg} \\ &\approx -7.0 \times 10^{-30} \text{ kg} \end{aligned}$$

- Hence energy released in the decay:

$$\begin{aligned} \text{energy released} &\approx 7.0 \times 10^{-30} \times (3.0 \times 10^8)^2 \\ &\approx 6.3 \times 10^{-13} \text{ J} \end{aligned}$$

- **Binding energy:** the minimum energy needed to pull a nucleus apart into its separate nucleons
- To find the binding energy per nucleon for a nuclide:
 - Find mass defect for the nucleus.
 - Use Einstein's mass–energy equation, find the binding energy of the nucleus (mass defect $\times c^2$)
 - Divide the binding energy of the nucleus by the number of nucleons to calculate the binding energy per nucleon
- The greater the value of the binding energy per nucleon, the more tightly bound the nucleons that make up the nucleus

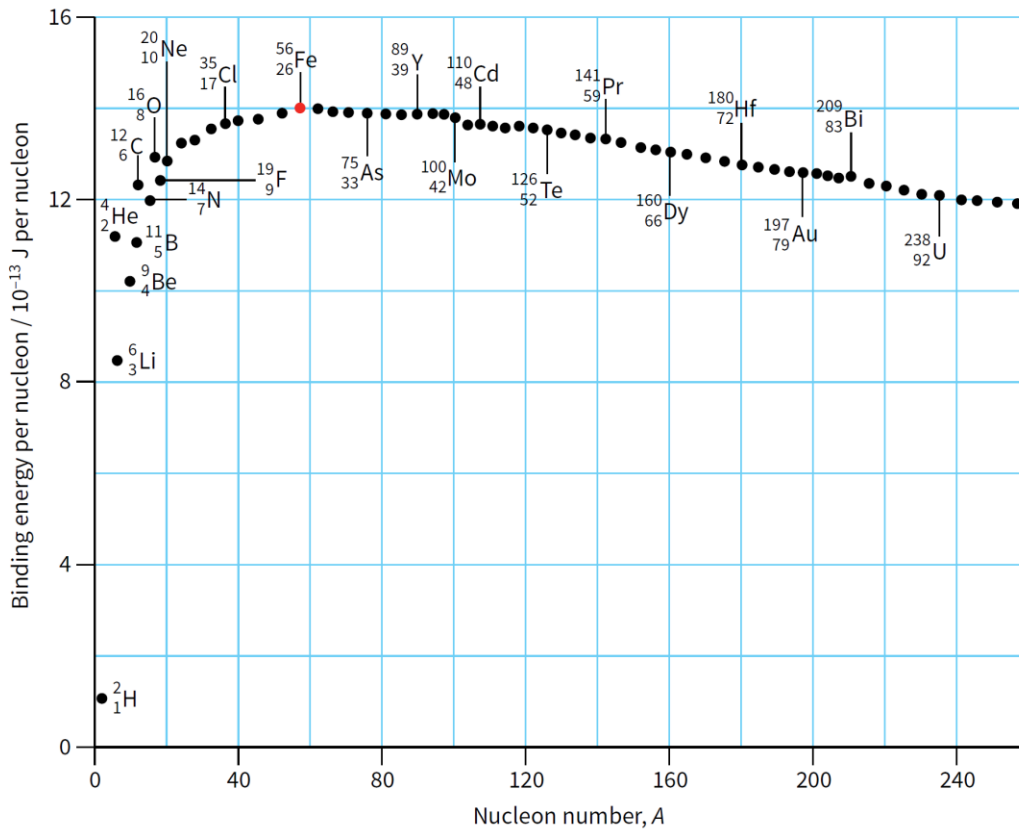

Figure 31.4 This graph shows the binding energy per nucleon for a number of nuclei. The nucleus becomes more stable as binding energy per nucleon increases.

Calculate the binding energy per nucleon for the nuclide ${}^{56}_{26}\text{Fe}$.

mass of neutron = 1.675×10^{-27} kg

mass of proton = 1.673×10^{-27} kg

mass of ${}^{56}_{26}\text{Fe}$ nucleus = 9.288×10^{-26} kg

Step 1 Determine the mass defect.

number of neutrons = $56 - 26 = 30$

mass defect

$$= (30 \times 1.675 \times 10^{-27} + 26 \times 1.673 \times 10^{-27}) - 9.288 \times 10^{-26}$$

$$= 8.680 \times 10^{-28} \text{ kg}$$

Step 2 Determine the binding energy of the nucleus.

$$\begin{aligned} \text{binding energy} &= \Delta mc^2 \\ &= 8.680 \times 10^{-28} \times (3.00 \times 10^8)^2 \\ &= 7.812 \times 10^{-11} \text{ J} \end{aligned}$$

Step 3 Determine the binding energy per nucleon.

$$\begin{aligned} \text{binding energy per nucleon} &= \frac{7.812 \times 10^{-11}}{56} \\ &\approx 14 \times 10^{-13} \text{ J} \end{aligned}$$

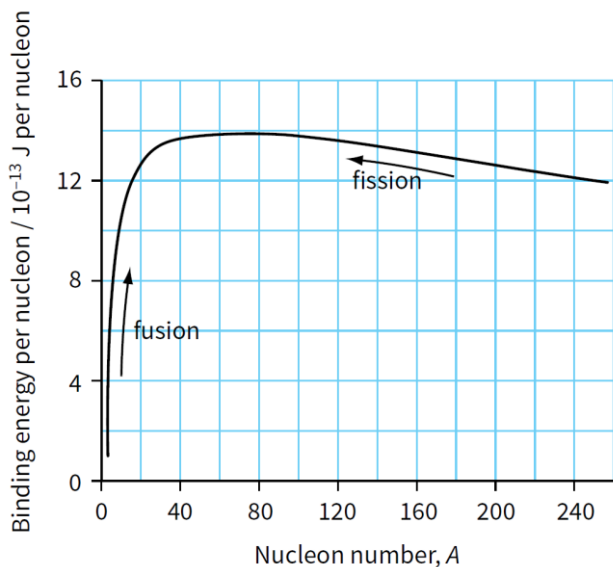

Figure 31.6 Both fusion and fission are processes that tend to increase the binding energy per nucleon of the particles involved.

- **Nuclear fission:** heavy / large nucleus splits into two nuclei of approximately equal masses
 - Binding energy of nucleus = $B_E \times A$
 - Binding energy of parent nucleus is less than the sum of the two binding energies fragments
- **Nuclear fusion:** process by which two very light nuclei join together to form a heavier nucleus
 - Binding energy of nucleus = $B_E \times A$
 - Binding energy of parent nuclei is less than the final binding energy nucleus of the product
- Graph of count rate against time, where the fluctuations on either side are caused by the randomness of the decay:

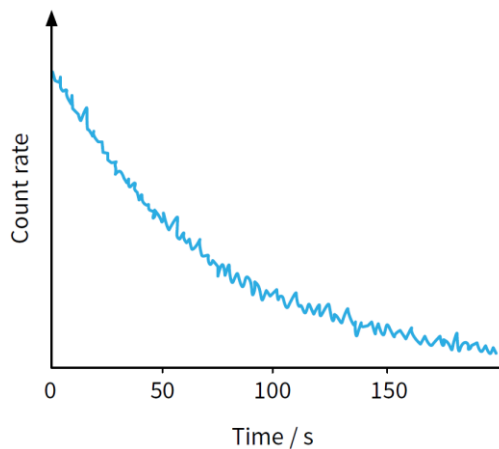

Figure 31.8 Count rate showing randomness of decay.

- Nuclear decay is **spontaneous** because:
 - The decay of a particular nucleus is not affected by the presence of other nuclei
 - The decay of nuclei cannot be affected by chemical reactions or external factors such as temperature and pressure
- Nuclear decay is **random** because:
 - Impossible to predict when a particular nucleus in a sample is going to decay
 - Each nucleus in the sample has the same chance of decaying per unit time
- Difference between the actual half-life value and calculated without any faulty equipments can be caused by:
 - Random nature of decay
 - Background radiation
 - Daughter product is also radioactive
- Difference between the activity of a sample might not be equal to the measured count rate due to:
 - Background count rate / radiation
 - Multiple possible counts for each decay
 - Radiation emitted in all directions
 - Dead-time of counter
 - Daughter product might also be unstable / emits radiation
 - Self-absorption of radiation in a sample or absorption in air

- **Decay constant (λ):** the probability that an individual nucleus will decay per unit time interval; unit: h^{-1} or s^{-1} or day^{-1} or year^{-1} , etc.
- The **activity A** of a radioactive sample is the rate at which nuclei decay or disintegrate; unit: Bq

$$A = \lambda N$$

- N is the number of undecayed nuclei present in the sample
- Activity can be thought of the number of α - or β - particles emitted from the source per unit time:

$$A = \frac{\Delta N}{\Delta t}$$

- N is the number of emissions (decays) in a small time interval of Δt

A radioactive source emits β -particles. It has an activity of 2.8×10^7 Bq. Estimate the number of β -particles emitted in a time interval of 2.0 minutes. State one assumption made.

Step 1 Write down the given quantities in SI units.

$$A = 2.8 \times 10^7 \text{ Bq} \quad \Delta t = 120 \text{ s}$$

Step 2 Determine the number of β -particles emitted.

$$A = \frac{\Delta N}{\Delta t} \quad \Delta N = A \Delta t$$

$$\Delta N = 2.8 \times 10^7 \times 120 = 3.36 \times 10^9 \approx 3.4 \times 10^9$$

We have assumed that the activity remains constant over a period of 2.0 minutes.

A sample consists of 1000 undecayed nuclei of a nuclide whose decay constant is 0.20 s^{-1} . Determine the initial activity of the sample. Estimate the activity of the sample after 1.0 s.

Step 1 Since activity $A = -\lambda N$, we have:

$$A = 0.20 \times 1000 = 200 \text{ s}^{-1} = 200 \text{ Bq}$$

Step 2 After 1.0 s, we might expect 800 nuclei to remain undecayed.

The activity of the sample would then be:

$$A = 0.2 \times 800 = 160 \text{ s}^{-1} = 160 \text{ Bq}$$

(In fact, it would be slightly higher than this. Since the rate of decay decreases with time all the time, less than 200 nuclei would decay during the first second.)

- **Count rate:** the number of particles (beta or alpha) or gamma-ray photons detected per unit time by a Geiger-Muller tube, where it is always a fraction of the sample's activity
- Radioactive decay follows an exponential decay pattern:

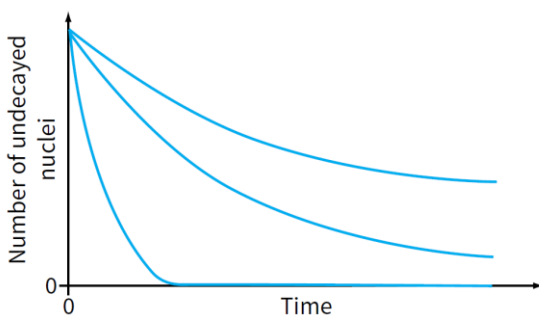

Figure 31.9 Some radioactive materials decay faster than others.

- The **half-life $t_{1/2}$** of a radioisotope is the mean time taken for half of the active nuclei in a sample to decay

- Activity is proportional to the number of undecayed nuclei ($A \propto N$); hence in a time equal to one half-life, the activity of the sample will also halved

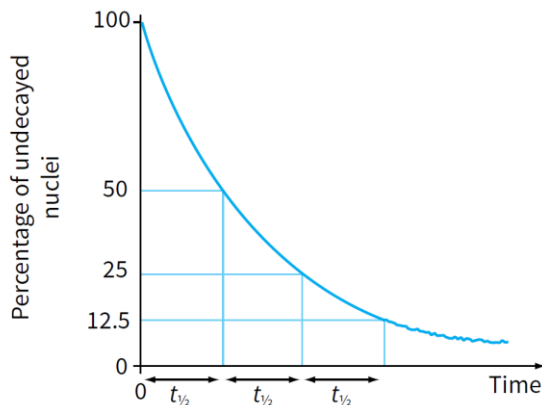

Figure 31.10 All radioactive decay graphs have the same characteristic shape.

- The activity A of a sample is proportional to the number of undecayed nuclei given by:

$$A = A_0 e^{(-\lambda t)}$$

- Starting with N_0 undecayed nuclei, then the number N that remain undecayed after time t is given by:

$$N = N_0 e^{(-\lambda t)}$$

- Count rate is a fraction of activity, hence decreases exponentially with time too, given by:

$$R = R_0 e^{(-\lambda t)}$$

- In a time of one half-life $t_{1/2}$, the number of undecayed nuclei is halved giving:

$$N = N_0 e^{(-\lambda t)}$$

becomes:

$$\frac{N}{N_0} = e^{(-\lambda t_{1/2})} = \frac{1}{2}$$

Therefore:

$$e^{(\lambda t_{1/2})} = 2$$

$$\lambda t_{1/2} = \ln 2 \approx 0.693$$

- The half-life and decay constant are inversely proportional to each other:

$$\lambda = \frac{0.693}{t_{1/2}}$$

Electronic sensors (Chapter 19 & 20):



Figure 25.2 Block diagram of an electronic sensor.

- An electronic sensor consists of a sensing device and a circuit that provides an output that can be registered as a voltage

- The sensing device (transducer – changes energy from one form into another) changes its property when there is a change in physical quantity, such as temperature (thermistor) and light intensity (light-dependent resistor); changes in resistance causes the processor to produce an output voltage that drives the output device (switching it on)
- A light-dependent resistor (LDR) is made of a high-resistance semiconductor; if light of high enough frequency falls on it, the resistance will be reduced

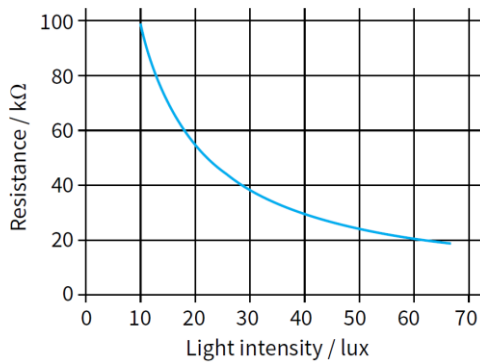

Figure 25.4 Resistance plotted against light intensity for an LDR.

- LDR is placed in series with a fixed resistor to generate the change in voltage, forming a potential divider

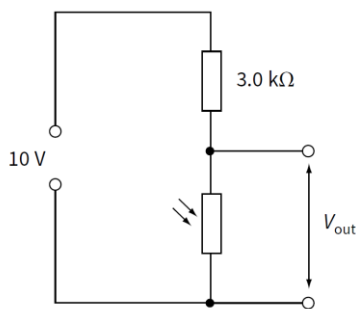

Figure 25.5 An LDR used in a sensor.

- The thermistors (negative temperature coefficient thermistors) where as temperature rises, the resistance of the thermistor falls; used the same way as the LDR

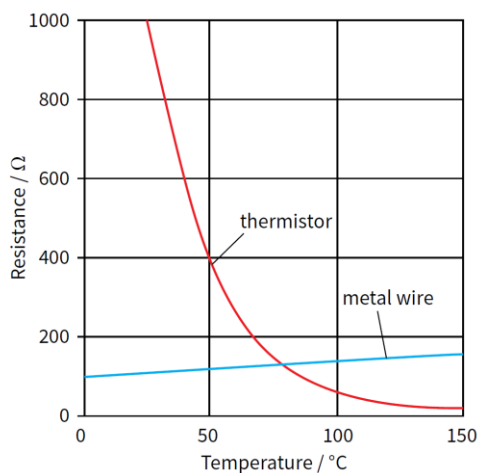

Figure 25.6 Variation of resistance with temperature.

- The metal-wire strain gauge uses the change in resistance of a metal wire as its length and cross-sectional area change; when stretched, wire becomes narrower and longer – increase resistance; when compressed, wire becomes shorter and wider, decreases resistance

- A metal-wire strain gauge consists of a thin wire placed between thin sheets of plastic; zigzags up and down its plastic base so that the length of wire used is longer than the actual strain gauge

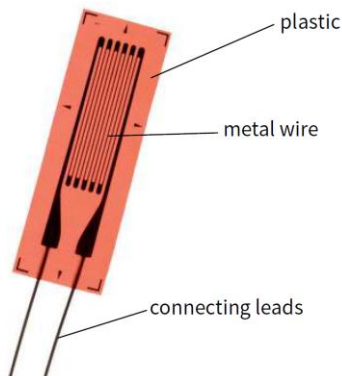

Figure 25.7 A metal-wire strain gauge.

- The wire of length L , cross-sectional area A and resistivity ρ has a resistance R given by:

$$R = \frac{\rho L}{A}$$

- If the wire increases in length by a small amount δL and the cross-sectional area A is unchanged, then the resistance of the wire increase by δR :

$$R + \delta R = \frac{\rho(L + \delta L)}{A}$$

- Subtracting the two equations give:

$$\delta R = \frac{\rho \delta L}{A}$$

- Expression divided by $R = \frac{\rho L}{A}$:

$$\frac{\delta R}{R} = \frac{\delta L}{L}$$

- Hence the change in resistance is directly proportional to the increase in length (extension), $\delta R \propto \delta L$
- Some crystals such as quartz crystals produce an electric field when a force is applied causing changes in the shape of the crystal, known as the **piezo-electric effect**
 - A piezo-electric crystal consists of positive and negative ions in a regular arrangement, hence when it is stressed, a small voltage is produced between the faces of the crystal, hence it acts as a transducer
 - In microphones, the crystal is made into a thin sheet with metal connections on opposite sides; when a sound wave hits one side of the sheet, the compressions and rarefactions cause the pressure to increase and decrease, hence the crystal

changes shape in response to these pressure changes and a small voltage is induced across the connections

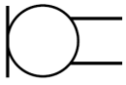

Figure 25.3 The symbol for a microphone.

- Acoustic guitars and other instruments often use a piezo-electric transducer to produce an electrical output; the microphone is stuck to the body of the guitar and the electrical output can be amplified and played back through loudspeakers

Electronics (Chapter 21):

- The goal of an amplifier is to produce a constant amplification or **gain** (all frequencies), hence **operational amplifier (op-amp)** has a very high gain and then provide an external circuit which reduces the gain but ensures that the overall gain is the same for signals of a greater range of frequencies

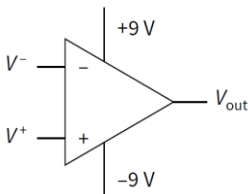

Figure 25.15 An operational amplifier and its symbol.

- The op-amp has two inputs:
 - Inverting input, marked (-)
 - Non-inverting input, marked (+)
- The function of op-amp is to use the potential difference between the two inputs (potential at inverting input (V^-) and potential at non-inverting input (V^+) to produce as large an output voltage V_{out} as possible
- The open-loop voltage gain G_0 is given by:

$$G_0 = \frac{\text{output voltage}}{\text{input voltage}}$$

- Hence for the op-amp in Fig 25.15, the open-loop voltage gain is given by:

$$G_0 = \frac{V_{out}}{(V^+ - V^-)}$$

- It is called an open-loop because there is no loop of resistors or other components linking the output back to the input – it is just the operational amplifier alone
- Unlike a transformer, an op-amp's output power is much greater than its input power; achieved by having two power supplies (e.g. +9 V and -9 V connections), and a zero volt line, or earth (all voltages are measured relative to this potential); one power supply will be between the +9 V and 0 V line and the other between -9 V connection and the 0 V line

- The actual voltage used for the power supplies can vary in different circuits (providing the power for the op-amp); the positive and negative supply voltages are equal in magnitude and may be written as $+V_s$ and $-V_s$, and are often left out for clarity
- The largest voltage an op-amp can produce is a value close to the supply voltage, e.g. between -9 V and $+9\text{ V}$, and when it reaches one of these values, it is saturated
- The main properties of an ideal op-amp:
 - Infinite open-loop gain
 - Signals of a wide range of frequencies have equal gain before the feedback is applied
 - Infinite input resistance / impedance
 - No current is drawn from the supply, there are no 'lost volts' and the input voltage to the op-amp is large as possible; the resistance for an alternating voltage is known as impedance and no current passes into the input terminals
 - Zero output resistance / impedance
 - No 'lost volts' when current is supplied by the op-amp
 - Infinite bandwidth
 - The bandwidth of an op-amp is the range of frequencies that are amplified by the same amount; an ideal op-amp will amplify signals of all frequencies, and therefore has an infinite bandwidth
 - Infinite slew rate
 - An ideal op-amp changes its output instantaneously as the input is changed; an infinite slew rate means there is no time delay
- The op-amp as a comparator (to compare two potentials / voltages output depending upon which is greater):

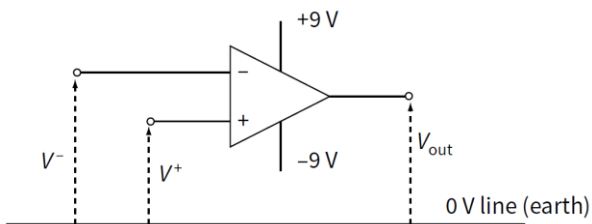

Figure 25.16 An op-amp used as a comparator.

- The output voltage is given by:

$$V_{\text{out}} = G_0 \times (V^+ - V^-)$$

- Suppose that $G_0 = 10^5$ and $V^+ = 0.15\text{ V}$ and $V^- = 0.10\text{ V}$

$$V_{\text{out}} = 10^5 \times (0.15 - 0.10) = 5000\text{ V}$$

- The op-amp is therefore saturated and V_{out} will be close to one of the power supply voltages, in this case $+9\text{ V}$:
 - If V^+ is slightly greater in magnitude than V^- , then V_{out} will have a magnitude equal to the positive power supply voltage

- If V^+ is slightly smaller in magnitude than V^- , then V_{out} will have a magnitude equal to the negative power supply voltage
- The op-amp compares V^+ and V^- and tells which one is larger

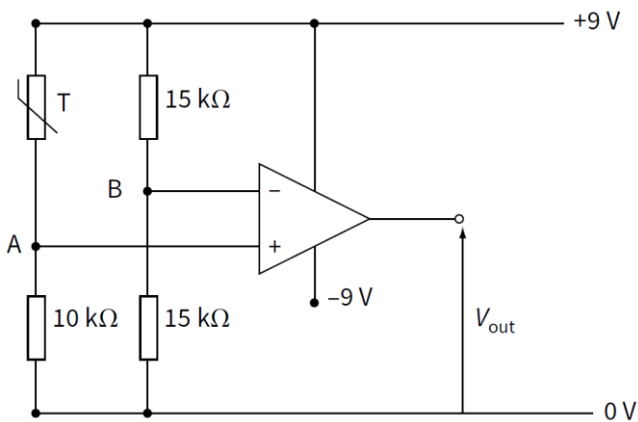

Figure 25.17 An op-amp used as a comparator to monitor temperature.

- A comparator circuit can be used to compare two temperatures of two light levels, where Fig 25.17 shows a circuit used to give a warning when the temperature sensed by thermistor T becomes smaller than a set-value
- The positive power supply to the op-amp is also used to supply voltage and current to the thermistor T and a 10 kΩ connected as a potential divider; another potential divider circuit connected to the inverting input of the op-amp

For the circuit shown in Figure 25.17, the resistance of the thermistor T is 8 kΩ at a temperature of 15 °C. What are V^- and V^+ , the potentials at the inverting and non-inverting inputs? And what happens when the temperature falls so that the resistance of T rises above 10 kΩ?

Step 1 V^- and V^+ can be found by using the potential divider formula to find the potentials at points A and B. The potential at A is the p.d. across the 10 kΩ resistor. So:

$$\text{potential at A} = 9 \times \frac{10}{18} = 5.0\text{V}$$

The potential at B is easier to find, as the two 15 kΩ resistors share the 9V equally.

$$\text{potential at B} = \frac{9}{2} = 4.5\text{V}$$

The op-amp acts as a comparator and, since V^+ is larger than V^- , the output will be the highest voltage that the op-amp can produce, in this case +9V.

Step 2 The thermistor T is a negative temperature coefficient thermistor and so its resistance rises sharply and eventually becomes larger than 10 kΩ. Suppose it becomes 12 kΩ. Then:

$$\text{potential at A} = 9 \times \frac{10}{22} = 4.1\text{V}$$

Now V^+ is smaller than V^- and the op-amp output voltage is the lowest it can provide, near the negative supply voltage, in this case -9V.

This switch from +9V to -9V is quite sudden because of the large open-loop voltage gain. The value of the temperature when the output voltage switches from +9V to -9V can be altered by adjusting the resistance of the resistor in series with the thermistor.

- Effects of negative feedback on the gain of an amplifier incorporating an op-amp:
 - Reduced gain
 - Increased stability

➤ Greater bandwidth / less distortion

- Electrical feedback:

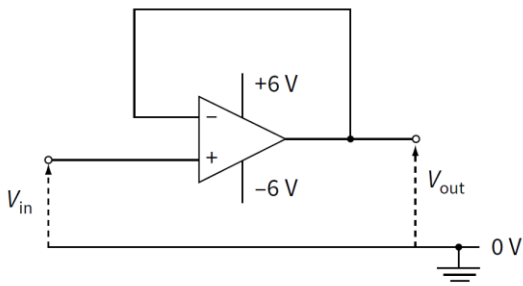

Figure 25.19 An op-amp with the output connected to the inverting input.

- The potential V at the inverting input is always the same as the V_{out} , as they are connected by feedback loop
- Assume that the open-loop voltage gain is infinite; the op-amp is not saturated
- As V_{out} is fed back to V , the value of V increases and this reduces the difference between V and V^+ , hence the difference becomes zero again and $V_{in} = V_{out}$

We know that $V_{out} = G_0 \times (V^+ - V^-)$, where G_0 is the open-loop voltage gain. Since $V_{out} = V^-$ and $V_{in} = V^+$ we have:

$$V_{out} = G_0(V_{in} - V_{out})$$

$$V_{out}(1 + G_0) = G_0 V_{in}$$

The closed-loop gain G is given by:

$$G = \frac{V_{out}}{V_{in}} = \frac{G_0}{(1 + G_0)}$$

- Because G_0 is very high ($\sim 10^5$), there is little difference between G_0 and $(G_0 + 1)$, so the closed-loop gain is very close to 1, since the input voltage was +0.1 V the output voltage also +0.1 V, as long as the output voltage is smaller than the supply voltage (e.g. as long as V_{out} is between -6 V and +6 V)
- The inverting amplifier:
 - Uses negative feedback
 - The non-inverting input is connected to the 0 V line
 - Part of the output voltage is connected to the inverting input
 - The input voltage is connected to the inverting input

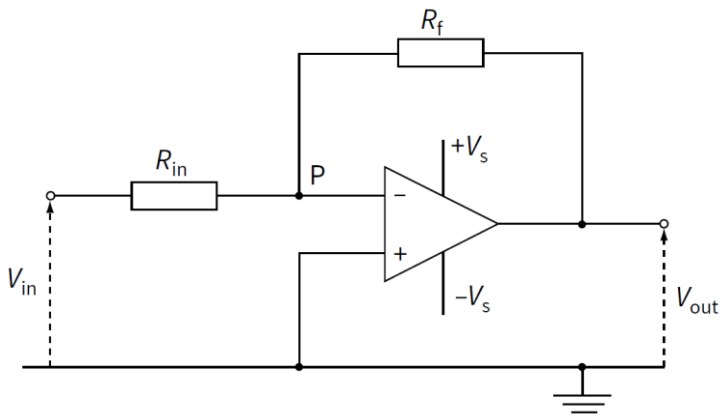

Figure 25.20 An inverting amplifier.

- Virtual earth approximation:
 - Op-amp has very large open-loop voltage gain
 - Op-amp saturates if $V^+ \neq V^-$
 - V^+ is at earth potential so V^- or P must be at earth
- If the current in input resistor R_{in} is I_{in} and the current in the feedback resistor R_f is I_f , then because point P is at 0 V:

$$I_{in} = \frac{V_{in}}{R_{in}} \quad \text{and} \quad I_f = \frac{V_{out}}{R_f}$$

- The input resistance of the op-amp is very high, so virtually no current enters or leaves the inverting input, hence $I_{in} = I_f$
- The output voltage has an opposite sign to that of the input voltage:

$$I_f = -I_{in} \quad \text{and} \quad \frac{V_{out}}{R_f} = -\frac{V_{in}}{R_{in}}$$

- Hence the gain of the inverting amplifier given by:

$$G = \frac{V_{out}}{V_{in}} = -\frac{R_f}{R_{in}}$$

- As long as the op-amp is not saturated, the p.d. between V^+ and V^- is almost zero, hence $V^+ = V^-$
- The non-inverting amplifier:
 - The input voltage is applied to the non-inverting input
 - Part of the output voltage is fed back to the inverting input

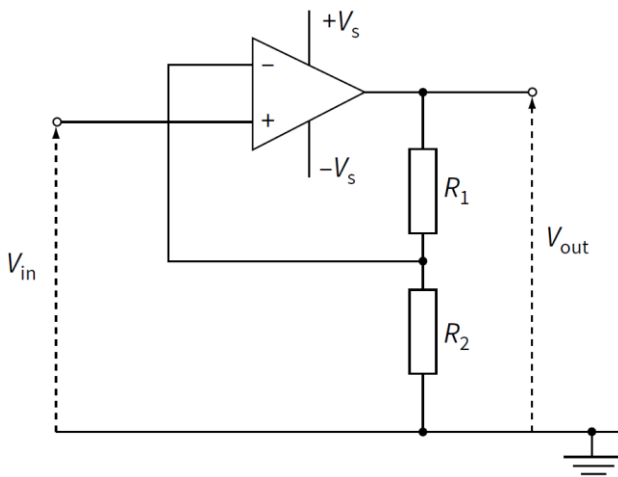

Figure 25.21 A non-inverting amplifier.

- As long as the op-amp is not saturated, the p.d. between V^+ and V^- is almost zero, hence $V^+ = V^-$
- Since the non-inverting input is connected to the input voltage, $V^+ = V^- = V_{in}$
- The two resistors (R_1 and R_2) forms a potential divider
- The total voltage across R_1 and R_2 is V_{out} and the voltage across R_2 is V_{in}
- The current in the two resistors can be written as:

$$\frac{V_{out}}{(R_1 + R_2)} = \frac{V_{in}}{R_2}$$

- The gain is calculated from:

$$G = \frac{V_{out}}{V_{in}} = \frac{(R_1 + R_2)}{R_2} = 1 + \left(\frac{R_1}{R_2}\right)$$

- Hence for a non-inverting amplifier the gain is given by:

$$G = 1 + \left(\frac{R_1}{R_2}\right)$$

- Input and output voltage has the same sign
- An output device may be required to monitor the output of an op-amp circuit:
- ❖ The relay:
 - A typical op-amp can provide a maximum output current of 25 mA; maximum output voltage of 15 V
 - To switch on larger currents and voltages op-amp is connected to relay

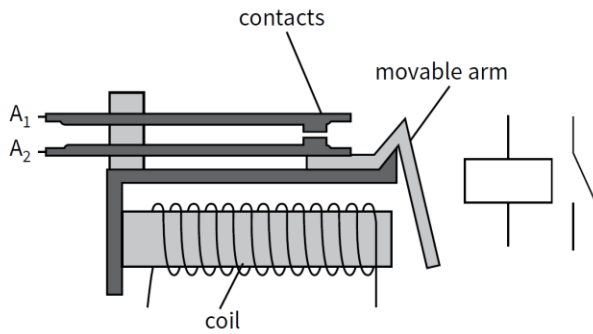

Figure 25.22 A relay and its circuit symbol.

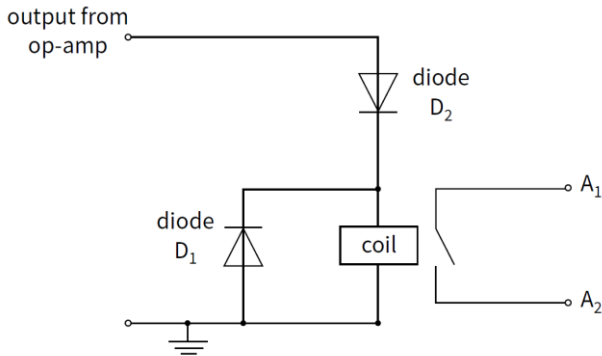

Figure 25.23 The output of an op-amp connected to a relay.

- Relay is just an electromagnetic switch operated by a small current in the coil
 - There are two separate circuits: one to the coil and one involving the contacts A_1 and A_2 ; when a small current passes through the coil of the relay in Fig 25.22, the iron core attracts the movable arm and the contacts connected to contacts A_1 and A_2 close, completing the circuit
 - A reverse-biased diode, D_1 , is placed across the relay coil; when the op-amp switches off, the induced voltage in the coil causes the bottom of the coil to be more positive than the top of the coil, hence diode D_1 is able to pass current round the coil without damaging the op-amp
 - Diode D_2 ensures that current can only flow from op-amp when the op-amp output is positive, hence the relay contacts are closed only when the output is positive
- ❖ The light-emitting diode (LED):
- LED only requires a current of 20 mA to produce a light output
 - LED starts to conduct when the voltage across it is greater than about 2 V
 - The value of the resistance of the series resistor R can be calculated, e.g. a current is 20 mA and max. voltage output from op-amp is 12 V, then there will be just 2 V across the LED and $12 - 2 = 10$ V across the series resistor R ; the series resistor required is:

$$R = \frac{10}{0.02} = 500 \Omega$$

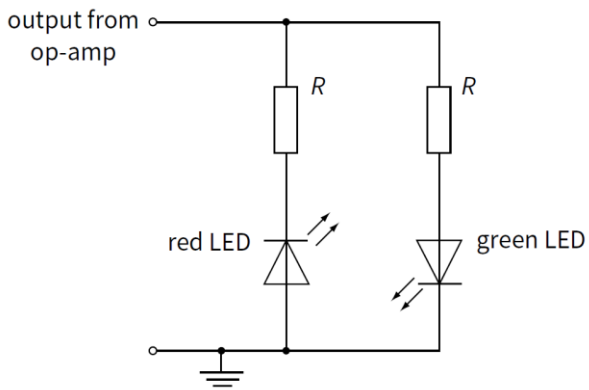

Figure 25.24 LEDs connected to the output of an op-amp.

- When the output of the op-amp is positive relative to earth, the green LED lights
 - When the output of the op-amp is negative relative to earth, the red LED lights
- ❖ The calibrated meter:

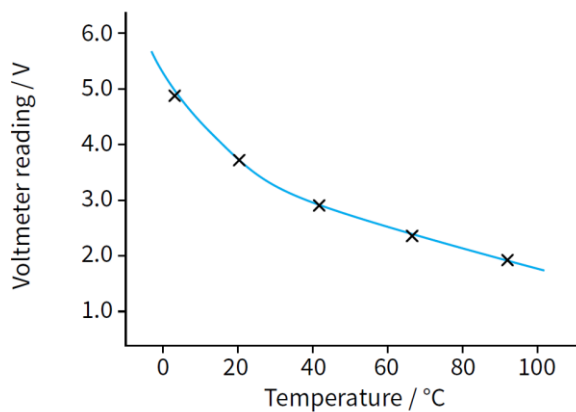

Figure 25.25 A calibration curve relates the output voltage of an op-amp to the variable it is being used to measure.

- Output voltage of op-amp is unlikely to be proportional to the physical quantity being measured, e.g. temperature
- With a digital voltmeter, calibration is needed by placing the temperature sensor and a thermometer in a water bath at a number of different temperatures; the calibration curve is used to change any voltmeter reading into a value for the physical quantity
- With an analogue voltmeter, calibration done in the same way, but result will be cause a change in the linearity of the scale