

Centre Number

Candidate Number

Name

UNIVERSITY OF CAMBRIDGE INTERNATIONAL EXAMINATIONS
International General Certificate of Secondary Education

DESIGN AND TECHNOLOGY**0445/04**

Paper 4 Technology

May/June 2006

1 hour

Candidates answer on the Question Paper.
No Additional Materials are required.

To be taken together with Paper 1 in one session of 2 hours 45 minutes.

READ THESE INSTRUCTIONS FIRST

Write your Centre number, candidate number and name on all the work you hand in.
Write in dark blue or black pen in the spaces provided on the Question Paper.
You may use a soft pencil for any diagrams, graphs or rough working.
Do not use staples, paper clips, highlighters, glue or correction fluid.

Answer any **two** questions.

You may use a calculator.

At the end of the examination, fasten all your work securely together.

The number of marks is given in brackets [] at the end of each question or part question.

FOR EXAMINER'S USE

1	
2	
3	
4	
TOTAL	

This document consists of **16** printed pages.



- 1 Fig. 1 shows a student's design for an electronic game.

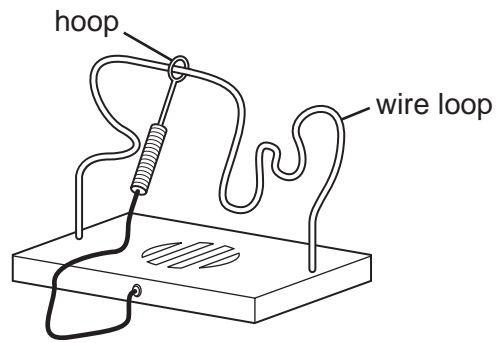

Fig. 1

- (a) Draw a simple circuit using a battery and buzzer that would make a sound when the hoop touches the wire loop.

[4]

- (b) After testing the simple circuit it is decided to use a 555 timer circuit as shown in Fig. 2.

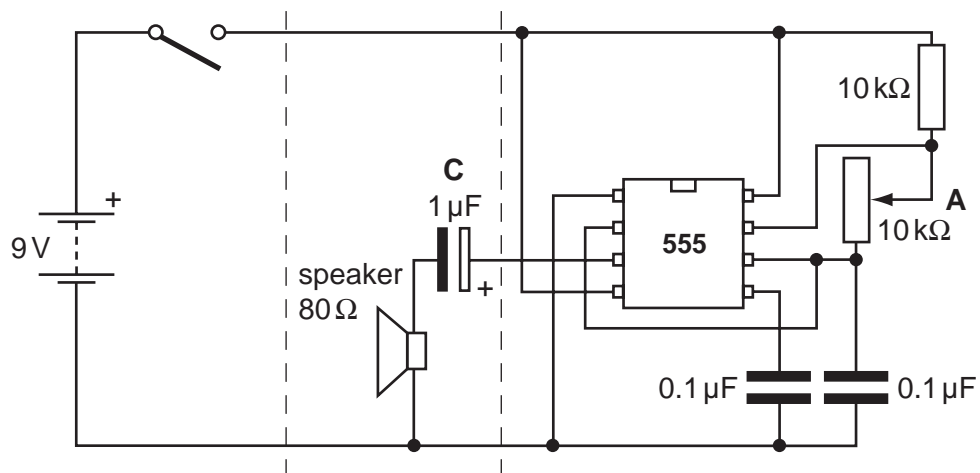

Fig. 2

(i) Explain **two** benefits of using the 555 circuit.

.....

.....

.....

.....

.....

..... [4]

(ii) Explain the purpose of component **A**.

.....

.....

..... [3]

(iii) Label the 555 IC in Fig. 2 to show the pin numbers. [3]

(iv) Name the type of capacitor shown as **C**. [1]

..... [1]

(c) For the circuit shown in Fig. 2 complete the block diagram below.

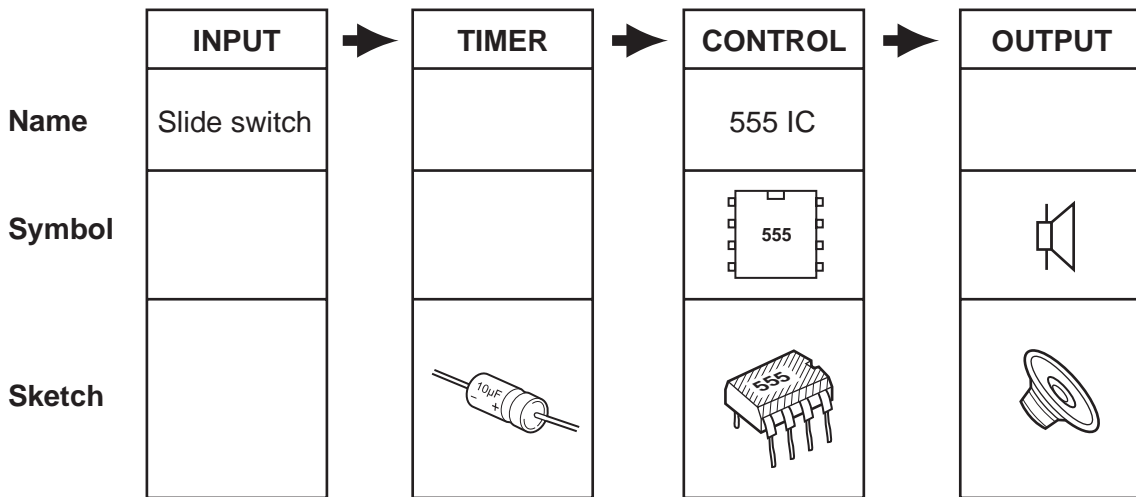

[5]

(d) Fig. 3 shows a chart for selecting values of resistance and capacitance for a time delay circuit.

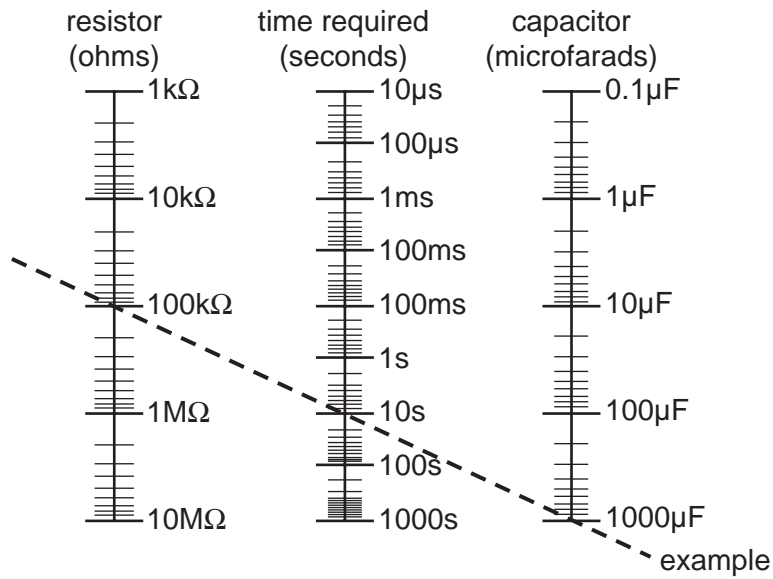

Fig. 3

(i) State the values of resistance (R) and capacitance (C) for the example time delay of 10 seconds.

R C [2]

(ii) Use the chart to find the time delay created by combining a resistance of 10 MΩ with a capacitance of 100 μF.

..... [1]

(iii) You could calculate the value of a time delay using a standard formula.

State the formula used for calculating a time delay.

.....

 [2]

(e) In practice it is difficult to predict accurately the time delay value.

(i) Explain **two** reasons why this is so.

.....
.....
.....
.....
.....
..... [4]

(ii) Identify a component in the circuit shown in Fig. 2 that can help to adjust the time delay to bring it nearer to the required value.

..... [1]

2 Fig. 4 shows part of a student's design for a mechanical toy.

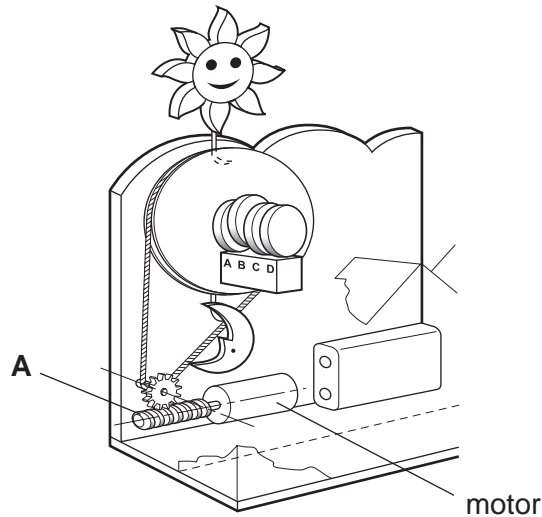

Fig. 4

(a) Identify **three** different mechanisms in the mechanical toy.

.....

.....

..... [3]

(b) Describe, using notes and sketches, what happens for one revolution of the motor. Show clearly all motion conversions.

[5]

(c) (i) Name **one** factor that affects the efficiency of the toy's mechanisms.

..... [1]

(ii) Explain **one** way of overcoming this factor.

.....

.....

..... [2]

(d) (i) Name **one** material that could be used to make mechanism **A**.

..... [1]

(ii) Explain why this material is suitable for this part.

.....
.....
.....
.....
.....
..... [3]

(e) Mechanism **A** changes the direction of motion through 90°.

(i) Name **two** other mechanisms that change the direction of motion through 90°.

.....
..... [2]

(ii) Give a practical application for each mechanism named in (e)(i).

1 [1]

2 [1]

(iii) Sketch and label **one** of your chosen mechanisms named in part (e)(ii). Show clearly its parts and the direction of input and output motion.

[3]

(f) Fig. 5 shows a gear mechanism.

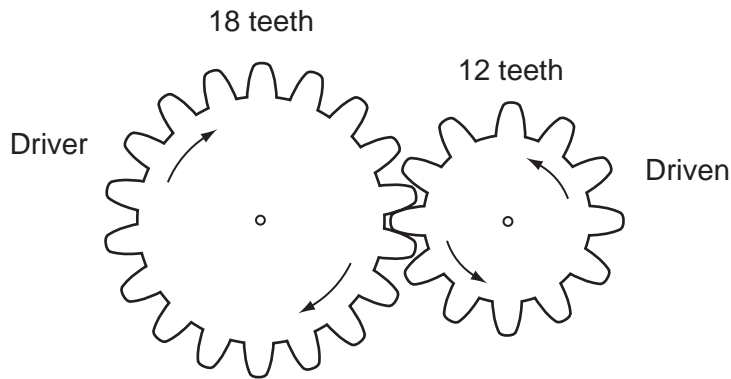

Fig. 5

(i) Calculate the gear ratio for the gear mechanism shown in Fig. 5.

.....

 [3]

(ii) The input speed is 200 rpm.

Calculate the output speed.

.....

 [3]

(iii) Show how the gear system can be modified to ensure that the output motion direction is the same as the input direction.

[2]

3 Fig. 6 shows an experiment on loading of beams.

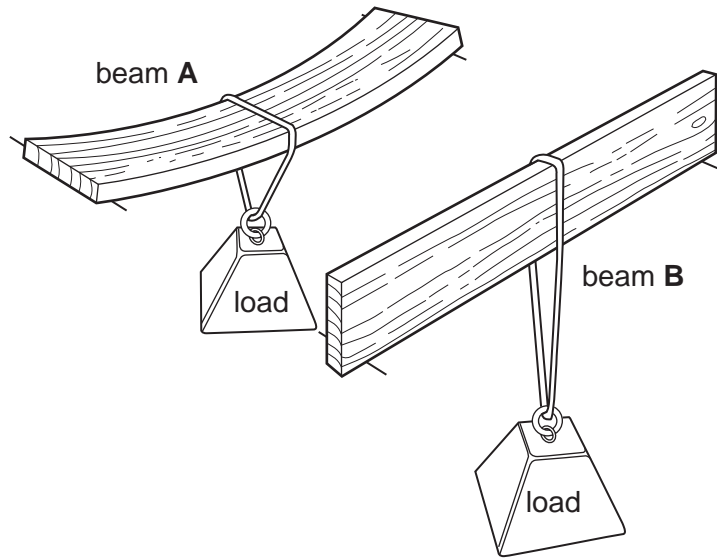

Fig. 6

(a) Explain why beam B does not bend as much as beam A.

.....

.....

.....

..... [3]

(b) For beam A draw a diagram showing the following features:

- tensile forces,
- compressive forces,
- neutral axis.

[4]

(c) Determine the reactions at the supports at each end of the beam **A** for a load of 150 N.

.....
.....
.....
..... [3]

(d) Fig. 7 shows a variety of structural sections.

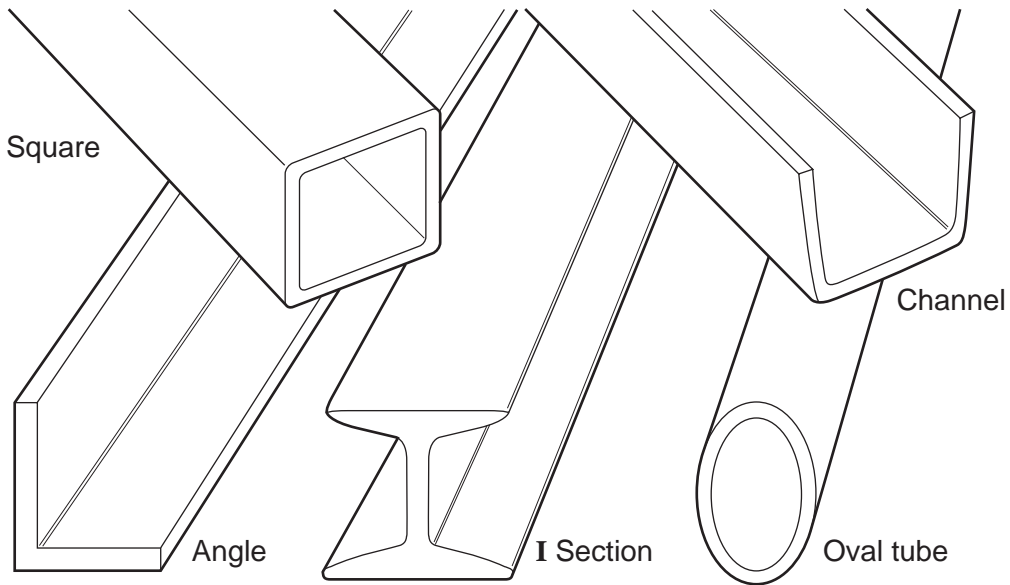

Fig. 7

(i) Explain why these sections are advantageous compared to solid bar material.

.....
.....
.....
..... [3]

(ii) Explain why the I Section beam is shaped in this way.

.....
.....
.....
..... [3]

(iii) Give **two** practical applications for any of the beams shown.

1 Beam Section:

Application: [1]

2 Beam Section:

Application: [1]

(iv) The beams are made from mild steel. Describe, using notes and sketches, **one** method of joining angle section beams to form a 90° corner.

[3]

(e) Fig. 8 shows a framework for a simple roof truss.

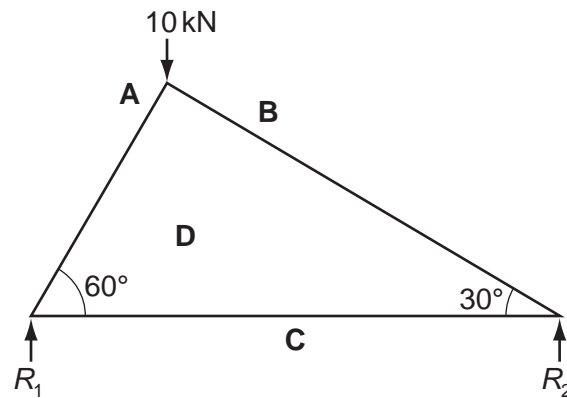

Fig. 8

(i) Use graphical means to determine the reactions R_1 and R_2 and find the value of each internal force in each member.

[7]

(ii) Label Fig. 8 to show those members in tension and those in compression.

[2]

4 Fig. 9 shows the firing mechanism for a pinball game.

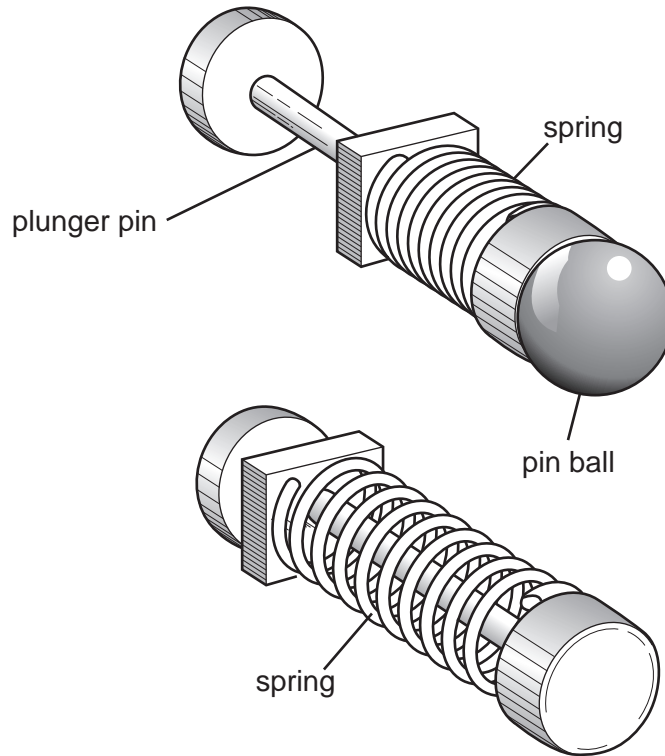

Fig. 9

(a) Explain how the firing mechanism works in terms of energy conversions.

.....

.....

.....

..... [3]

(b) Describe, using notes and sketches, how you could measure the forces in the spring.

[4]

(c) The spring is made from an elastic material.

Explain the term elastic.

.....
.....
.....
..... [3]

(d) The spring could be replaced by an electrical solenoid.

Sketch a solenoid. Label clearly the following features:

- coil;
- core;
- electrical connections.

[4]

(e) Draw and label a circuit that would control the solenoid so that it would fire a ball when a light sensor was covered over momentarily.

[6]

(f) Fig. 10 shows the pinball game.

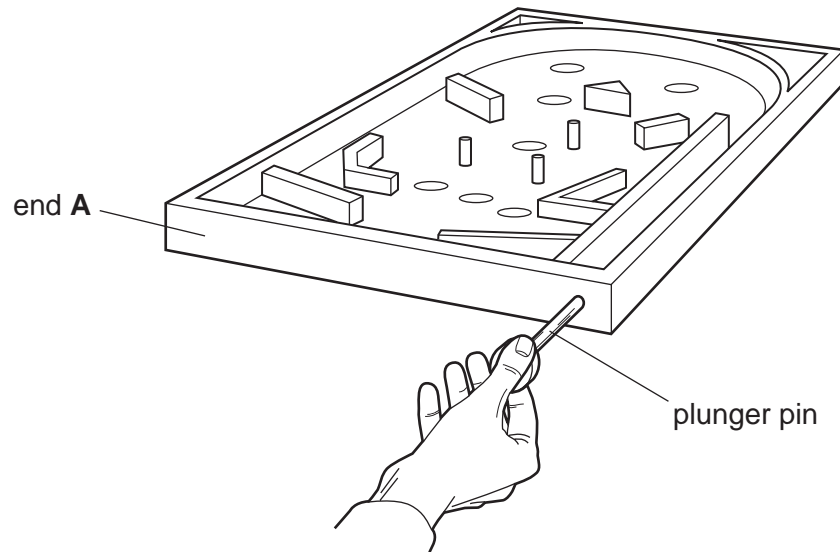

Fig. 10

(i) During testing it is found that end **A** deflects.

Use sketches and notes to show **one** accurate method for measuring the deflection of end **A**.

[4]

(ii) It is also found that the length of the plunger pin extends by 0.01 mm.

Its original length is 80 mm. Determine the strain on the pin.

.....
..... [3]

(iii) The plunger pin experiences dynamic loading.

Explain, using notes and sketches, what is meant by dynamic loading.

[3]

Permission to reproduce items where third-party owned material protected by copyright is included has been sought and cleared where possible. Every reasonable effort has been made by the publisher (UCLES) to trace copyright holders, but if any items requiring clearance have unwittingly been included, the publisher will be pleased to make amends at the earliest possible opportunity.

University of Cambridge International Examinations is part of the University of Cambridge Local Examinations Syndicate (UCLES), which is itself a department of the University of Cambridge.