

1 As part of a special promotion, a manufacturing company called **HEXAGON TUBE** is to give away hats made from thin card. The outline of the development of the hat is shown to the right.

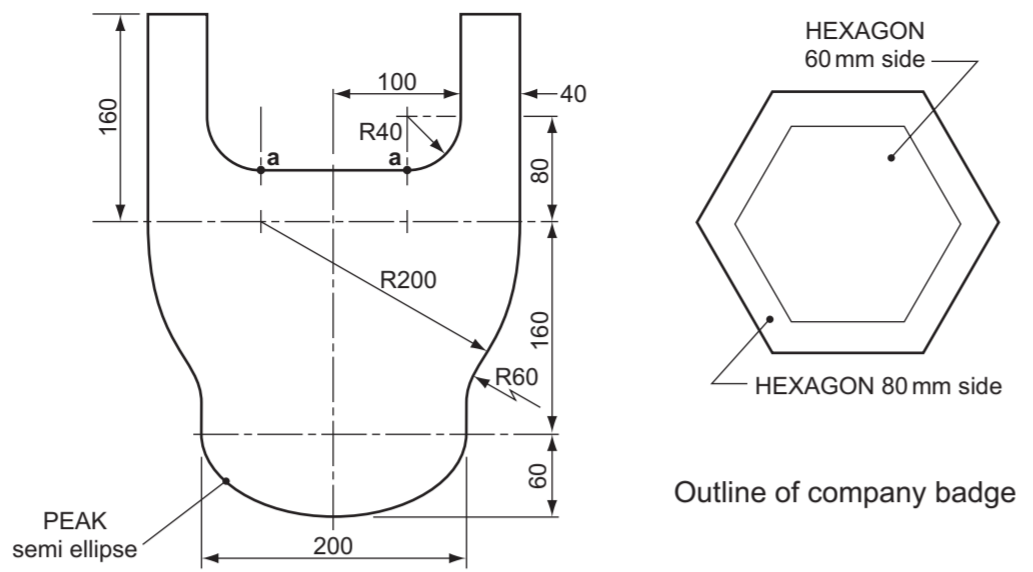

(a) On the centreline below, draw the development of the hat to a scale of 1:2. The start line **a-a** has been drawn for you. All construction work should be clearly shown. [15]

(b) The hat is to have the company badge printed on the top of the peak. Using the sizes from the outline of the company badge shown to the right:

- (i) draw the company badge on the development you have drawn below; [6]
- (ii) draw the letters **TUBE** in a suitable style on the inner hexagon of the company badge. [6]

(c) The hats need to fit adults and children. Draw on the development a method of fastening the two 40 mm wide strips together at two different length settings. [3]

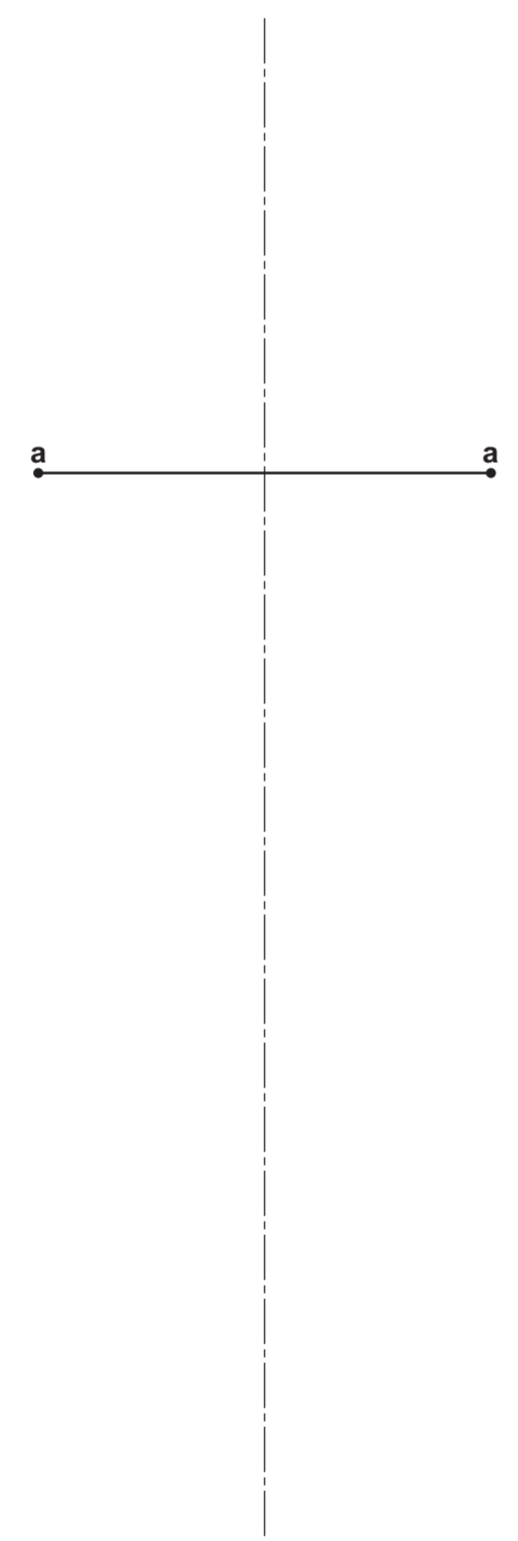

Scale 1:2 development

2 A vehicle hire company called **U-DRIVE** is to produce an advertising postcard to send to potential customers. The postcard is to be folded by the customer to make a desk tidy. The outline of the postcard is drawn below.

(a) Accurately divide the long side of the postcard into three equal parts so that, when folded, the postcard will have three faces as shown in the pictorial view. [3]

(b) (i) To a scale of 1:1, draw the company logo shown, including the outline frame, on one of the faces you have created. [15]

(ii) Add the company name to the rectangular box at the bottom of the logo. [2]

(c) Using a suitable graphical method, complete the remaining two faces of the desk tidy with a visual chart showing:

(i) the numbers and types of vehicle available for hire on one face; [4]

(ii) the rental periods available to customers on the other face. [4]

(d) In the space provided to the right, show a design for holding together the two ends of the card desk tidy without using glue. [2]

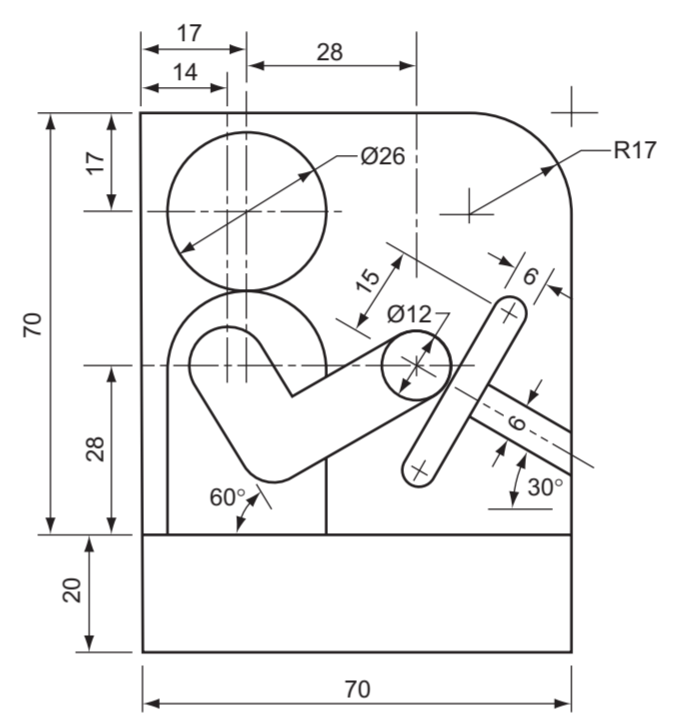

Company Logo

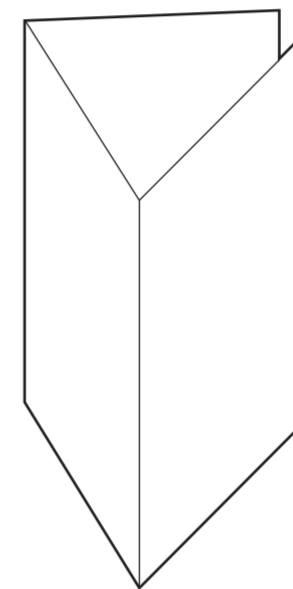

Postcard folded to make a desk tidy

Total Vehicles available for Hire		
Delivery Vans	21	42%
Heavy Trucks	9	18%
Family Cars	12	24%
Sports Cars	8	16%

Rental Periods	
24 Hrs	1 Day
WEEKEND	2 Days
WEEKDAYS	5 Days
WHOLE WEEK	7 Days

Information for part (c)

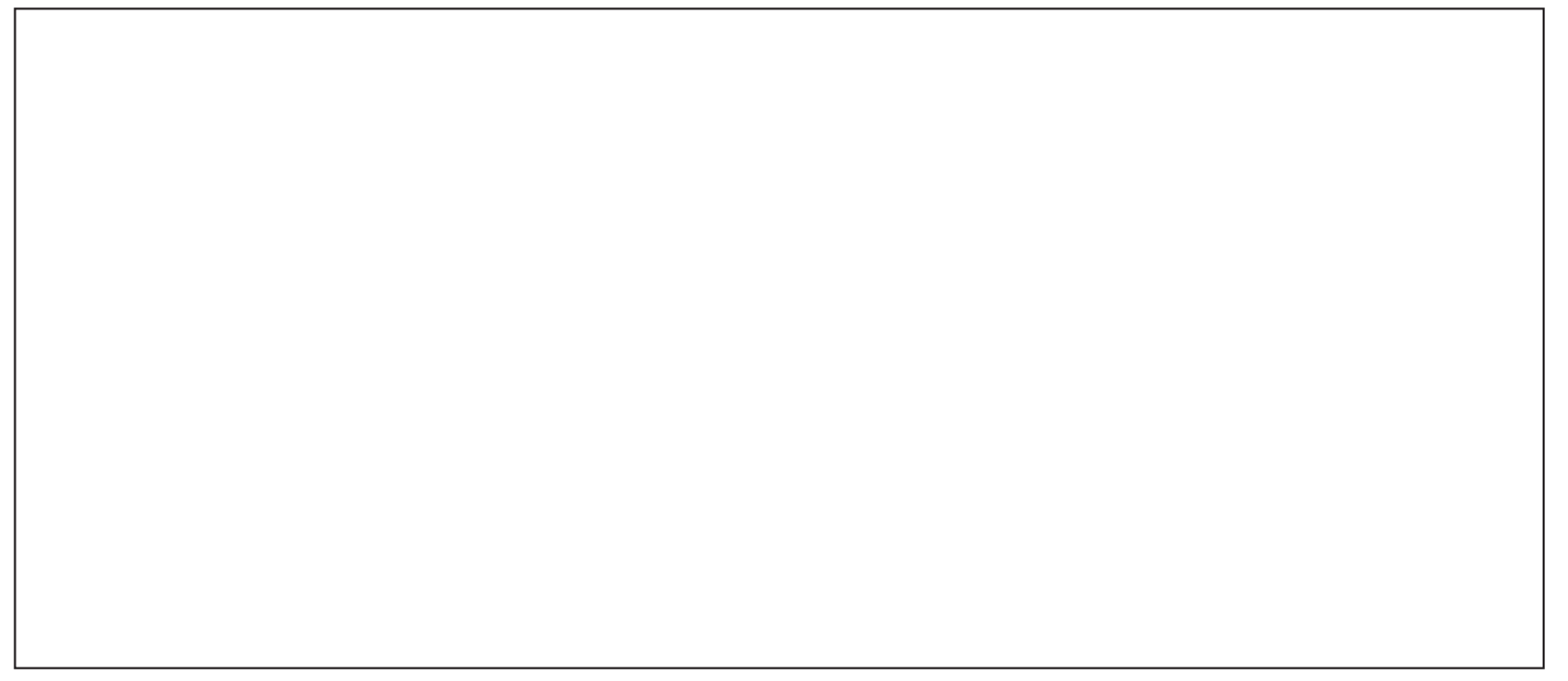

Outline of Postcard

Write your surname, other names, Centre number and candidate number in the spaces provided.
 Answer any **two** questions.
 Draw your answers in the spaces provided on the question paper.
 All dimensions are in millimetres.
 The number of marks is given in brackets [] at the end of each question or part question.

Candidate's Surname
 Other Names
 Centre Number
 Candidate's Number

For Examiner's use

[Turn over

3 An exploded view of component parts for a computer disk storage rack is shown to the right. The two side panels fit into 5×5 rebates in the top and bottom. The two $\text{Ø}8$ rods fit into the $\text{Ø}8$ holes provided in the side panels. The small pictorial sketch shows the parts assembled with one computer disk in the rack.

(a) Draw to a scale of 1:1 in either first or third angle projection, the following views of the assembled rack:

- (i) a sectional view taken through the centre of the rack looking in the direction of arrow S; [12]
- (ii) the end view looking in the direction of arrow EV; [8]
- (iii) the plan. [2]

(b) In the space indicated, draw the symbol for the angle of projection you have used. [2]

Show hidden detail on the plan view only.
Do not show a computer disk in the rack.

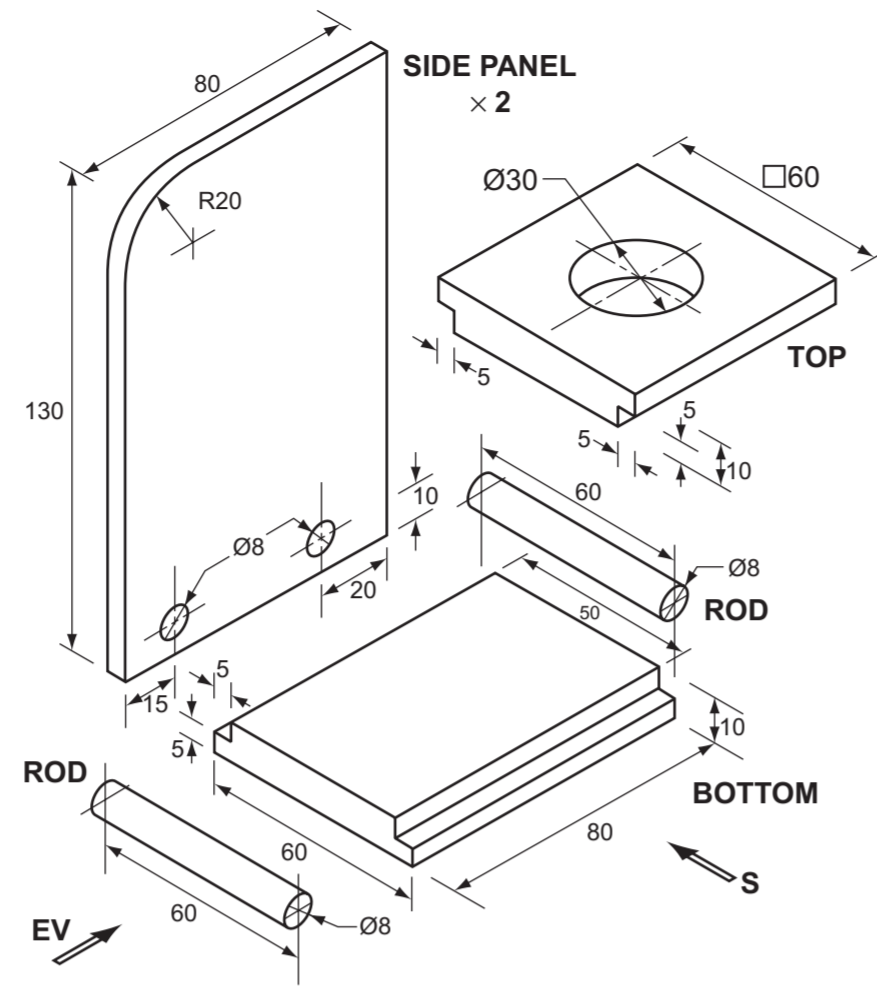
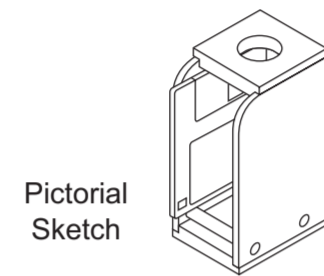

4 A thin card sweet box for a children's party is shown to the right. The box is to have the sweet company logo printed in the area indicated. The name of the company is **WHEELS**.

In the space below:

- (a) sketch **two** ideas for the logo which must represent the name of the company; [4]
- (b) complete the full size, one-piece development of the sweet box. The bottom of the box has been drawn for you. Include all gluing and other flaps; [16]
- (c) draw accurately your chosen design for the logo on the correct part of the development; [3]
- (d) add to the development you have drawn, a carrying handle that will keep the box closed when it is carried; [4]
- (e) add colour to the **logo** to enhance its appearance. [3]

ANSWER (a) HERE

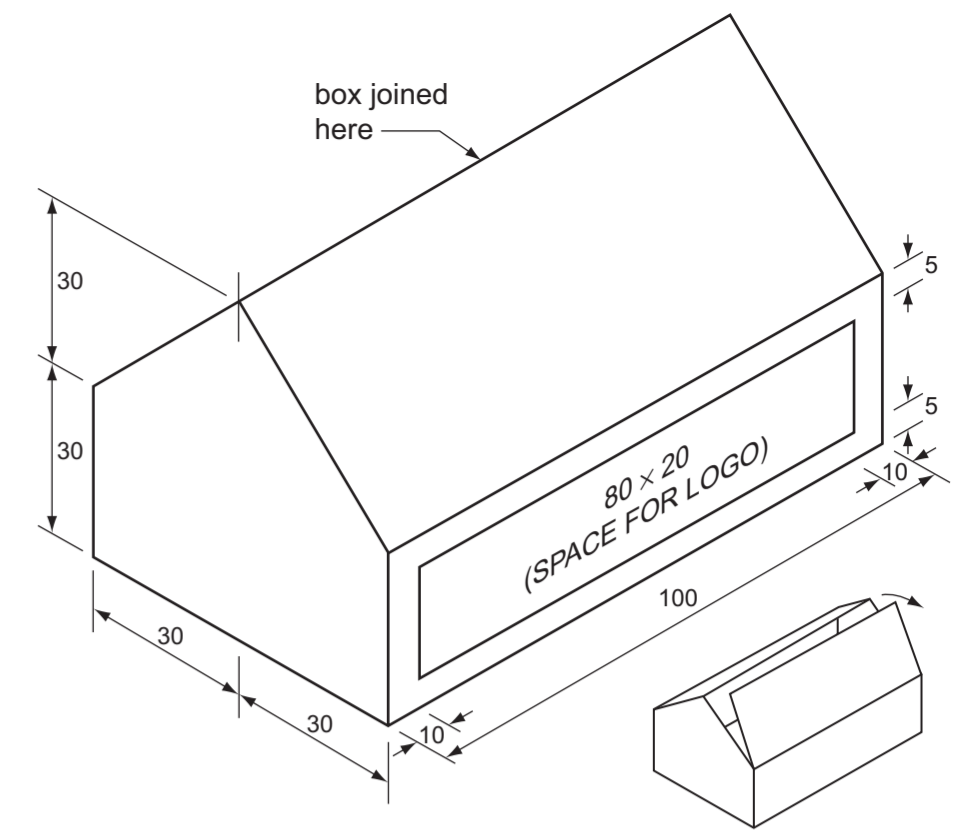

ANSWER (b) HERE

DRAW THE SYMBOL FOR THE ANGLE OF PROJECTION USED HERE

