

Centre Number	Candidate Number	Name
---------------	------------------	------

UNIVERSITY OF CAMBRIDGE INTERNATIONAL EXAMINATIONS  
International General Certificate of Secondary Education

**DESIGN AND TECHNOLOGY**

**0445/03**

Paper 3 Realisation

October/November 2006

**1 hour**

Candidates answer on the Question Paper.  
No Additional Materials are required.

**To be taken together with Paper 1 in one session of 2 hours 45 minutes.**

**READ THESE INSTRUCTIONS FIRST**

Write your Centre number, candidate number and name on all the work you hand in.  
Write in dark blue or black pen.  
You may use a soft pencil for any diagrams, graphs or rough working.  
Do not use staples, paper clips, highlighters, glue or correction fluid.

Answer **two** questions.  
You may use a calculator.  
The number of marks is given in brackets [ ] at the end of each question or part questions.  
At the end of the examination, fasten all your work securely together.

FOR EXAMINER'S USE	
1	
2	
3	
4	
<b>TOTAL</b>	

This document consists of **18** printed pages and **2** blank pages.

- 1 Fig. 1 shows the basic design for an adjustable mirror. The side view shows details of a mirror tile and its backing material.

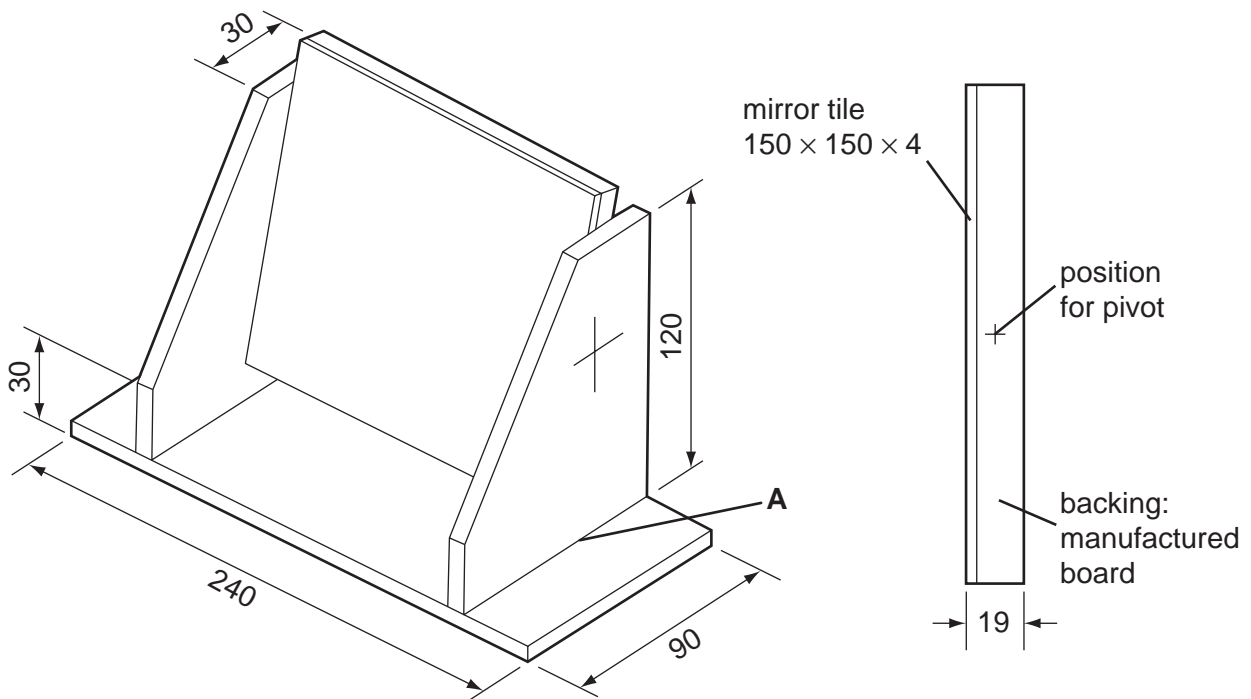
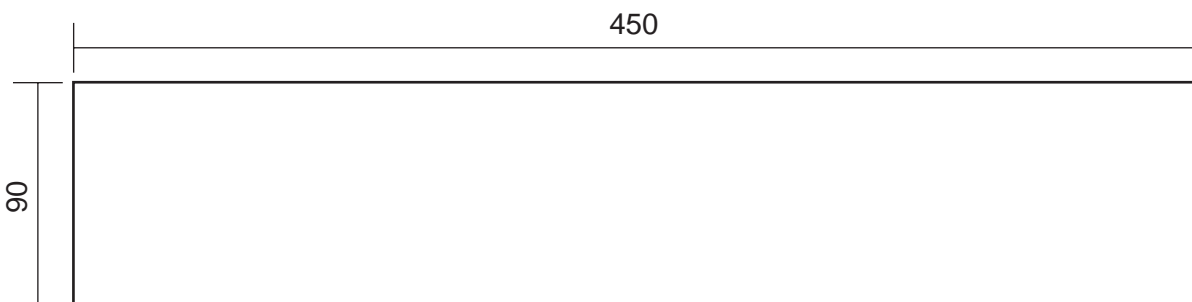

Fig. 1

- (a) The base and uprights are to be cut from a single length of hardwood as shown in Fig. 2. Complete Fig. 2 to show how the base and uprights could be marked out to avoid waste.



SCALE 1:3

Fig. 2

[5]

(b) (i) Give **two** reasons why a manufactured board rather than a solid wood is used for the mirror backing.

1 .....

2 ..... [2]

(ii) Name a suitable adhesive that could be used to glue the mirror tile to the manufactured board backing.

..... [1]

(c) (i) Name **two** methods of joining the upright to the base at **A**.

1 .....

2 ..... [2]

(ii) Sketch **one** of the joining methods you have named in **part (c) (i)**.

[4]

(iii) Use notes and sketches to show **four** of the main stages in making **one** of the joints named in **part (c) (i)**.

Do **not** include marking out.

Chosen joint .....

Stage 1

[2]

Stage 2

[2]

Stage 3

[2]

Stage 4

[2]

(d) Fig. 3 shows a side view of the adjustable mirror with the right hand upright removed.

The mirror is pivoted between the uprights and is to be held at any angle between  $0^\circ - 45^\circ$ .

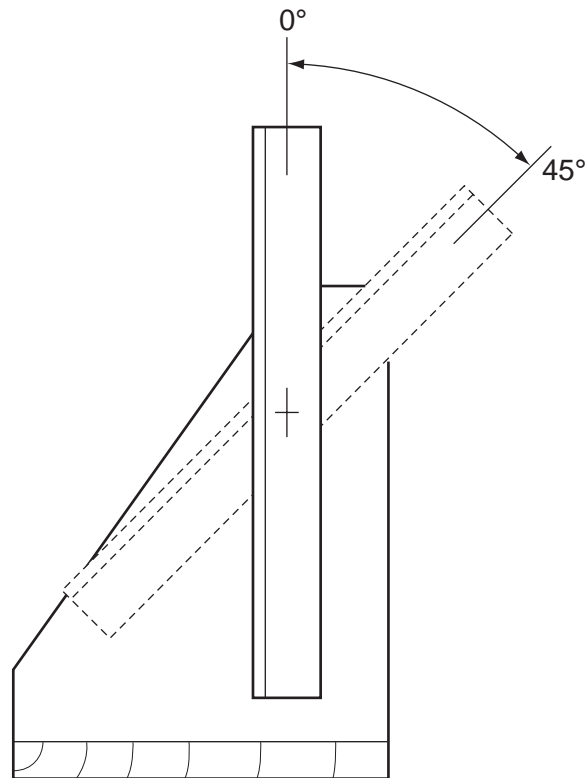

**Fig. 3**

Use notes and sketches to show a suitable pivot and locking method by which the mirror could be held at any angle, ( $0^\circ - 45^\circ$ ), between the uprights.

Name the materials and fittings you would use.

[8]

2 Fig. 4 shows views of a free-standing clock.

The clock is made from two separate pieces of acrylic.

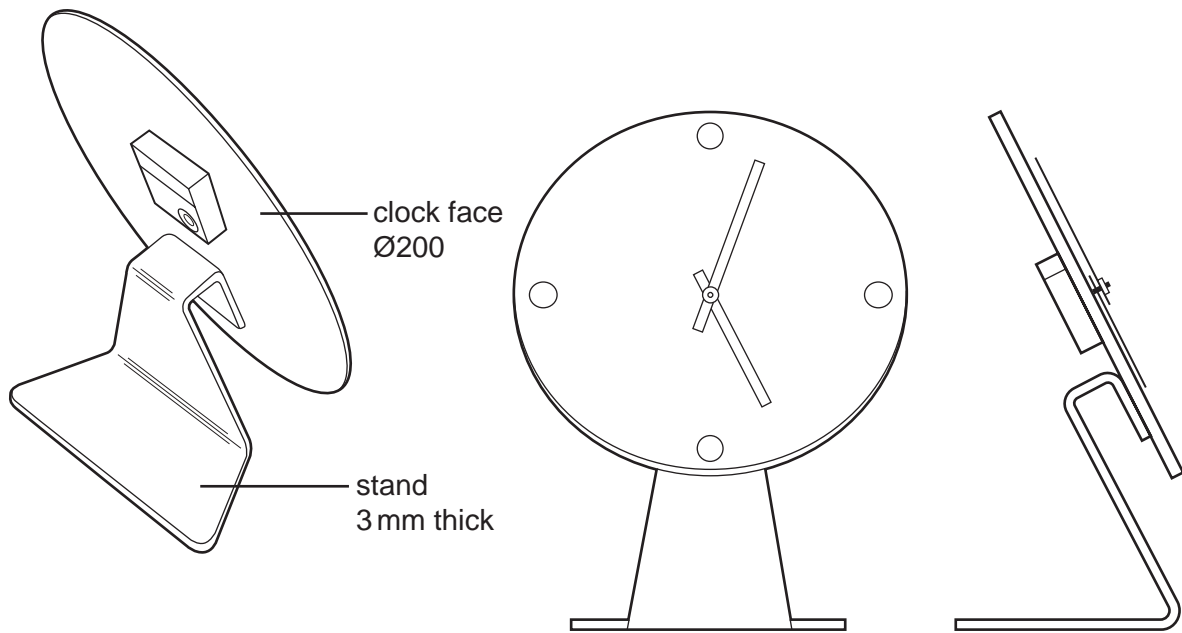

Fig. 4

(a) State **two** properties of acrylic that makes it a suitable material for this clock.

1 .....

2 ..... [2]

(b) Give **two** reasons why a designer would construct a mock-up model of the clock before making it from acrylic.

1 .....

2 ..... [2]

(c) Use notes and sketches to show how the clock stand could be **marked out** on one piece of acrylic.

[8]

(d) Name **two** tools that could be used to mark out the shape.

1 .....

2 ..... [2]

(e) Use notes and sketches to describe the following stages when producing the two 90° bends in the clock stand.

(i) Heating the plastic.

[3]

(ii) Bending the plastic to the required shape.

[5]



(f) Describe **three** of the main stages in finishing the edges of the acrylic.

1 .....  
.....  
2 .....  
.....  
3 .....  
..... [3]

(g) There is a risk that sheet acrylic could crack when being drilled.

Describe how this risk can be minimised.

.....  
..... [2]

(h) (i) Name a solvent used to fix the clock face to the stand.

..... [1]

(ii) State **two** safety precautions you would take when using solvents.

1 .....  
2 ..... [2]

3 Fig. 5 shows details of a table on which drinks and snacks could be placed.

The table top can be adjusted to different heights.

The table top has been lifted off to show the frame to which it will be attached.

table top:  
melamine faced  
manufactured board

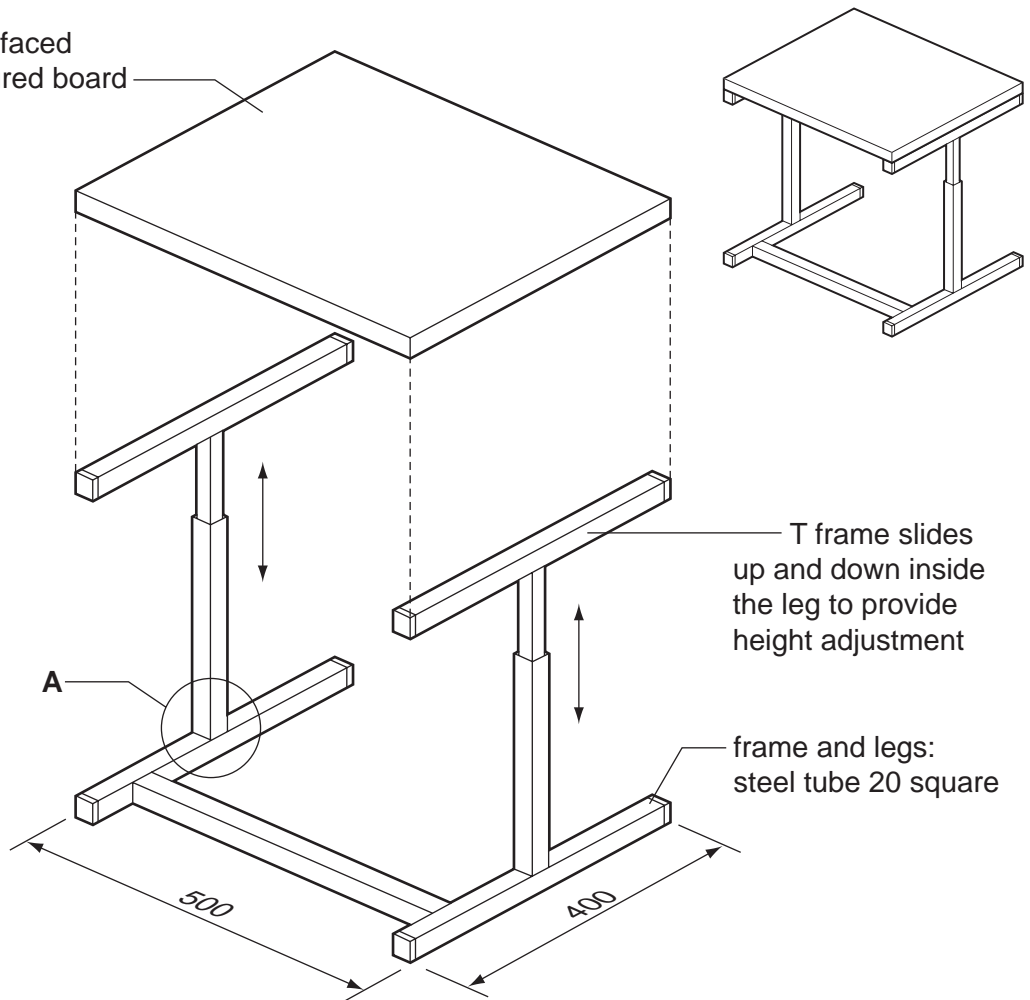

Fig. 5

(a) Name a suitable manufactured board for the table top.

..... [1]

(b) Manufactured boards without a melamine facing require an applied finish.

(i) State a suitable finish for the table top and give **one** reason for your choice.

Finish .....

Reason ..... [2]

(ii) Use notes and sketches to describe how the table top is prepared and your chosen finish applied.

[4]

- (c) The table top is to be connected to the T frame by a method that allows it to be removed for maintenance.

Use notes and sketches to show a suitable method.

[4]

- (d) Use notes and sketches to show how the T frame could be adjusted and locked at **three** different heights. Give details of any fittings you use.

[4]

(e) Use notes and sketches to show **two** improvements you could make to the design of the table top.

Improvement 1

[2]

Improvement 2

[2]

(f) State **two** methods of joining the steel tube at **A**.

1 ..... [2]

2 ..... [2]

**(g)** Use notes and sketches to show the following stages when making the tubular steel frame.

**(i)** Marking the steel tube to length.

[3]

**(ii)** Cutting the steel tube to length.

[3]

**(iii)** Squaring the ends of the steel tube.

[3]

- 4 Fig. 6 shows an incomplete DVD storage unit made mainly from a good quality hardwood. The unit will store twenty DVDs. Four DVDs are shown in position.

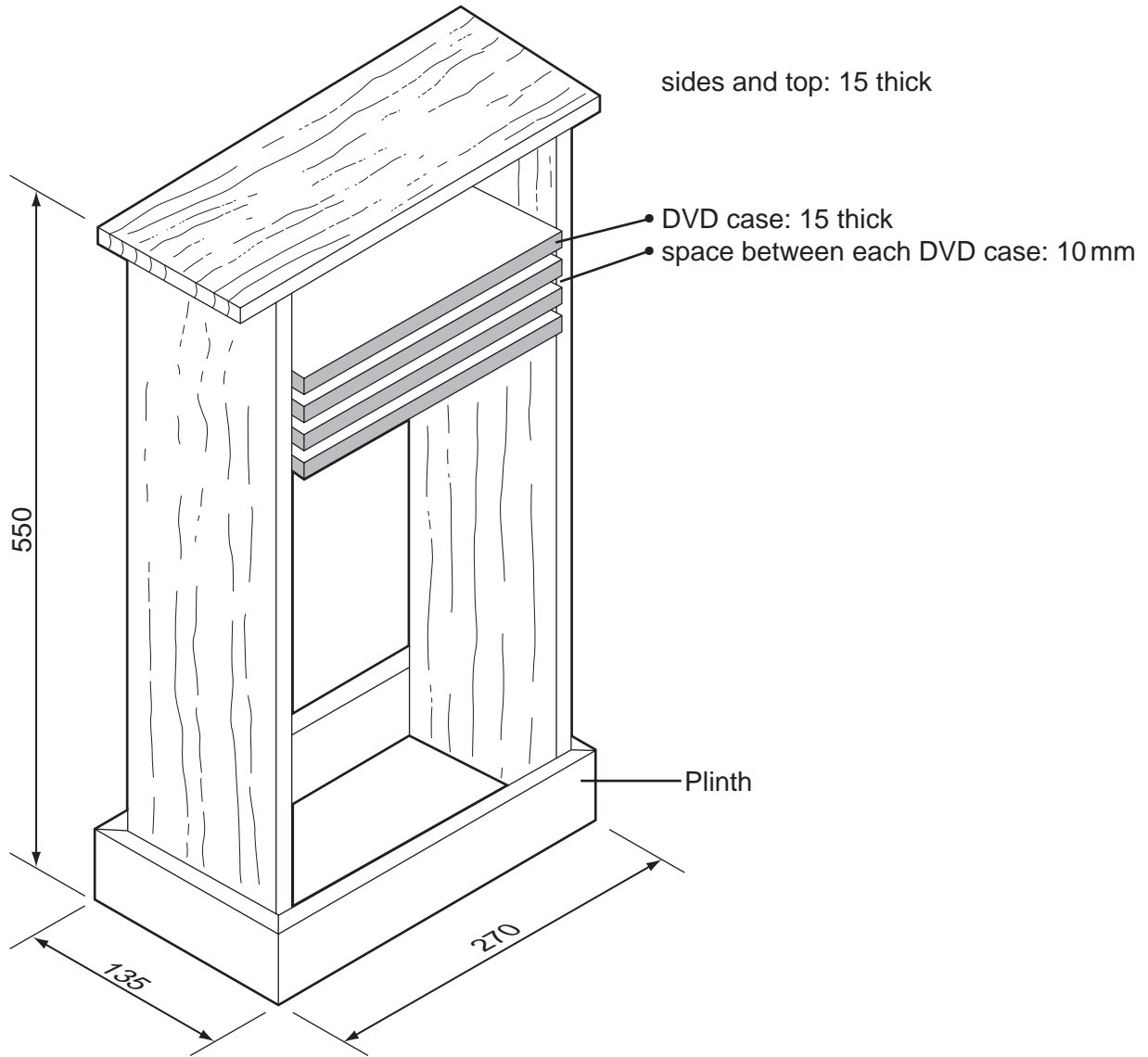

Fig. 6

(a) State **two** visual characteristics of hardwoods that give them a high-quality appearance.

1 .....

2 ..... [2]

(b) Give **three** design requirements for the DVD storage unit.

1 .....

2 .....

3 ..... [3]

(c) Fig. 7 shows a length of hardwood from which the two sides and the top are to be made.

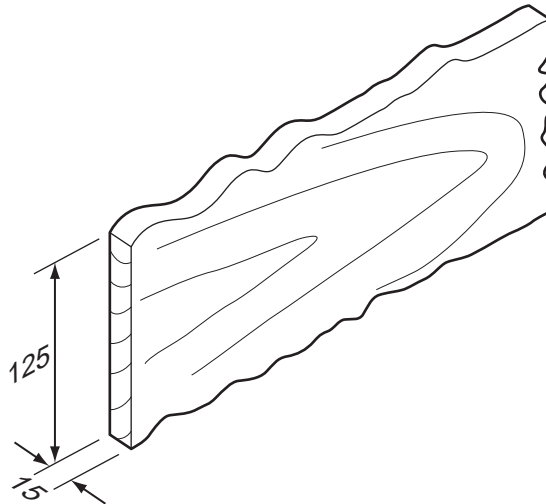

Fig. 7

Name **three** tools that would be used to prepare the wood to the finished width of 120 mm.

- 1 .....
- 2 .....
- 3 ..... [3]

(d) Use notes and sketches to show how:

(i) the DVDs are spaced 10 mm apart within the storage unit;

[5]

(ii) the DVDs could be prevented from falling through the back of the unit.

[5]



- (e) Fig. 8 shows the plinth made from four pieces of wood joined at the corners by means of a glued mitre joint.

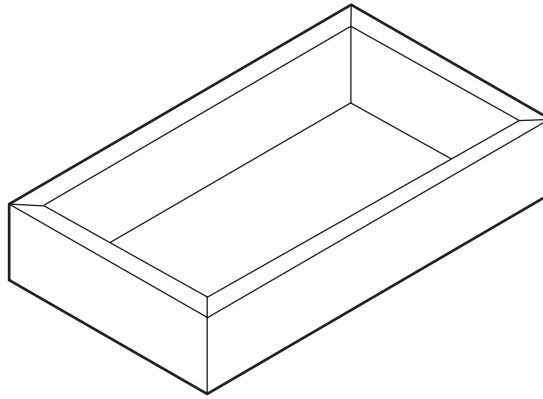

**Fig. 8**

Use notes and sketches to show how the following stages could be carried out:

- (i) marking out the 45° mitres;

[3]

- (ii) cutting the mitres at 45°;

[3]

(iii) holding the four sides together while the glue is setting;

[3]

(iv) checking that the plinth is square.

[3]

**BLANK PAGE**

**BLANK PAGE**

---

Permission to reproduce items where third-party owned material protected by copyright is included has been sought and cleared where possible. Every reasonable effort has been made by the publisher (UCLES) to trace copyright holders, but if any items requiring clearance have unwittingly been included, the publisher will be pleased to make amends at the earliest possible opportunity.

University of Cambridge International Examinations is part of the University of Cambridge Local Examinations Syndicate (UCLES), which is itself a department of the University of Cambridge.