



UNIVERSITY OF CAMBRIDGE INTERNATIONAL EXAMINATIONS
International General Certificate of Secondary Education

CANDIDATE NAME

CENTRE NUMBER

CANDIDATE NUMBER

* 8 8 5 7 7 1 1 1 5 0 *

DESIGN AND TECHNOLOGY

0445/04

Paper 4 Systems and Control

October/November 2007

1 hour

Candidates answer on the Question Paper.

No Additional Materials are required.

To be taken together with Paper 1 in one session of 2 hours 15 minutes.

READ THESE INSTRUCTIONS FIRST

Write your Centre number, candidate number and name on all the work you hand in.

Write in dark blue or black pen.

You may use a soft pencil for any diagrams or graphs.

Do not use staples, paper clips, highlighters, glue or correction fluid.

DO NOT WRITE IN ANY BARCODES.

Section A

Answer **all** questions.

Section B

Answer **one** question.

You may use a calculator.

At the end of the examination, fasten all your work securely together.

The number of marks is given in brackets [] at the end of each question or part question.

For Examiner's Use	
Section A	
Section B	
Total	

This document consists of **14** printed pages and **2** blank pages.



Section A

Answer **all** questions in this section.

1 Complete the statement below:

A tie is a structural member experiencing force. [1]

2 Identify the electrical component shown below.

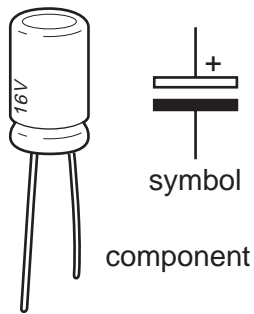

The component shown is [2]

Give one use of this component. [1]

3 Complete the table below.

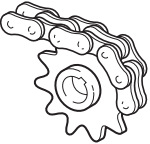
Name	Diagram	Use
Pear cam and flat follower		Valve operation
		Bicycle transmission

[3]

4 Identify the class (order) of lever shown below:

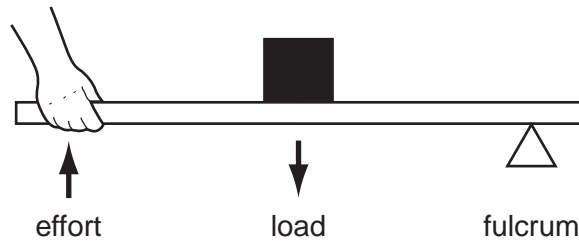

The lever shown is [1]

Give an example of the use of this class of lever.

..... [1]

5 The diagram below shows a linkage.

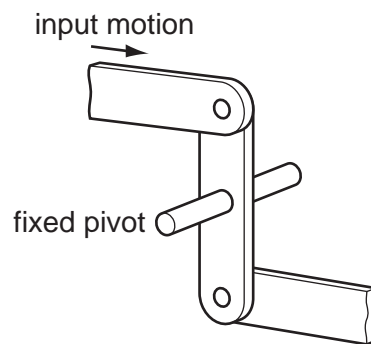

(a) Add labels to show the direction of the output motion. [2]

(b) Name the type of motion shown in the diagram of the linkage above.

..... [1]

(c) Explain the function of this linkage.

..... [2]

6 Complete the table below.

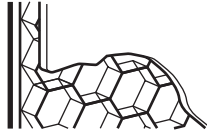
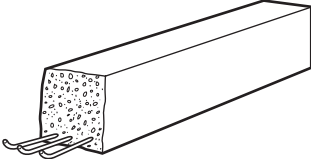
Name	Diagram	Use
Honeycomb cells		[1]
[1]		[1]
'I' Section beam	[2]	Steel framed buildings

7 Identify the logic gate shown in the diagram below.

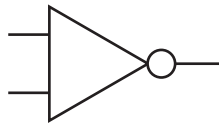

..... [1]

8 (a) State the purpose of an LDR transducer.

..... [1]

(b) Give **one** example of the use of an LDR.

..... [1]

9 Give **one** example of the use of a strain gauge.

..... [1]

10 Name **two** methods of reinforcing a square framed structure.

..... [2]

Section B

Answer **one** question from this section.

11 Fig.1 shows a hand drill.

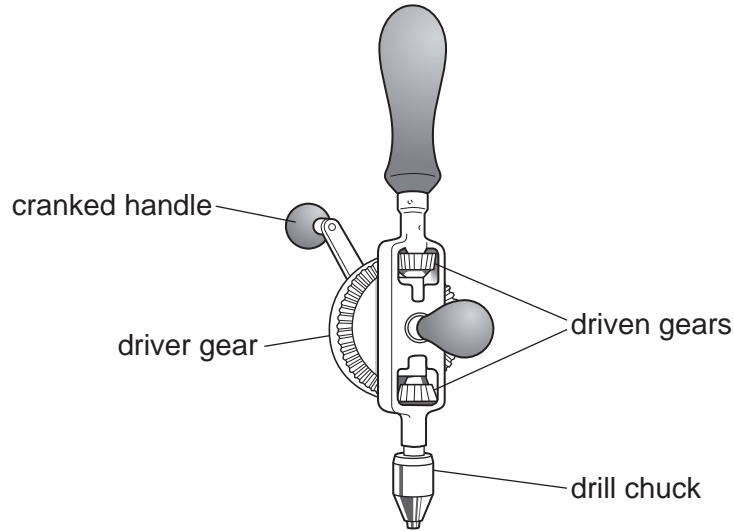

Fig. 1

(a) Describe the motion conversion that takes place when using a hand drill.

.....

.....

.....

..... [2]

(b) (i) Name the type of gear mechanism used in the hand drill shown.

..... [1]

(ii) Explain why the driver gear wheel is very much larger than the driven gear wheels.

.....

.....

..... [2]

(iii) Give **one** reason for the top driven gear wheel nearest the handle.

.....
.....
..... [2]

(c) Explain why the handle is cranked.

.....
.....
.....
.....
..... [3]

(d) The driver wheel has 60 teeth and the driven wheels have 12 teeth each.

(i) Calculate the gear ratio for this mechanism.

[3]

(ii) If the driver wheel is turned at 60 rpm, calculate the speed of the drill chuck.

[3]

(e) Fig. 2 shows a toothed belt drive arrangement.

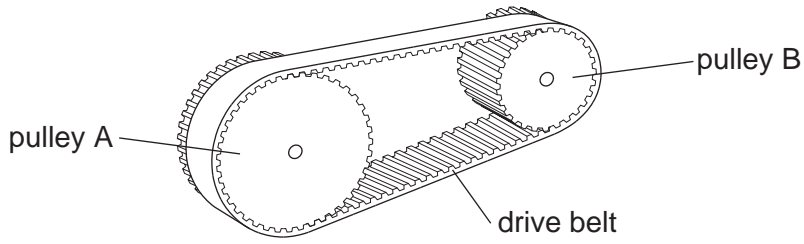

Fig. 2

(i) Give **one** benefit of using this type of belt drive.

.....
 [1]

(ii) Explain **one** drawback of using this type of belt drive.

.....

 [2]

(iii) Give **one** example of the use of this type of belt drive.

..... [1]

(iv) Explain how you would calculate the Velocity Ratio of this belt drive.

.....

 [3]

(f) Give **one** other type of pulley drive belt and give **one** use.

.....

 [2]

12 Fig.3 shows a variety of both natural and man made structures.

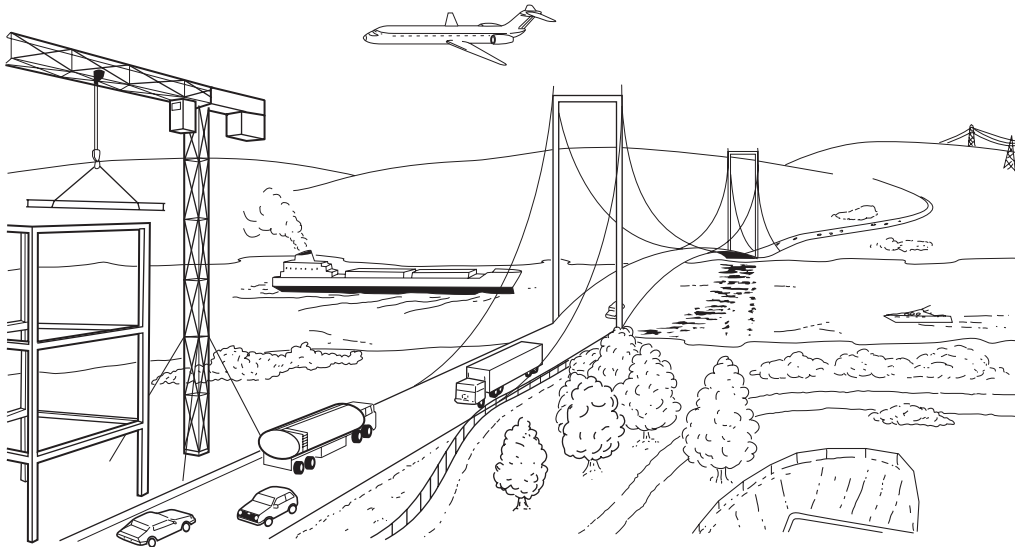

Fig. 3

(a) (i) Name **one** frame structure in Fig.3.

.....
..... [1]

(ii) Name **one** man made shell structure in Fig.3.

..... [1]

(b) Explain the difference in the way in which frame and shell structures work.

.....
.....
.....
.....
..... [2]

(c) Explain the following functions of a structure.

Support:
.....
..... [2]

Span:
.....
..... [2]

Contain:
.....
..... [2]

(d) Structures can be subjected to static and dynamic forces.

Explain, using examples, the difference between static and dynamic forces.

.....
.....
.....
.....
..... [3]

(e) Fig. 4 shows a structure for a roof truss.

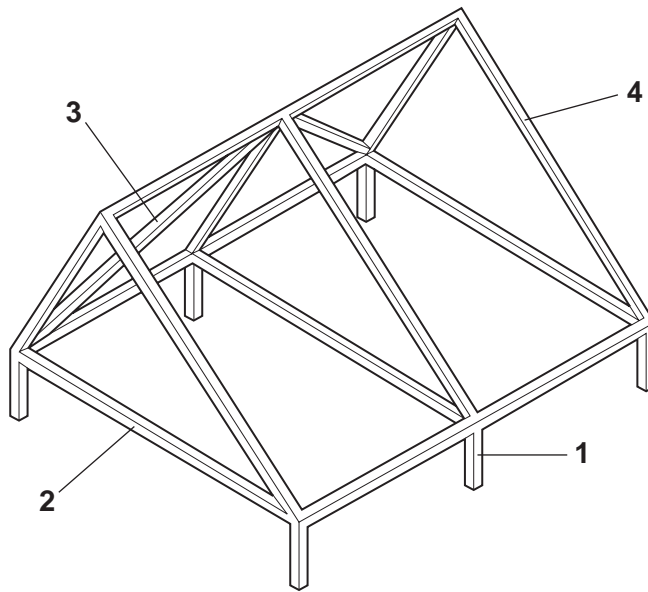

Fig. 4

(i) Name the parts numbered 1 to 3.

- 1 [1]
- 2 [1]
- 3 [1]

(ii) Part 4 is a strut.

Use sketches and notes to explain the type of load experienced by a strut.

[2]

(iii) Use sketches and notes to explain why the roof truss is made up of triangles.

[2]

(iv) Draw **one** method of reinforcing the joints in the roof truss.

[2]

(f) Use notes and sketches to explain the term redundant member.

[3]

13 Fig. 5 shows a counting circuit triggered by a photoswitch.

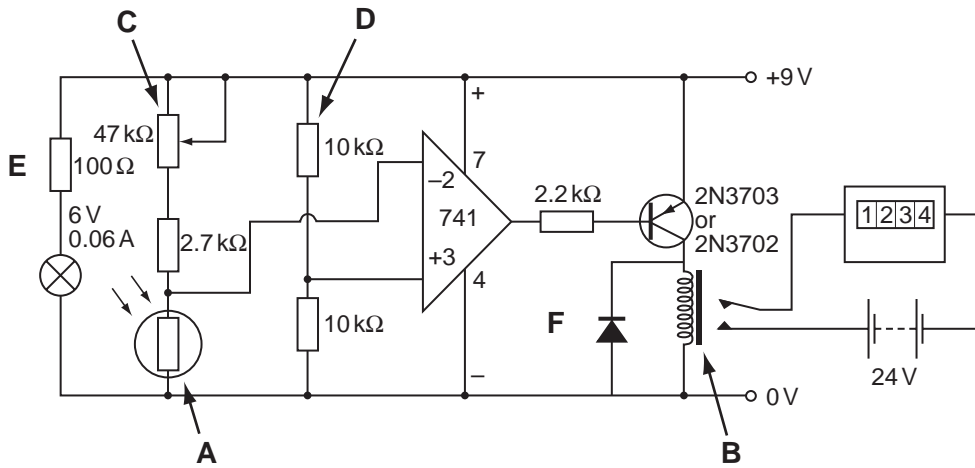
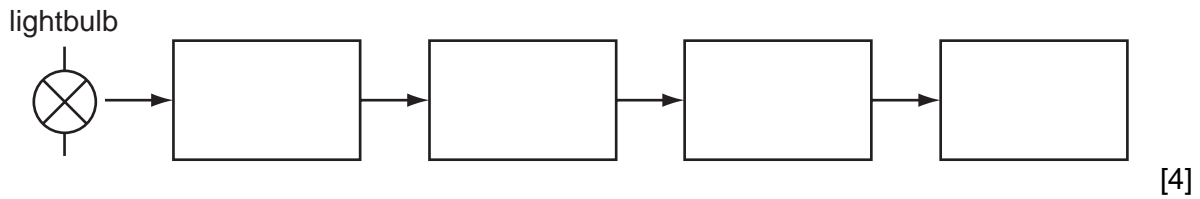

Fig. 5

(a) Complete the block diagram to explain how this counting circuit works each time the light beam, shining on component A, is broken.



(b) (i) Name component B.

..... [1]

(ii) Explain the purpose of component B in this circuit.

.....

 [3]

(iii) Explain the need for component F.

.....

 [2]

(iv) Explain the purpose of component **C**.

.....
.....
.....
.....
..... [3]

(v) State the purpose of the resistor **E**.

.....
..... [1]

(c) The pair of 10 kΩ resistors labelled **D** are known as a potential divider.

Explain the term potential divider.

.....
.....
.....
..... [3]

(d) Explain how the circuit shown in Fig. 5 could be simply modified to count when the light beam is shining on component **A**.

.....
.....
..... [3]

- (e) Logic gates could be used to control a counter. Fig. 6 shows a pressure pad circuit that is used to trigger a counter when a person steps on pad **P** and, at the same time, presses the push button **Q**.

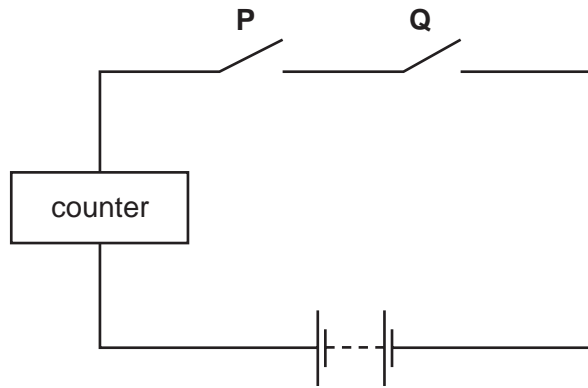

Fig. 6

- (i) Complete the truth table below for this logic circuit.

Pad P On/Off	Pad Q On/Off	Counter state On/Off
Off	Off	Off
Off	On	
On	Off	
		On

[4]

- (ii) Identify the type of logic circuit shown.

.....

[1]

BLANK PAGE

Permission to reproduce items where third-party owned material protected by copyright is included has been sought and cleared where possible. Every reasonable effort has been made by the publisher (UCLES) to trace copyright holders, but if any items requiring clearance have unwittingly been included, the publisher will be pleased to make amends at the earliest possible opportunity.

University of Cambridge International Examinations is part of the Cambridge Assessment Group. Cambridge Assessment is the brand name of University of Cambridge Local Examinations Syndicate (UCLES), which is itself a department of the University of Cambridge.