

UNIVERSITY OF CAMBRIDGE INTERNATIONAL EXAMINATIONS
International General Certificate of Secondary Education

**MARK SCHEME for the October/November 2009 question paper
for the guidance of teachers**

0445 DESIGN AND TECHNOLOGY

0445/04 Paper 4 (Technology), maximum raw mark 50

This mark scheme is published as an aid to teachers and candidates, to indicate the requirements of the examination. It shows the basis on which Examiners were instructed to award marks. It does not indicate the details of the discussions that took place at an Examiners' meeting before marking began, which would have considered the acceptability of alternative answers.

Mark schemes must be read in conjunction with the question papers and the report on the examination.

- CIE will not enter into discussions or correspondence in connection with these mark schemes.

CIE is publishing the mark schemes for the October/November 2009 question papers for most IGCSE, GCE Advanced Level and Advanced Subsidiary Level syllabuses and some Ordinary Level syllabuses.



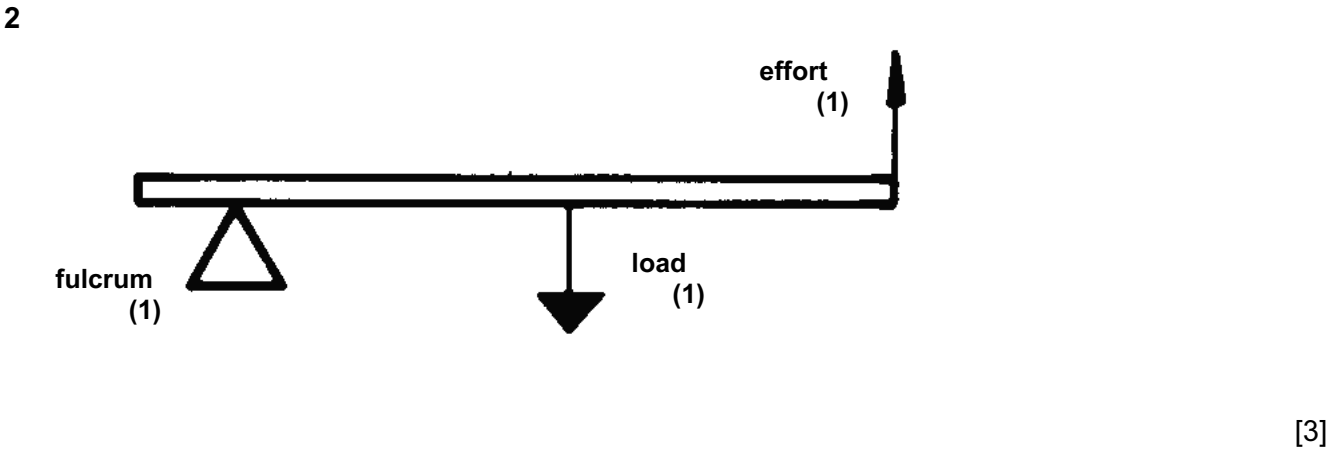

Section A

- 1 (a) **A** Framework [1]
B Shell [1]
- (b) (i) Good strength to weight ratio (1) and combines the structural properties of both materials (1) [2]
(ii) Plywood / internal doors / aircraft wing / display-board [1]

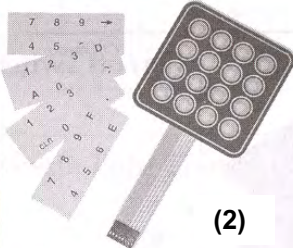

3 Complete the table showing a selection of electrical switches.

Type	Appearance	Application
REED (1)		Non-contact operation by magnet for detecting the opening or closing of doors/windows
Tilt		DETECTS MOVEMENT (1)
Membrane panel	 (2)	Waterproof keypads

[4]

4 (a)

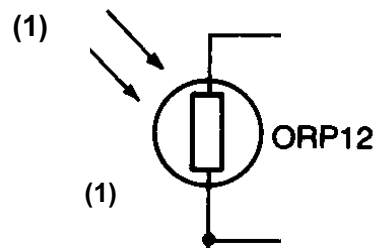

[2]

(b) Burglar alarm / movement detection / light level alarm

[1]

5 (a) Speed of the driven gear = speed of driver × gear ratio (R)

$$R = \text{Teeth on driver} / \text{Teeth on driven} = 18 / 12 \text{ (1)}$$

$$R = 3 / 2 \text{ (1)}$$

$$\text{Speed} = 200 \times 3 / 2 = 300 \text{ rpm (1)}$$

[3]

(b) Add an idler gear (1) between the driver and driven gears (1)

[2]

6 OR

[1]

7 Cantilever

[1]

8 First

[1]

9 Drilling machine / lathe

[1]

10 Reduce friction / reduce wear and tear / energy efficiency

[1]

Section B

11 (a) Washing machine programme controller / alarms [1]

(b) (i)

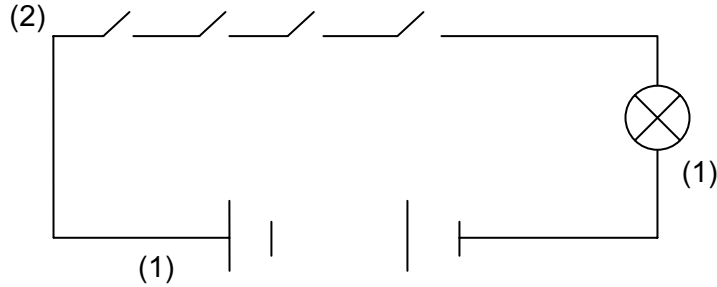

[4]

(ii) Sketch the circuit symbol for a **NAND** gate.

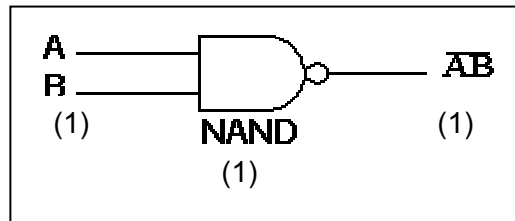

[3]

(iii) Complete the truth table below for a **NAND** gate.

Input A	Input B	Output
0	0	1
0	1	1
1	0	1
1	1	0

[3]

(b) (i)

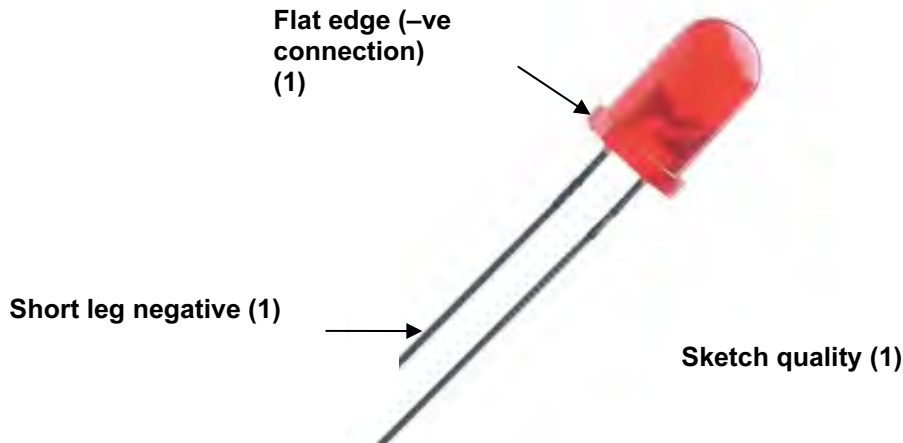

[3]

(ii) Protective resistor (1) that reduces current flow through LED (1)

[2]

(iii) $V = IR$

$$I = V / R \text{ (1)}$$

$$I = 9 / 470 \text{ (1)}$$

$$I = 0.019 \text{ A (1)}$$

[3]

(iv) 1 Last longer / more robust

[1]

2 Smaller / range of colours

[1]

(v) Parallel

[1]

(c) 1st: Yellow

[1]

2nd: Violet

[1]

3rd: Brown

[1]

12 (a) Head: Reciprocating [1]
 Legs: Oscillating [1]

(b) Quality of response (1)

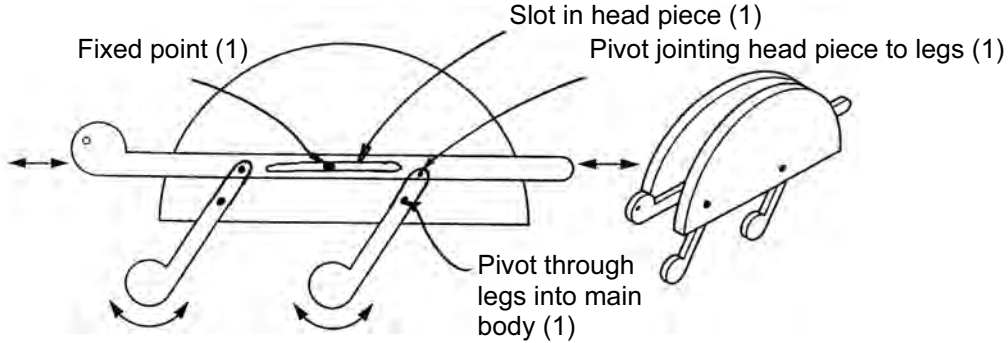

[5]

(c) (i) Annotations (1)
 Quality of response (1)

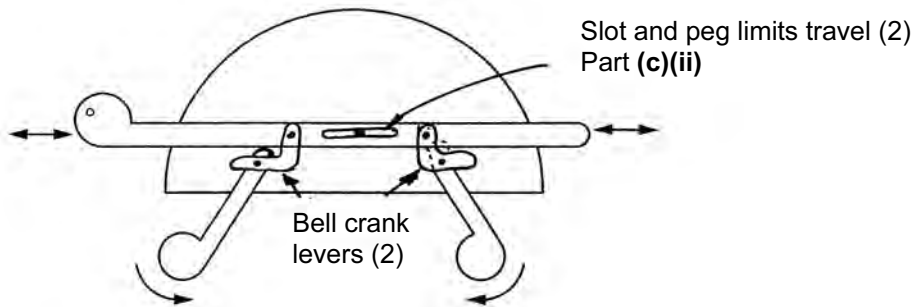

[4]

(ii) See Figure above

[2]

(iii)

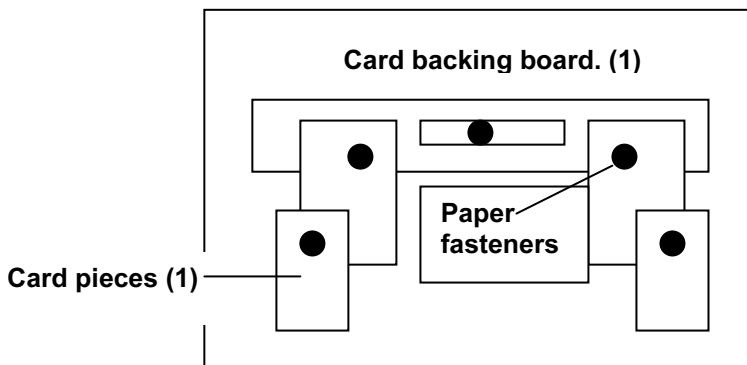

[3]

(iv) Saves materials (1); simulates movement exactly (1)

[2]

Page 7	Mark Scheme: Teachers' version	Syllabus	Paper
	IGCSE – October/November 2009	0445	04

- (d) (i) Guitar tuner [1]
- (ii) Enables precise, small incremental movements (1) and enables great speed reductions / change axis of rotation (1) [2]
- (iii) Ratio = 1: 40 [1]
- (iv) If the speed of the worm is 200 rpm calculate the output speed from the wormwheel.
 Output speed = Input speed \times 1 / 40
 Output speed = 200 / 40 (1)
 Output speed = 5 rpm (1) [2]

13 (a) (i)

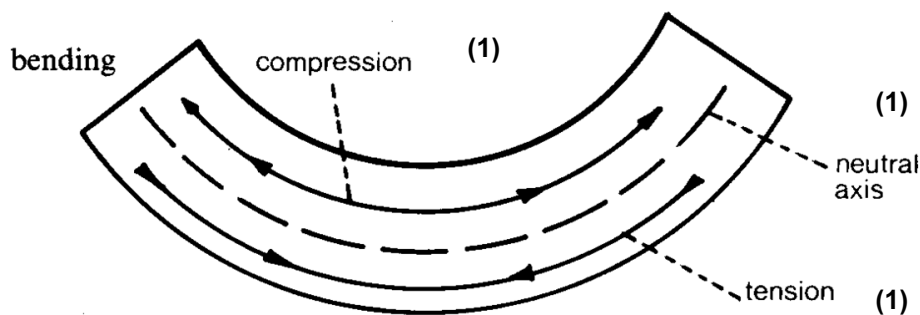

- [3]
- (ii) Add vertical strip across the underside of the shelf [3]

(b) Reactions at L and R.

$$R + L = 30 \text{ N}$$

$$R \times 1.2 = (0.25 \times 10) + (0.55 \times 15) + (0.95 \times 5) \text{ (1)}$$

$$R = \frac{2.5 + 8.25 + 4.75}{1.25} \text{ (1)}$$

$$R = 12.92 \text{ N (1)}$$

$$L = 30\text{N} - 12.92 \text{ N} = 17.08 \text{ N (1)}$$

[4]

(c) (i)



[3]

(ii) Tension / Tensile

[1]

(iii) All internal forces (1) are balanced by all external forces (1)

[2]

(iv)

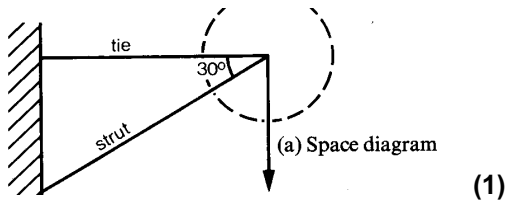

$$F_T = 10 / \tan 30 \quad (1)$$

$$F_T = 10 / 0.577 = 17.33 \text{ N} \quad (1)$$

$$F_S = 10 / \sin 30 \quad (1)$$

$$F_S = 10 / 0.5 = 20.0 \text{ N} \quad (1)$$

[5]

(d) (i)

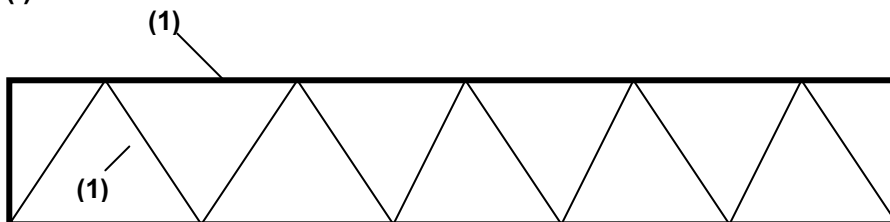

[2]

(ii) Good strength to weight ratio (1) and a low cost material (1) that can be recycled (1) [3]