



UNIVERSITY OF CAMBRIDGE INTERNATIONAL EXAMINATIONS  
International General Certificate of Secondary Education

CANDIDATE  
NAME

CENTRE  
NUMBER

--	--	--	--	--

CANDIDATE  
NUMBER

--	--	--	--



**CHEMISTRY**

**0620/02**

Paper 2

**October/November 2008**

**1 hour 15 minutes**

Candidates answer on the Question Paper.

No Additional Materials are required.

**READ THESE INSTRUCTIONS FIRST**

Write your Centre number, candidate number and name in the spaces at the top of this page.

Write in dark blue or black pen.

You may need to use a pencil for any diagrams, graphs or rough working.

Do not use staples, paper clips, highlighters, glue or correction fluid.

**DO NOT WRITE IN ANY BARCODES.**

Answer **all** questions.

A copy of the periodic table is printed on page 16.

At the end of the examination, fasten all your work securely together.

The number of marks is given in brackets [ ] at the end of each question or part question.

For Examiner's Use	
1	
2	
3	
4	
5	
6	
7	
<b>Total</b>	

This document consists of **16** printed pages.



- 1 (a) The table gives some information about five elements, A, B, C, D and E. Complete the table by writing either metal or non-metal in the last column.

element	properties	metal or non-metal
A	shiny solid which conducts electricity	
B	reddish brown liquid with a low boiling point	
C	a form of carbon which is black in colour and conducts electricity	
D	white solid which is an insulator and has a high melting point	
E	dull yellow solid which does not conduct heat	

[5]

- (b) Describe how metallic character changes across a Period.

..... [1]

- (c) Sodium is in Group I of the Periodic Table.

- (i) Draw a diagram to show the full electronic structure of sodium.

[1]

- (ii) Complete the equation to show what happens when a sodium atom forms a sodium ion.



(d) Complete these sentences about the properties of the Group I elements using words from the list.

*For  
Examiner's  
Use*

**acidic**

**basic**

**decrease**

**hard**

**increase**

**lithium**

**potassium**

**soft**

The Group I elements are relatively ..... metals which ..... in reactivity going down the Group. Sodium reacts more violently with water than .....

The Group I metals all form ..... oxides. [4]

[Total: 12]

- 2 (a) Match up the atmospheric pollutants on the left with their main source on the right. The first one has been done for you.

For  
Examiner's  
Use

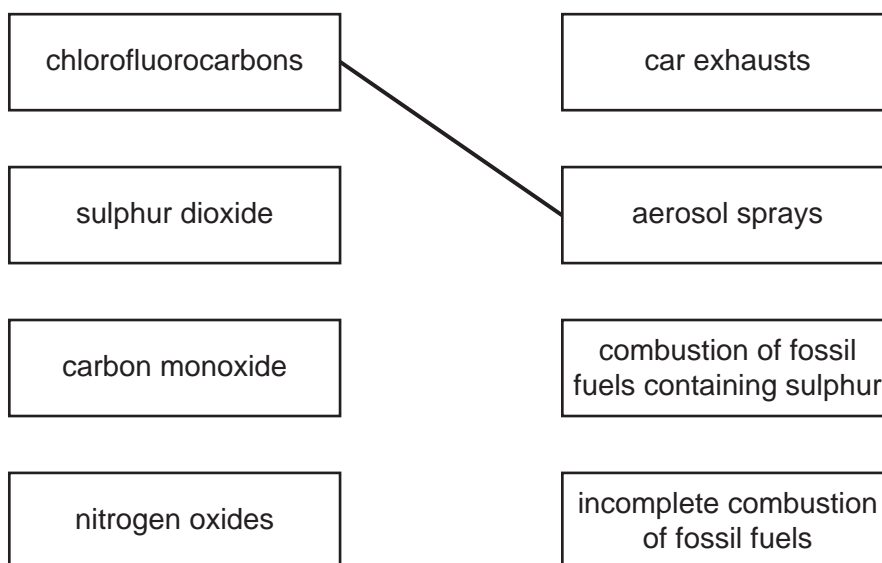

[3]

- (b) One stage in the manufacture of sulphuric acid involves the oxidation of sulphur dioxide by oxygen in the air to form sulphur trioxide.

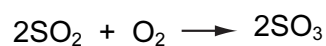

- (i) Explain how this reaction shows that sulphur dioxide is oxidized.

..... [1]

- (ii) What is the percentage of oxygen in clean air? .....

[1]

- (iii) Sulphuric acid is used to make the fertiliser ammonium sulphate.

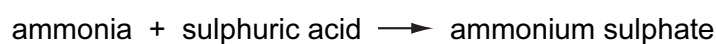

What type of reaction is this?

..... [1]

(iv) Why do farmers need to use fertilisers?

.....  
..... [2]

(v) Another fertiliser can be made by the reaction of ammonia with nitric acid.  
State the chemical name of this fertiliser.

..... [1]

[Total: 9]

*For  
Examiner's  
Use*

3 Calcium carbonate,  $\text{CaCO}_3$ , is the raw material used in the manufacture of lime,  $\text{CaO}$ .

(a) (i) Describe how lime is manufactured from calcium carbonate.

..... [1]

(ii) Write a symbol equation for this reaction.

[1]

(iii) State one large scale use of lime.

..... [1]

(b) A student investigated the speed of reaction of calcium carbonate with hydrochloric acid using the apparatus shown below.

(i) Complete the labelling of the apparatus by filling in the three boxes. [3]

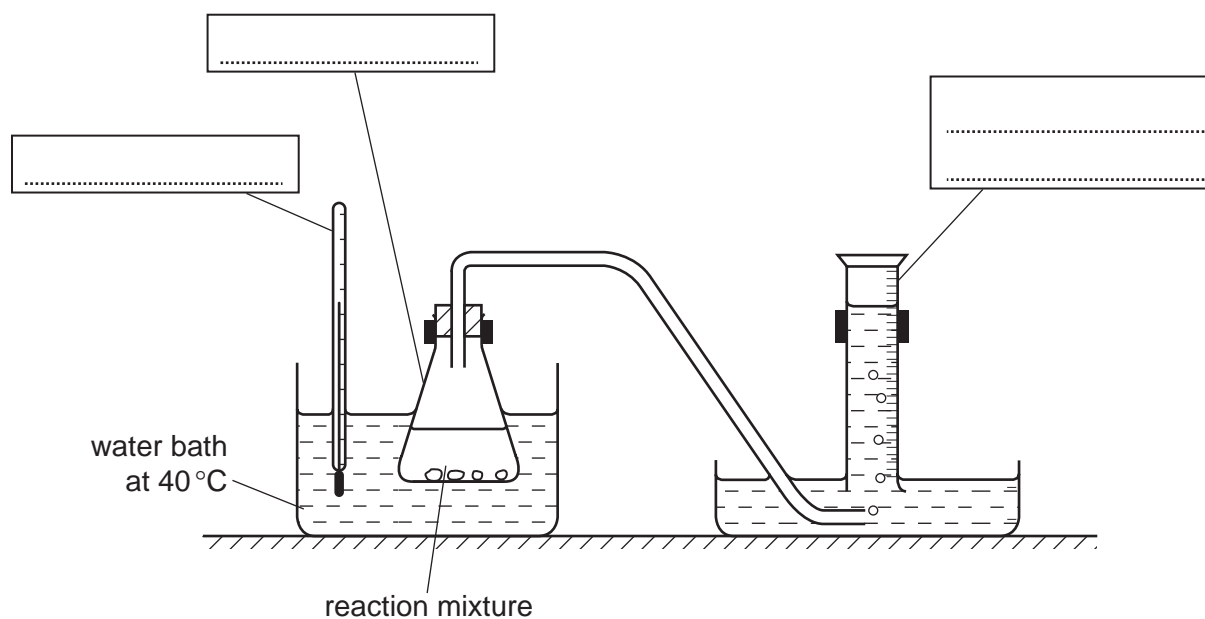

(ii) The equation for the reaction is



Write the word equation for this reaction.

[2]

- (iii) The student carried out the reaction at 40°C using large pieces of calcium carbonate. The results of the experiment are shown below.

For  
Examiner's  
Use

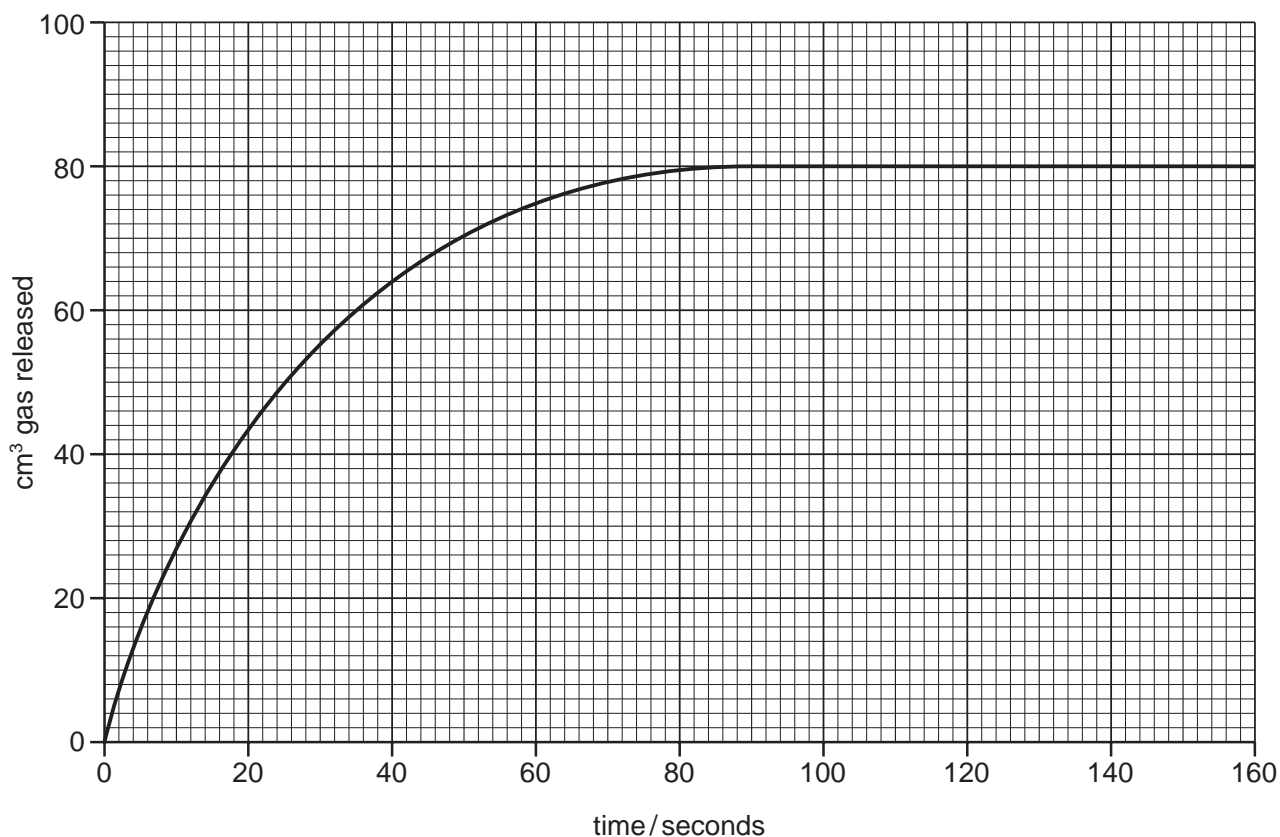

At what time did the reaction stop?

..... [1]

- (iv) The student repeated the experiment using the same mass of powdered calcium carbonate. All other conditions were kept the same. On the grid above, sketch the graph for the reaction with calcium carbonate powder. [2]

- (v) How does the speed of reaction change when

the concentration of hydrochloric acid is decreased, .....

the temperature is increased? ..... [2]

[Total: 13]

4 Iron is extracted from its ore in a blast furnace.

(a) State the name of the ore from which iron is extracted.

..... [1]

(b) The diagram shows a blast furnace.

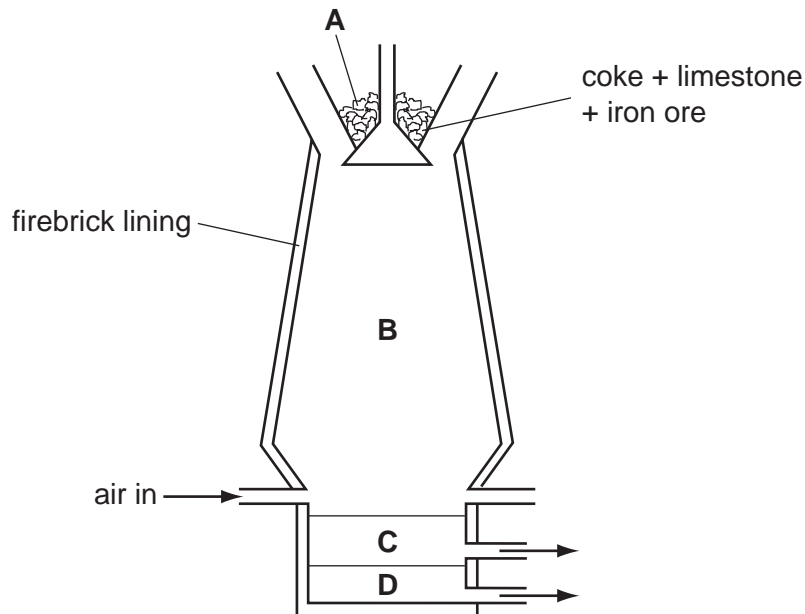

(i) Which **one** of the raw materials is added to the blast furnace to help remove the impurities from the iron ore?

..... [1]

(ii) The impurities are removed as a slag. Which letter on the diagram shows the slag?

..... [1]

(c) Carbon monoxide is formed in the blast furnace by reaction of coke with oxygen.

(i) Complete the equation for this reaction.



(ii) State the adverse affect of carbon monoxide on human health.

..... [1]



(d) In the hottest regions of the blast furnace the following reaction takes place.



Which two of these sentences correctly describe this reaction?  
Tick **two** boxes.

The iron oxide gets reduced.

The reaction is a thermal decomposition.

The carbon gets oxidised.

The carbon gets reduced.

Carbon neutralises the iron oxide.

[1]

(e) Aluminium cannot be extracted from aluminium oxide in a blast furnace.

Explain why aluminium cannot be extracted in this way.

.....

..... [2]

(f) (i) State the name of the method used to extract aluminium from its oxide ore.

..... [1]

(ii) State one use of aluminium.

..... [1]

[Total: 11]

For  
Examiner's  
Use

- 5 The apparatus shown below can be used to measure the energy released when a liquid fuel is burnt. The amount of energy released is calculated from the increase in temperature of a known amount of water.

For  
Examiner's  
Use

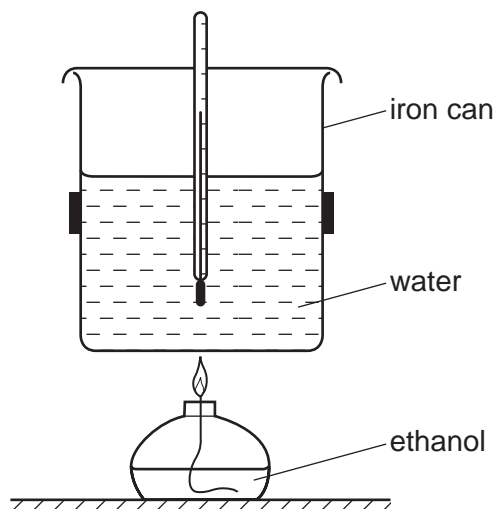

- (a) (i) Explain how this experiment shows that the burning of ethanol is an exothermic reaction.

..... [1]

- (ii) Complete the word equation for the complete combustion of ethanol.

ethanol + oxygen  $\rightarrow$  ..... + ..... [2]

- (b) Ethanol is a fuel containing carbon.  
State the names of two other commonly used fuels containing carbon.

..... and ..... [2]

- (c) Give the formula of the functional group present in ethanol.

..... [1]

- (d) The can contains water. Describe a chemical test for water.

test .....

result ..... [2]

(e) The iron can used in this experiment rusts easily.

For  
Examiner's  
Use

(i) Describe a method which can be used to prevent iron from rusting.

..... [1]

(ii) Rust contains hydrated iron(III) oxide.  
What do you understand by the term *hydrated*?

..... [1]

(iii) Iron is a transition metal.  
State **two** properties which are typical of transition metals.

.....  
..... [2]

[Total: 12]

- 6 The compound shown below is the first member of the alkane homologous series.

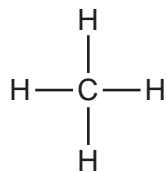

For  
Examiner's  
Use

- (a) State **two** characteristics of a homologous series.

.....  
..... [2]

- (b) Name and draw the structure of the next member of the alkane homologous series.

name .....

structure

[2]

- (c) Complete the table to show the structure and uses of some organic compounds.

name of compound	molecular formula	structure (showing all atoms and bonds)	use
ethene	$\text{C}_2\text{H}_4$		
ethanoic acid	$\text{C}_2\text{H}_4\text{O}_2$		making esters
dibromoethane		$\begin{array}{c} \text{Br} \quad \text{Br} \\   \quad   \\ \text{H}-\text{C}-\text{C}-\text{H} \\   \quad   \\ \text{H} \quad \text{H} \end{array}$	
	$\text{CH}_4$	$\begin{array}{c} \text{H} \\   \\ \text{H}-\text{C}-\text{H} \\   \\ \text{H} \end{array}$	

[6]

(d) Calculate the relative molecular mass of dibromoethane.

*For  
Examiner's  
Use*

[1]

[Total: 11]

7 The diagram shows the structures of calcium chloride, calcium and chlorine.

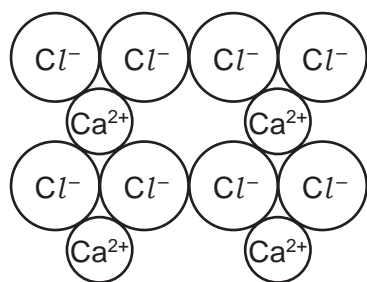

calcium chloride

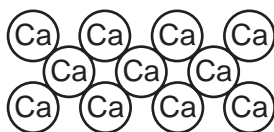

calcium

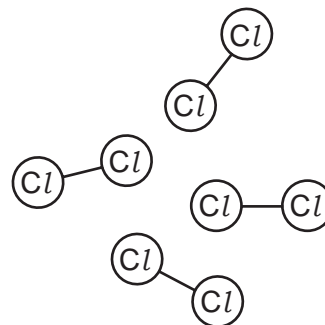

chlorine

For  
Examiner's  
Use

(a) Use ideas about structure and bonding to explain the following:

(i) Calcium chloride conducts electricity when molten but not when solid.

.....  
 .....  
 ..... [2]

(ii) At room temperature, calcium is a solid but chlorine is a gas.

.....  
 .....  
 ..... [2]

(b) Calcium is manufactured by the electrolysis of molten calcium chloride.

For  
Examiner's  
Use

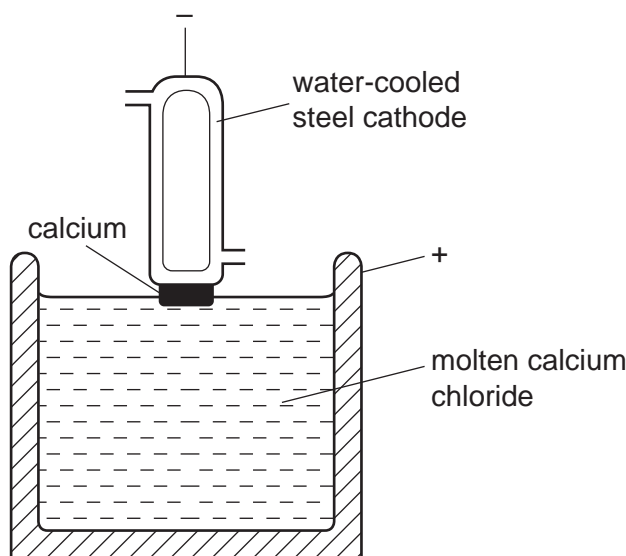

(i) State the products formed  
 at the anode, .....  
 at the cathode. .... [2]

(ii) Suggest a non-metal that can be used as an anode in this electrolysis.  
 ..... [1]

(iii) A stream of inert gas is blown over the calcium as it is removed from the molten calcium chloride.  
 Suggest why a stream of inert gas is blown over the hot calcium.  
 ..... [1]

(iv) State the name of a gas which is inert.  
 ..... [1]

(c) Aqueous sodium hydroxide or aqueous ammonia can be used to test for calcium ions in solution.  
 Describe the results of these tests

with aqueous sodium hydroxide, .....  
 ..... [2]

with aqueous ammonia. ....  
 ..... [1]

[Total: 12]

