



UNIVERSITY OF CAMBRIDGE INTERNATIONAL EXAMINATIONS
International General Certificate of Secondary Education

CANDIDATE
NAME

CENTRE
NUMBER

--	--	--	--	--

CANDIDATE
NUMBER

--	--	--	--

* 0 2 5 2 8 4 4 2 7 6 *

CAMBRIDGE INTERNATIONAL MATHEMATICS

0607/31

Paper 3 (Core)

May/June 2012

1 hour 45 minutes

Candidates answer on the Question Paper

Additional Materials: Geometrical Instruments
 Graphics Calculator

READ THESE INSTRUCTIONS FIRST

Write your Centre number, candidate number and name on all the work you hand in.

Write in dark blue or black pen.

Do not use staples, paper clips, highlighters, glue or correction fluid.

You may use a pencil for any diagrams or graphs.

DO NOT WRITE IN ANY BARCODES.

Answer **all** the questions.

Unless instructed otherwise, give your answers exactly or correct to three significant figures as appropriate.

Answers in degrees should be given to one decimal place.

For π , use your calculator value.

You must show all the relevant working to gain full marks and you will be given marks for correct methods, including sketches, even if your answer is incorrect.

The number of marks is given in brackets [] at the end of each question or part question.

The total number of marks for this paper is 96.

For Examiner's Use

--

This document consists of **18** printed pages and **2** blank pages.



Formula List

Area, A , of triangle, base b , height h .	$A = \frac{1}{2}bh$
Area, A , of circle, radius r .	$A = \pi r^2$
Circumference, C , of circle, radius r .	$C = 2\pi r$
Curved surface area, A , of cylinder of radius r , height h .	$A = 2\pi rh$
Curved surface area, A , of cone of radius r , sloping edge l .	$A = \pi rl$
Curved surface area, A , of sphere of radius r .	$A = 4\pi r^2$
Volume, V , of prism, cross-sectional area A , length l .	$V = Al$
Volume, V , of pyramid, base area A , height h .	$V = \frac{1}{3}Ah$
Volume, V , of cylinder of radius r , height h .	$V = \pi r^2 h$
Volume, V , of cone of radius r , height h .	$V = \frac{1}{3}\pi r^2 h$
Volume, V , of sphere of radius r .	$V = \frac{4}{3}\pi r^3$

Answer **all** the questions.

For
Examiner's
Use

- 1 Some information about 20 students is shown in the Venn diagram.
Each student is represented by a letter.

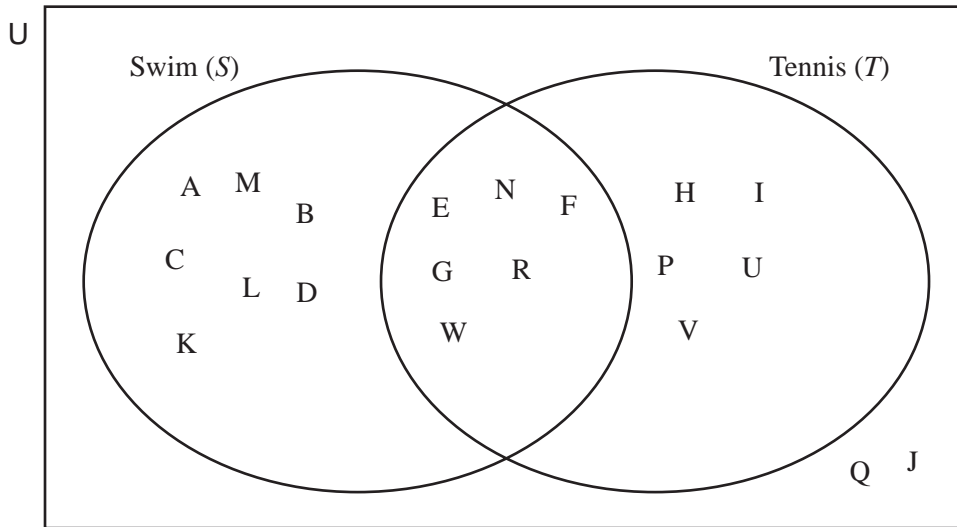

- (a) List the students who swim only.

Answer(a) [1]

- (b) Write down $n(S \cap T)$.

Answer(b) [1]

- (c) Calculate the percentage of the 20 students who do not swim and do not play tennis.

Answer(c) % [2]

- (d) One of the 20 students is chosen at random.

Find the probability that the student plays tennis but does not swim.

Answer(d) [1]

- (e) A student is chosen at random from those students who swim.

Find the probability that this student also plays tennis.

Answer(e) [1]

2 Mrs Edge, Mr Ray and Dr Surd teach mathematics at Imbright Academy.

They spend \$7000 on equipment in the ratio

$$\text{Mrs Edge} : \text{Mr Ray} : \text{Dr Surd} = 33 : 35 : 32 .$$

(a) (i) Show that Mrs Edge spends \$2310.

[2]

(ii) Work out how much Mr Ray and Dr Surd spend.

Answer(a)(ii) Mr Ray \$

Dr Surd \$ [2]

(b) Mrs Edge spends all her \$2310 on 22 calculators.

Find the cost of one calculator.

Answer(b) \$ [1]

(c) Dr Surd buys a laptop computer for her class.
The laptop costs \$1320.

Find how much Dr Surd has left to spend.

Answer(c) \$ [1]

(d) Mr Ray spends 70% of his money on text books.

Find how much Mr Ray spends on text books.

Answer(d) \$ [2]

- 3 (a) Solve the simultaneous equations $x + 5y = 9$ and $3x + 2y = 1$.
Show all your working.

For
Examiner's
Use

Answer(a) $x =$
 $y =$ [3]

- (b) (i) Factorise completely.

$$2\pi r^2 + 2\pi r h$$

Answer(b)(i) [2]

- (ii) Make h the subject of this formula.

$$S = 2\pi r^2 + 2\pi r h$$

Answer(b)(ii) $h =$ [2]

- (c) Simplify.

$$3x \times 2x^2$$

Answer(c) [2]

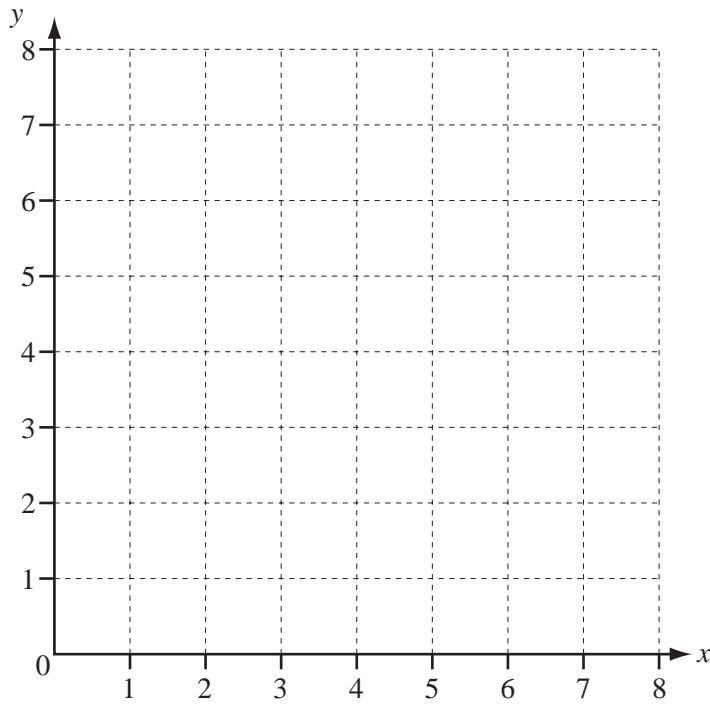

(a) On the grid, plot the points $P(2, 3)$ and $R(4, 7)$. [2]

(b) Draw the straight line PR .

Find the co-ordinates of M , the midpoint of PR .

Answer(b) (..... ,) [1]

(c) Write \vec{PR} in component form.

Answer(c) $\left(\begin{array}{c} \\ \end{array} \right)$ [1]

(d) Calculate the gradient of PR .

Answer(d) [2]

- (e) Write down the gradient of a line parallel to PR .

Answer(e) [1]

- (f) Find the equation of the straight line through the point $(5, 3)$ which is parallel to PR .

Answer(f) [2]

*For
Examiner's
Use*

5

For
Examiner's
Use

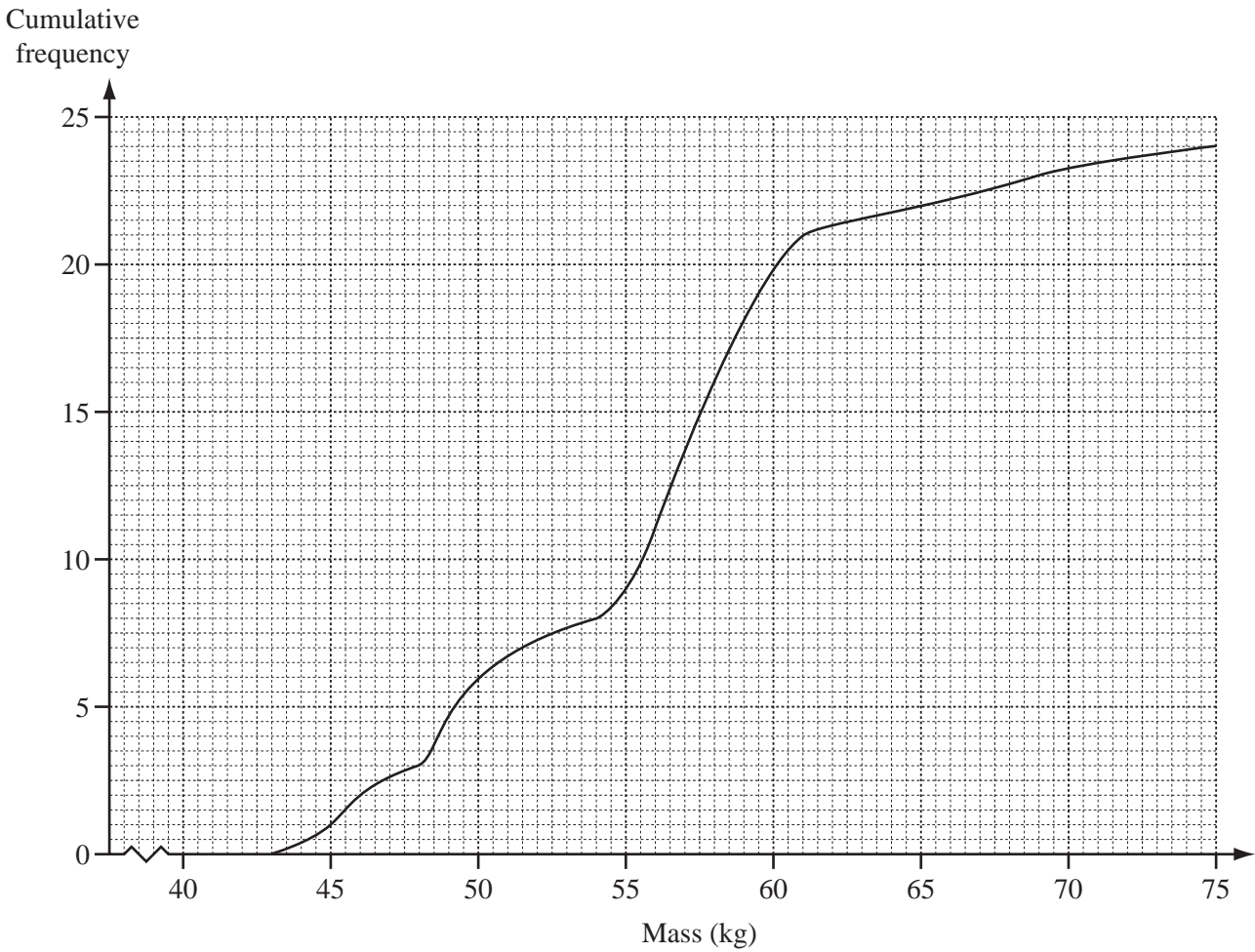

All the members of a Zumba club were weighed and their masses recorded. The results are shown on the cumulative frequency graph.

(a) Find

(i) the number of members in the Zumba club,

Answer(a)(i) [1]

(ii) the median,

Answer(a)(ii) kg [1]

(iii) the inter-quartile range.

Answer(a)(iii) kg [2]

(b) A member of the Zumba club is selected at random.

Find the probability that this member has a mass less than 55kg.

Answer(b) [2]

6 (a)

For
Examiner's
Use

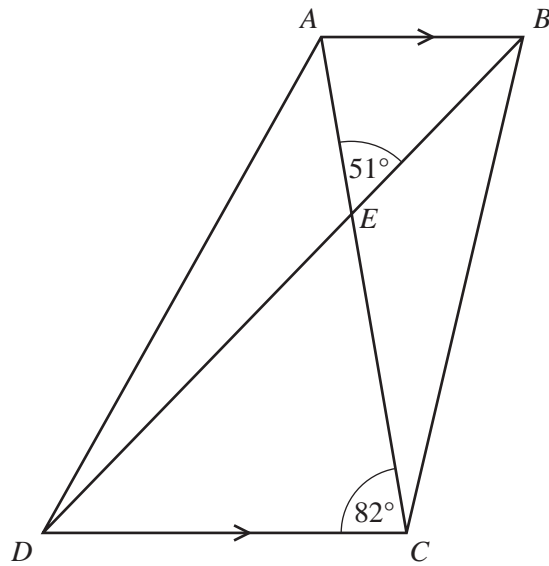

NOT TO
SCALE

AC and DB are the diagonals of the quadrilateral $ABCD$.
 AB is parallel to DC .
 Angle $DCE = 82^\circ$ and angle $AEB = 51^\circ$.

(i) Write down the mathematical name for the quadrilateral $ABCD$.

Answer(a)(i) [1]

(ii) Find angle DEC .

Answer(a)(ii) [1]

(iii) Find angle EAB .

Answer(a)(iii) [1]

(iv) Find angle AED .

Answer(a)(iv) [1]

(b) Calculate the size of one interior angle of a regular pentagon.

Answer(b) [3]

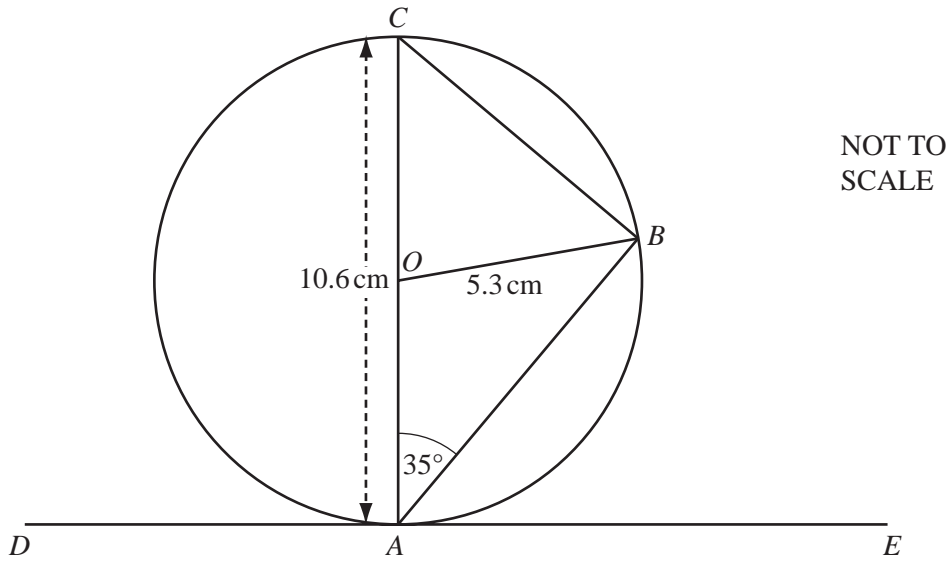

DE is a tangent at A to the circle, centre O , diameter 10.6 cm.
Angle $OAB = 35^\circ$.

(a) Find

(i) angle ABC ,

Answer(a)(i) [1]

(ii) angle CAD ,

Answer(a)(ii) [1]

(iii) angle AOB .

Answer(a)(iii) [1]

(b) Calculate the length of the arc AB .

Answer(b) cm [2]

(c) Use trigonometry to calculate the length of the chord CB .

Answer(c) cm [2]

8

For
Examiner's
Use

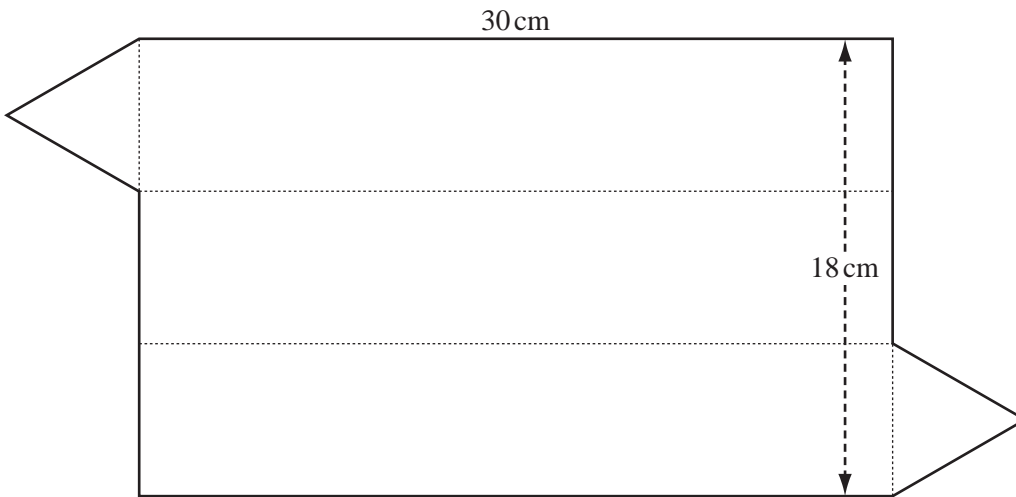

NOT TO
SCALE

The diagram shows the paper used to cover a triangular prism.
The paper is made up of a rectangle, 30 cm by 18 cm, and two equilateral triangles.

(a) Find

(i) the length of a side of one of the equilateral triangles,

Answer(a)(i) cm [1]

(ii) the total perimeter of the paper.

Answer(a)(ii) cm [2]

(b) The area of each equilateral triangle is 15.6 cm^2 , correct to 3 significant figures.

Calculate the total area of the paper.

Answer(b) cm^2 [2]

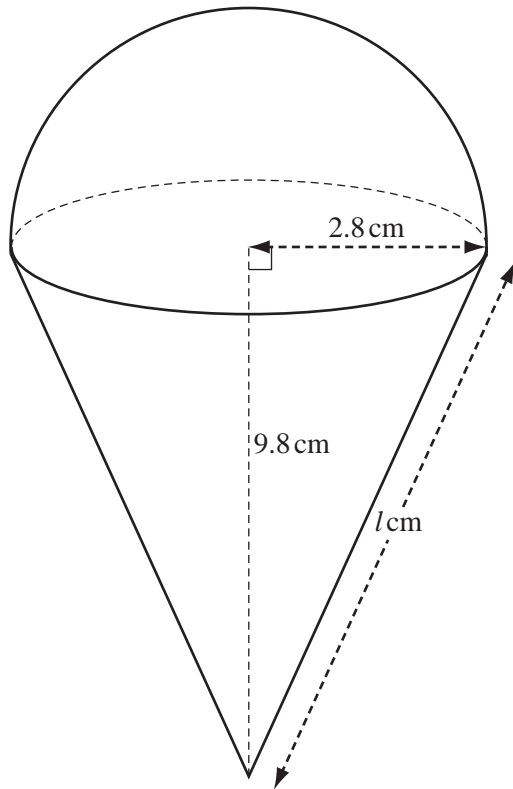

NOT TO
SCALE

The diagram shows an ice cream cornet.
The cornet is made from a cone and a hemisphere.

The cone has a base radius of 2.8 cm and a height of 9.8 cm.
The hemisphere has a radius of 2.8 cm.

(a) Calculate the volume of the hemisphere.

Answer(a) cm³ [2]

(b) The hemisphere is made of ice cream.
The curved surface area of the hemisphere is covered in chocolate.

Calculate the surface area covered in chocolate.

Answer(b) cm² [2]

(c) Calculate the length of the sloping edge, l , of the cone.

For
Examiner's
Use

Answer(c) cm [2]

(d) Calculate the curved surface area of the cone.

Answer(d) cm² [2]

(e) The radius of the hemisphere in a similar ice cream cornet is 2 cm.

Calculate the height of the cone used to make this ice cream cornet.

Answer(e) cm [2]

10 To find some hidden treasure, Zareen is given the following instructions.

From P, walk 200 metres on a bearing of 030° .
Then walk 80 metres on a bearing of 120° .
Here lies the treasure.

For
Examiner's
Use

(a) Show this information on a sketch of Zareen's route to the treasure.

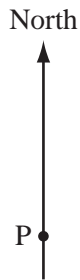

[2]

(b) Use trigonometry to calculate the bearing of the treasure from P.

Answer(b) [4]

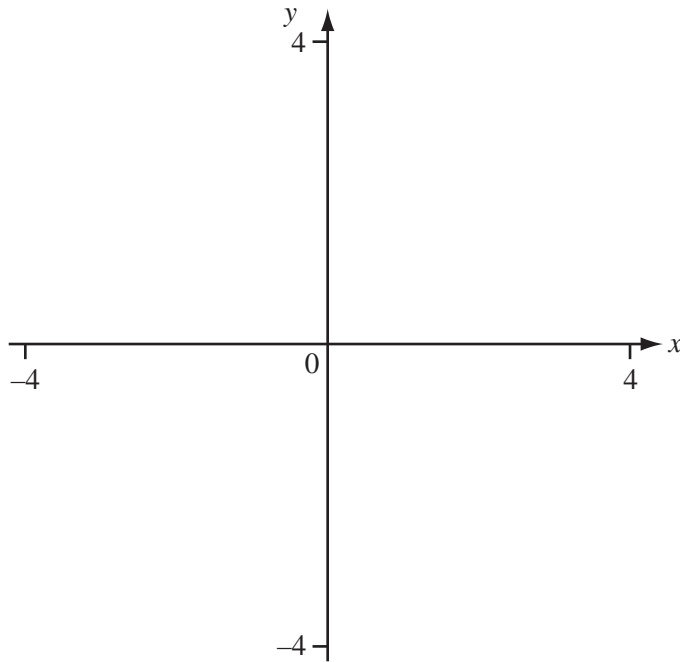

(a) Sketch the graph of $y = 0.1x^3 + 0.15x^2 - 0.6x$ for $-4 \leq x \leq 4$. [3]

(b) Write down the co-ordinates of the local maximum point and the local minimum point.

Answer(b) maximum (..... ,)

minimum (..... ,) [2]

(c) One of the zeros of $y = 0.1x^3 + 0.15x^2 - 0.6x$ is -3.31 .

Write down the other two zeros.

Answer(c) $x = \dots\dots\dots$ and $x = \dots\dots\dots$ [2]

(d) Using the same axes, sketch the graph of

$$y = 0.1x^3 + 0.15x^2 - 0.6x + 3. \quad [1]$$

- 12 The lung capacity of 35 males was measured using a machine. The machine's readings are shown in the table.

For
Examiner's
Use

Lung capacity reading (cm ³)	Frequency
3300	3
3400	1
3500	3
3600	4
3700	3
3800	6
3900	4
4000	3
4100	2
4200	2
4300	3
4400	1

- (a) Calculate the mean lung capacity.

Answer(a) cm³ [1]

- (b) Find the median lung capacity.

Answer(b) cm³ [1]

- (c) Write down the fraction of males with a reading greater than 3800 cm³.
Give your answer in its lowest term.

Answer(c) [2]

(d) The scatter diagram shows the heights and lung capacity readings of the 35 males.

For
Examiner's
Use

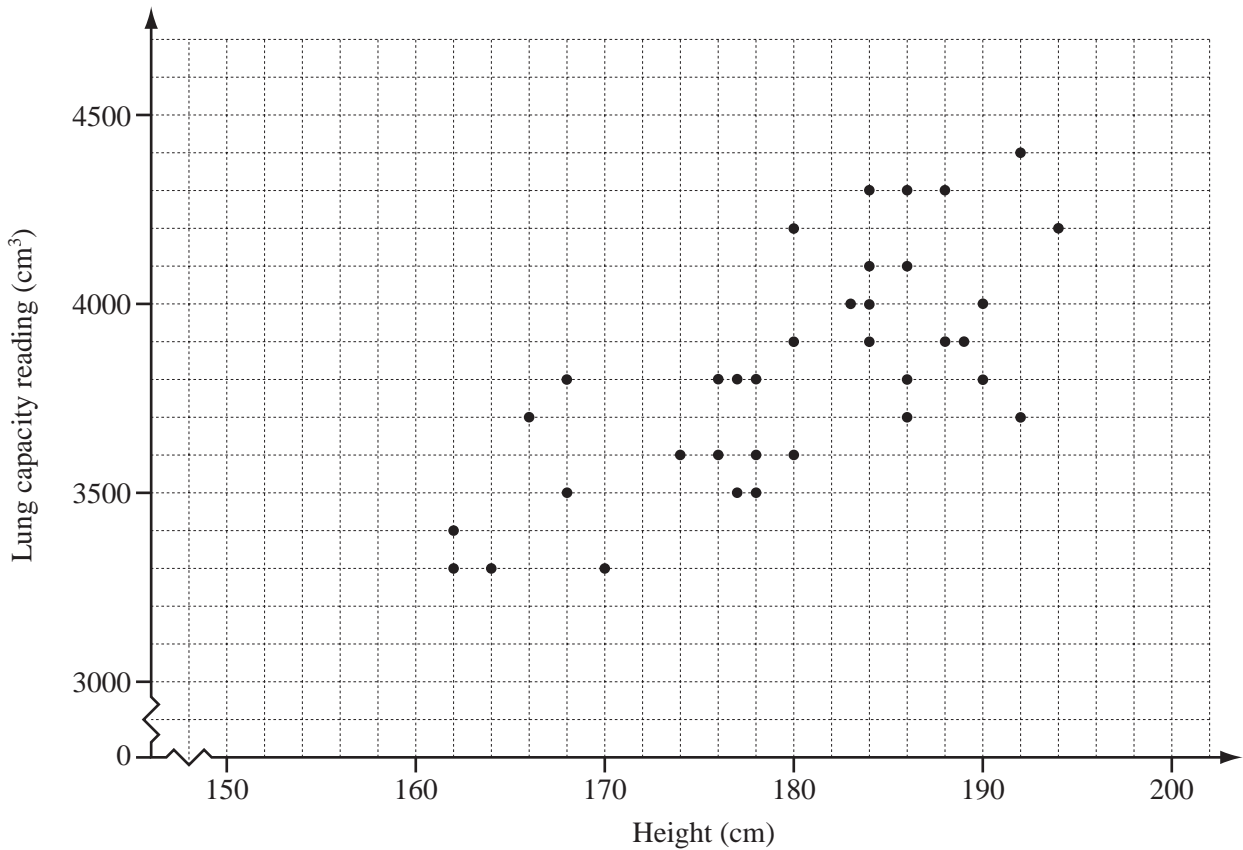

(i) Describe the correlation between height and lung capacity reading.

Answer(d)(i) [1]

(ii) The mean height of the 35 males is 180 cm.

Using your answer to **part (a)**, draw a line of best fit on the diagram. [2]

(iii) Estimate the lung capacity reading for a male of height 165 cm.

Answer(d)(iii) cm³ [1]

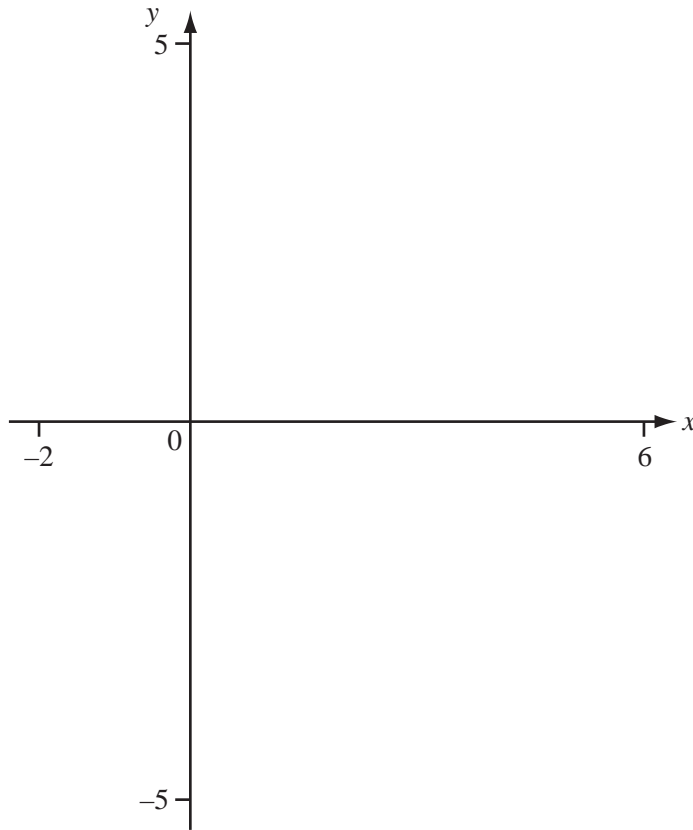

(a) Sketch the graph of $y = \frac{3}{(x-2)}$ for $-2 \leq x \leq 6$. [2]

(b) Write down the equations of the two asymptotes.

Answer(b)

..... [2]

(c) Using the same axes, sketch the line $y = x - 3$. [1]

(d) Write down the co-ordinates of the points of intersection of

$$y = \frac{3}{(x-2)} \text{ and } y = x - 3.$$

Answer(d) (..... ,)

and (..... ,) [2]

BLANK PAGE

BLANK PAGE

Permission to reproduce items where third-party owned material protected by copyright is included has been sought and cleared where possible. Every reasonable effort has been made by the publisher (UCLES) to trace copyright holders, but if any items requiring clearance have unwittingly been included, the publisher will be pleased to make amends at the earliest possible opportunity.

University of Cambridge International Examinations is part of the Cambridge Assessment Group. Cambridge Assessment is the brand name of University of Cambridge Local Examinations Syndicate (UCLES), which is itself a department of the University of Cambridge.