

Centre Number	Candidate Number	Name
---------------	------------------	------

UNIVERSITY OF CAMBRIDGE INTERNATIONAL EXAMINATIONS
International General Certificate of Secondary Education

PHYSICAL SCIENCE

0652/02

Paper 2

May/June 2004

1 hour 15 minutes

Candidates answer on the Question Paper.
No Additional Materials are required.

READ THESE INSTRUCTIONS FIRST

Write your Centre number, candidate number and name on all the work you hand in.
Write in dark blue or black pen in the spaces provided on the Question Paper.
You may use a soft pencil for any diagrams, graphs, tables or rough working.
Do not use staples, paper clips, highlighters, glue or correction fluid.

Answer **all** questions.

At the end of the examination, fasten all your work securely together.

The number of marks is given in brackets [] at the end of each question or part question.

A copy of the Periodic Table is printed on page 16.

FOR EXAMINER'S USE	
1	
2	
3	
4	
5	
6	
7	
8	
9	
10	
11	
12	
13	
14	
Total	

If you have been given a label, look at the details. If any details are incorrect or missing, please fill in your correct details in the space given at the top of this page.

Stick your personal label here, if provided.

This document consists of **16** printed pages.



1 Fig. 1.1(a) shows a spring used in the suspension of a cart.

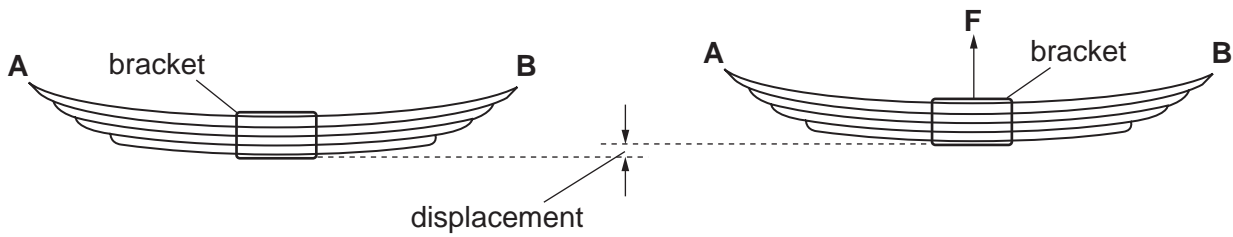

Fig. 1.1(a)

Fig. 1.1(b)

A student supports the ends **A** and **B**. He applies an upward force **F** to the bracket, as shown in Fig. 1.1(b), and records the displacement at the centre of the spring. The table in Fig. 1.2 shows the results.

force / N	displacement / cm
0	0
200	3.0
400	5.9
600	9.1
800	12.0
1000	15.1
1200	18.0

Fig. 1.2

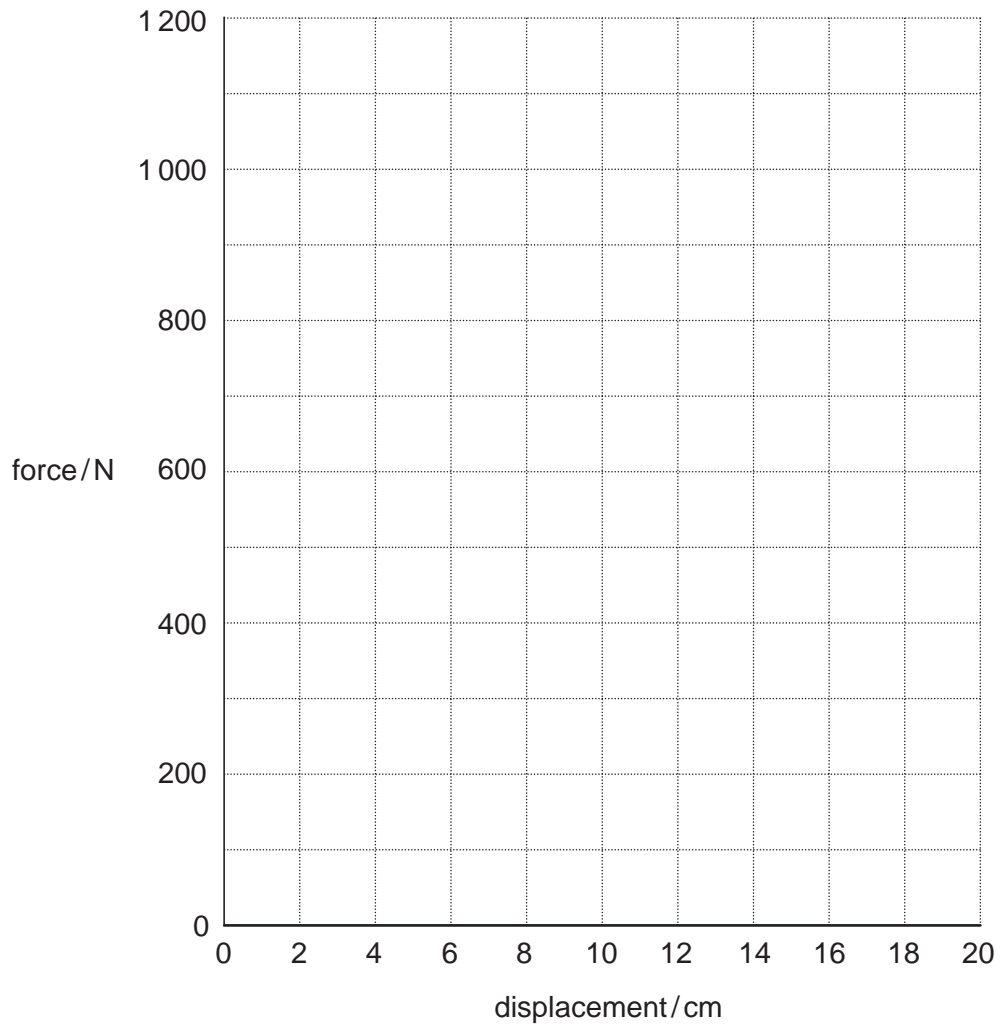
**Fig. 1.3**

(a) Plot a graph of the force against displacement using the grid in Fig. 1.3.

[3]

- (b) The instructions for building a cart state that the spring must not be displaced by more than 0.8 cm nor less than 0.6 cm for every 50 N that is added to the force.

Use the graph to help you to explain whether the spring is suitable.

.....

.....

.....[3]

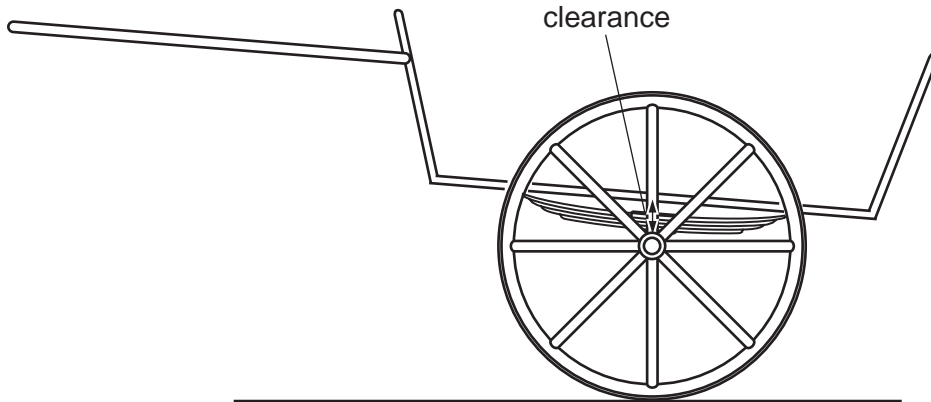

Fig. 1.4

- (c) Fig. 1.4 shows the spring, which supports the axle, attached to the cart.

The maximum displacement that the spring can have is 14 cm.

Use your graph to find this load.

load = N [2]

- 2 (a) Oxygen in the air consists mainly of the isotope $^{16}_8\text{O}$ with some $^{18}_8\text{O}$.

Complete the table for these isotopes.

	$^{16}_8\text{O}$	$^{18}_8\text{O}$
number of protons in nucleus		
number of neutrons in nucleus		
arrangement of electrons in shells in the atom		

[2]

- (b) In terms of covalent bonding, explain how oxygen and hydrogen form a molecule of water, H_2O . Draw a diagram to help your explanation.

.....
 [2]

- 3 (a) Methanol, CH_3OH , burns in excess air to form carbon dioxide and water.

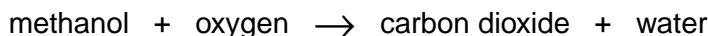

Balance the chemical equation for this reaction.

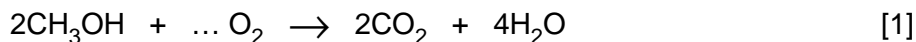

- (b) Use the information in the Periodic Table on page 16 to calculate the relative molecular mass, M_r , of methanol.

Show your working.

$$M_r = \dots \dots \dots [2]$$

- (c) The relative molecular mass for carbon dioxide is greater than for methanol yet carbon dioxide is a gas and methanol a liquid at room temperature.

Suggest a reason for this physical difference.

.....
.....[1]

- 4 (a) Some solids are safe when they are in large lumps, but burn explosively in air when in a fine powder.

Explain why the size of the pieces has this effect.

.....
.....
.....[2]

- (b) Some solids can react explosively when added to an acid.

State how to make these reactions safer by altering

- (i) the concentration of the acid,

.....[1]

- (ii) the temperature of the acid.

.....[1]

- 5 Fig. 5.1 shows an electronic system for locking a safe door. The diagram shows the door in the locked position with the spring pushing the bolt firmly into the wall.

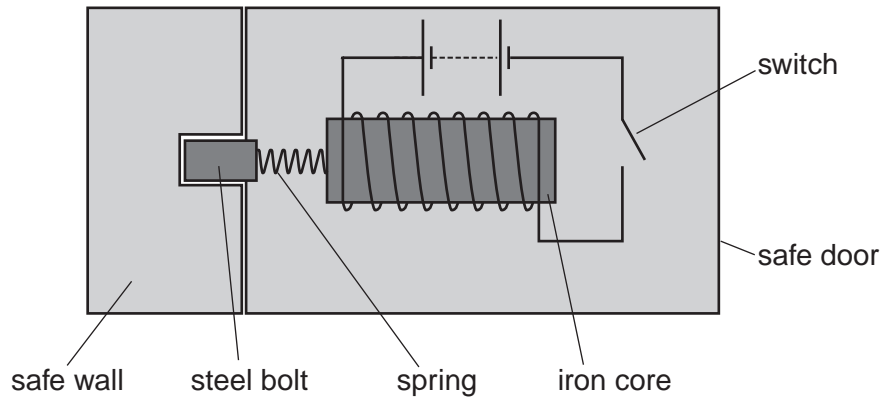

Fig. 5.1

- (a) Explain why the door can be opened when the switch is closed.

.....
[2]

- (b) Explain why iron is a suitable material from which to make the core.

.....
[2]

- (c) A burglar attempts to open the safe by cutting the wires from the battery. Explain why this will **not** work.

.....
[2]

- 6 (a) Steam is condensed to water during a distillation experiment.

Use the kinetic particle theory of matter to explain why energy must be **removed** to condense a gas to form a liquid.

.....

[2]

- (b) Two liquids **P** and **Q** are cooled to form solids. The temperature and time are recorded during each experiment and graphs are plotted, as shown in Fig. 6.1.

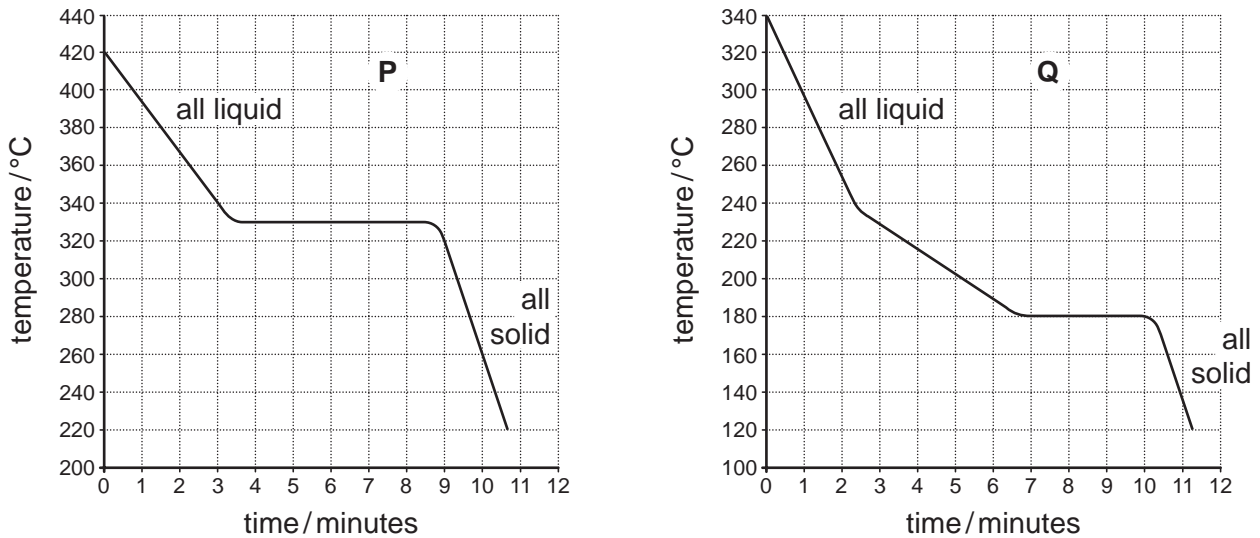

Fig. 6.1

- (i) Use Fig. 6.1 to determine the melting point of **P**. °C [1]
- (ii) Explain how these cooling curves show that **P** is a pure substance and that **Q** is a mixture of substances.

.....

[2]

7 Magnesium reacts slowly with water at room temperature.

Potassium reacts vigorously with water at room temperature.

(a) Explain this difference of reaction in terms of the reactivity series of metals.

.....[1]

(b) The reaction between potassium and water is exothermic and produces an alkaline solution and hydrogen.

(i) Explain the meaning of *exothermic*.

.....[1]

(ii) Describe how to test for the alkaline solution.

test

result[2]

(iii) A student collects some of the hydrogen in a test-tube.

Describe how to test for the hydrogen produced.

test

result[2]

- 8 Fig. 8.1 shows a child's toy aeroplane. The plane is powered by turning the propeller to twist a rubber band.

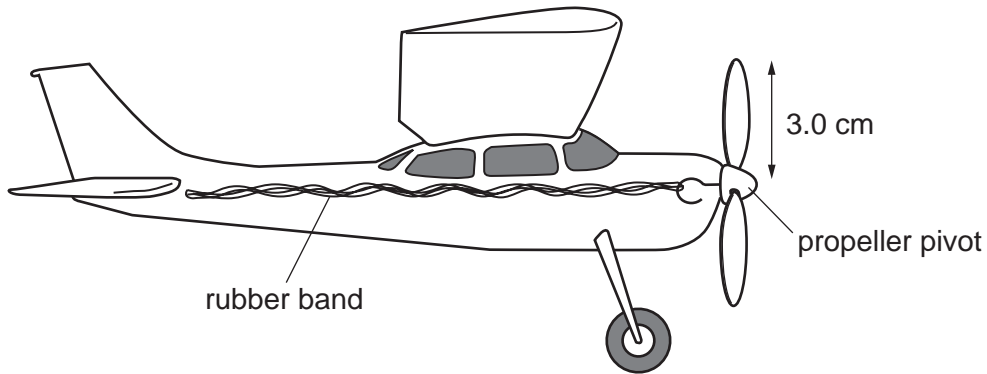

Fig. 8.1

- (a) Complete the sentences below.

The twisted rubber band has energy. This is converted into mainly energy as it begins to untwist and turn the propeller, although some is lost to the surroundings as waste energy. To wind the rubber band up again the child must do in twisting it. [4]

- (b) The child has to apply a perpendicular force of 2.5 N at 3 cm from the propeller pivot in order to turn the propeller.

Calculate the moment of this force about the pivot. Show your working and include the unit.

moment = [3]

- (c) When the child releases the aeroplane it travels a distance of 48 m in 16 s.

Calculate the average speed at which the aeroplane travelled. Show your working and include the unit.

speed = [3]

9 Common pollutants in the air are carbon monoxide and sulphur dioxide.

(a) Explain why carbon monoxide can have an adverse effect on human health.

.....
.....
.....[2]

(b) Explain why sulphur dioxide can have an adverse effect on buildings.

.....
.....
.....[2]

10 (a) Draw the structures of ethanol, C_2H_6O , and ethanoic acid, $C_2H_4O_2$.

ethanol

ethanoic acid

[4]

(b) State two uses of ethanol.

1

2[2]

- 11 Fig. 11.1 shows a circuit which could be used to investigate the current-voltage characteristics of a metallic wire.

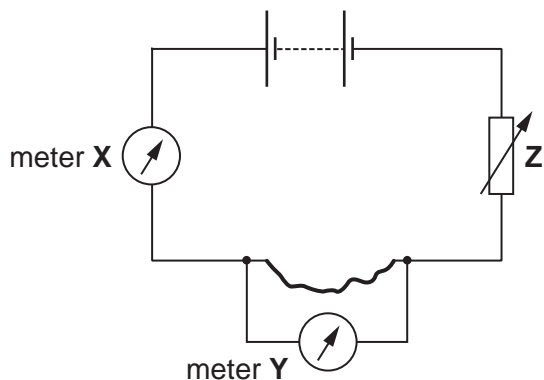

Fig. 11.1

- (a) Name the components X, Y and Z.

X

Y

Z

[3]

- (b) Explain the purpose of component Z.

.....

.....[2]

- (c) On the axes in Fig. 11.2 complete the graph to show the characteristics of a metallic conductor.

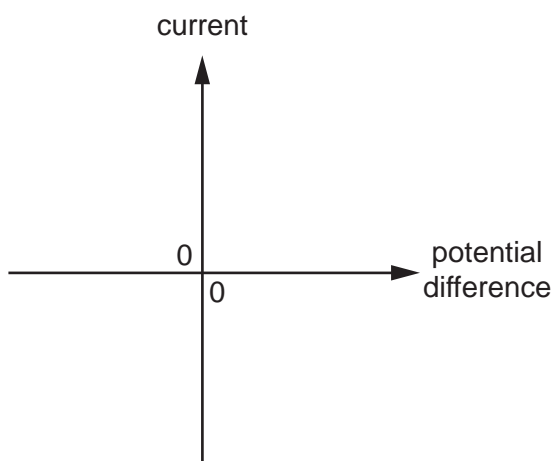

Fig. 11.2

[2]

- 12 A student adds a small quantity of a solid oxide to water in a test-tube. She tests the solution produced with Universal Indicator paper. The pH is 3.

Use words from the list below to complete the following sentences.

acidic basic left metal non-metal right

The type of oxide used in this experiment is The element forming this oxide is a This element is likely to be found on the of the Periodic Table. [3]

- 13 The tungsten wire in a lamp bulb is heated electrically to such a high temperature that it emits light.

(a) Explain why the bulb is filled with argon.

.....

[2]

(b) The atomic number of tungsten is 74, its density is 19 g/cm³ and its melting point is 3400 °C.

How does this information support the fact that tungsten is a **transition** element?

.....

[2]

14 Fig. 14.1 shows a tube used to demonstrate thermionic emission.

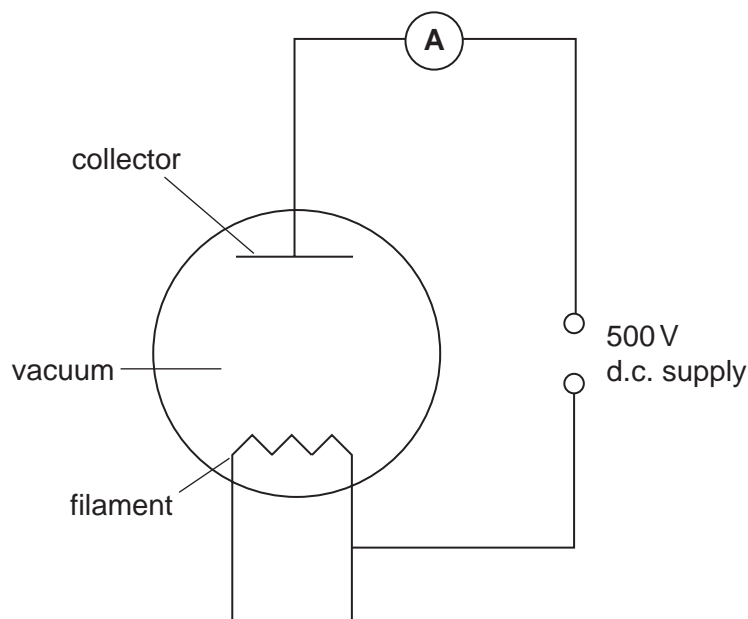

Fig. 14.1

The reading on the ammeter is zero when the collector electrode is negative, and 4.8 mA when the collector is positive.

- (a) (i) State with a reason whether the charges emitted from the filament are positive or negative.

.....

- (ii) Name the particles that are emitted.

.....

[3]

Fig. 14.2 shows the outline of a cathode ray tube.

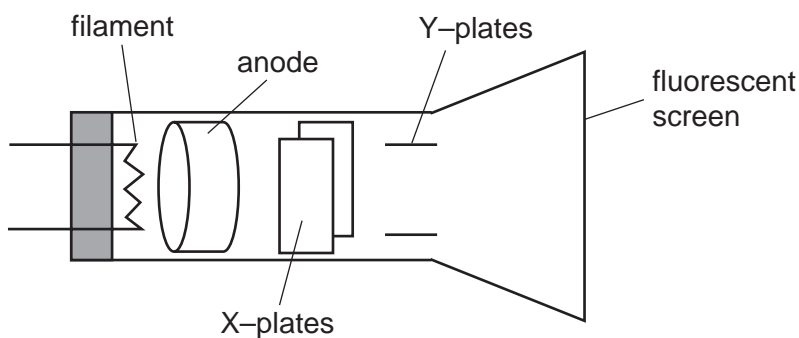

Fig. 14.2

(b) Explain the purpose of the X-plates and the Y-plates.

X-plates

.....

Y-plates

.....[3]

(c) Fig. 14.3(i) shows the screen of the cathode ray tube being used to display a waveform.

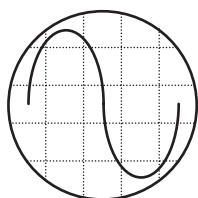

Fig. 14.3(i)

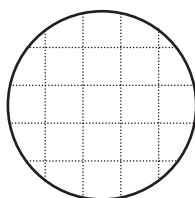

Fig. 14.3(ii)

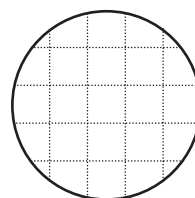

Fig. 14.3(iii)

- (i)** On Fig. 14.3(ii) draw a wave of the same frequency as Fig. 14.3(i) but of smaller amplitude.
- (ii)** On Fig. 14.3(iii) draw a wave of the same amplitude as Fig. 14.3(i) but of greater frequency.

[3]

DATA SHEET
The Periodic Table of the Elements

		Group												
I	II	III	IV	V	VI	VII	0							
		1 H Hydrogen 1												
7 Li Lithium 3	9 Be Beryllium 4		11 B Boron 5	12 C Carbon 6	14 N Nitrogen 7	16 O Oxygen 8	19 F Fluorine 9	20 Ne Neon 10						
23 Na Sodium 11	24 Mg Magnesium 12		27 Al Aluminium 13	28 Si Silicon 14	31 P Phosphorus 15	32 S Sulphur 16	35.5 Cl Chlorine 17	40 Ar Argon 18						
39 K Potassium 19	40 Ca Calcium 20		70 Ga Gallium 31	73 Ge Germanium 32	75 As Arsenic 33	79 Se Selenium 34	80 Br Bromine 35	84 Kr Krypton 36						
85 Rb Rubidium 37	88 Sr Strontium 38		115 In Indium 49	112 Cd Cadmium 48	119 Sn Tin 50	122 Sb Antimony 51	127 I Iodine 53	131 Xe Xenon 54						
133 Cs Caesium 55	137 Ba Barium 56		204 Tl Thallium 81	201 Hg Mercury 80	207 Pb Lead 82	209 Bi Bismuth 83	210 Po Polonium 84	210 Rn Radon 86						
226 Ra Radium 88	227 Ac Actinium 89													
* 58-71 Lanthanoid series														
† 90-103 Actinoid series														
<table style="width: 100%; border-collapse: collapse;"> <tr> <td style="border: 1px solid black; width: 20px; text-align: center;">a</td> <td style="border: 1px solid black; width: 20px; text-align: center;">X</td> <td style="border: 1px solid black; width: 20px; text-align: center;">b</td> </tr> </table> <p>a = relative atomic mass X = atomic symbol b = proton (atomic) number</p>												a	X	b
a	X	b												
140 Ce Cerium 58	141 Pr Praseodymium 59	144 Nd Neodymium 60	150 Sm Samarium 62	152 Eu Europium 63	157 Gd Gadolinium 64	159 Tb Terbium 65	162 Dy Dysprosium 66	165 Ho Holmium 67	167 Er Erbium 68	169 Tm Thulium 69	173 Yb Ytterbium 70	175 Lu Lutetium 71		
232 Th Thorium 90	238 Pa Protactinium 91	238 U Uranium 92	244 Pu Plutonium 94	247 Am Americium 95	251 Cm Curium 96	259 Bk Berkelium 97	261 Cf Californium 98	265 Es Einsteinium 99	267 Fm Fermium 100	271 Md Mendelevium 101	277 No Nobelium 102	289 Lr Lawrencium 103		

The volume of one mole of any gas is 24 dm³ at room temperature and pressure (r.t.p.).