

Centre Number	Candidate Number	Name
---------------	------------------	------

UNIVERSITY OF CAMBRIDGE INTERNATIONAL EXAMINATIONS
International General Certificate of Secondary Education

PHYSICAL SCIENCE

0652/06

Paper 6 Alternative to Practical

October/November 2006

1 hour

Candidates answer on the Question Paper.
No Additional Materials are required.

READ THESE INSTRUCTIONS FIRST

Write your Centre number, candidate number and name on all the work you hand in.

Write in dark blue or black pen.

You may use a soft pencil for any diagrams or graphs.

Do not use staples, paper clips, highlighters, glue or correction fluid.

Answer **all** questions.

At the end of the examination, fasten all your work securely together.

The number of marks is given in brackets [] at the end of each question or part question.

For Examiner's Use	
1	
2	
3	
4	
5	
6	
Total	

This document consists of **19** printed pages and **1** blank page.



- 1 A student is given a sample of powdered limestone. The student is asked to find out the amount of calcium carbonate in the sample, which also has sand in it as an impurity. He is given some dilute hydrochloric acid. He is told that 1 g of calcium carbonate will react exactly with 10.0 cm^3 of the hydrochloric acid.

- (a) (i) A gas is given off when calcium carbonate reacts with hydrochloric acid.

Name this gas.

..... [1]

- (ii) State a test for this gas and the result that you would expect.

.....
..... [1]

The student weighs out a sample of the limestone into a beaker. Fig. 1.1 shows the balance readings.

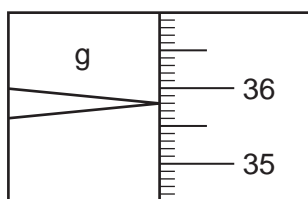

mass of beaker

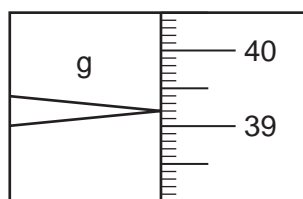

mass of beaker + limestone

Fig. 1.1

- (b) (i) Read the balance windows and record the readings in the spaces below.

mass of beaker + limestone = g

mass of beaker = g [2]

- (ii) Calculate the mass of limestone.

mass of limestone = g [1]

The student carefully adds hydrochloric acid from a burette, a few drops at a time, to the powdered limestone.

- (c) How can the student decide when he has added enough acid to dissolve all the calcium carbonate in the sample of limestone?

.....
 [1]

Fig. 1.2 shows the scale of the burette before and after the addition of the hydrochloric acid.

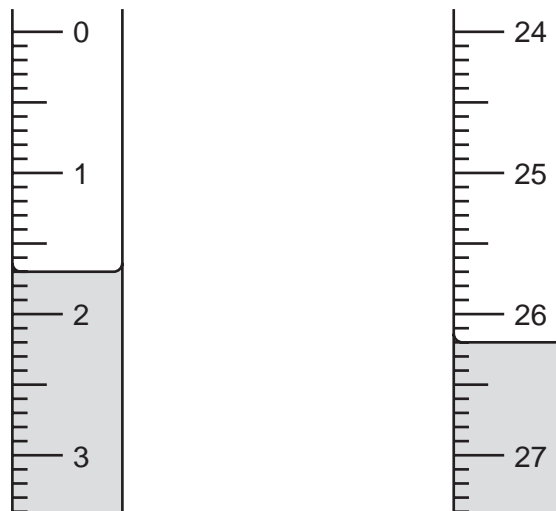

Fig. 1.2

- (d) (i) Record the burette readings in the spaces below.

second reading cm³
 first reading cm³ [2]

- (ii) Calculate the volume of hydrochloric acid added.

volume of acid added = cm³ [1]

The volume of the hydrochloric acid that reacts with 1 g of calcium carbonate is 10 cm³.

- (e) Use the result from (d)(ii) to calculate the mass of calcium carbonate in the sample of limestone.

mass of calcium carbonate = g [1]

- 2 A student did an experiment with an L-shaped piece of card. He wanted to find its centre of mass. You do not need to know the meaning of the term *centre of mass*.
- The card was suspended on a pin pushed through a hole 5 mm from point **A** (distance x). A plumb-line was also hung on the pin.

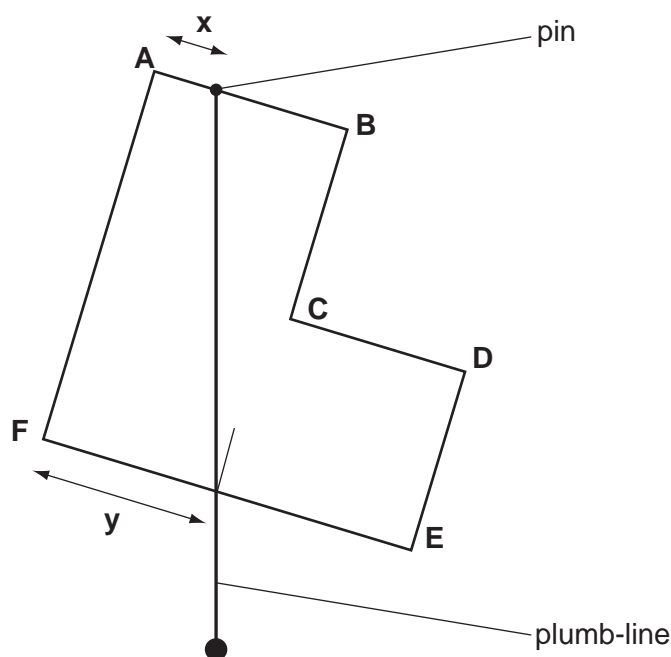

Fig. 2.1

- When he was sure that the card was hanging freely, he marked the point at which the plumb-line crossed line **FE** (distance y from **F**).
- He recorded the distances x and y in Fig. 2.2.
- He moved the position of the pin towards **B** and repeated the experiment until he had obtained 5 sets of readings.

reading number	1	2	3	4	5
x/mm	5			20	25
y/mm	67			57	53

Fig. 2.2

- (a) Figs. 2.3 and 2.4 show distances x and y for the two missing readings. Measure the distances x and y and record them in Fig. 2.2. [4]

reading 2

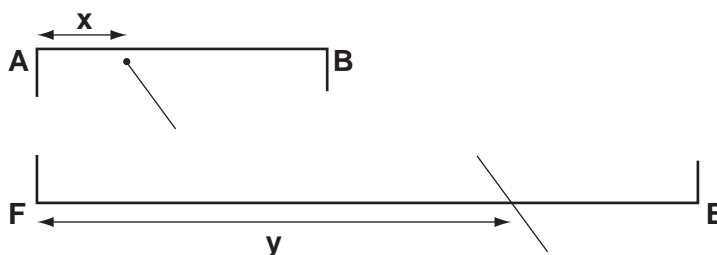

Fig. 2.3

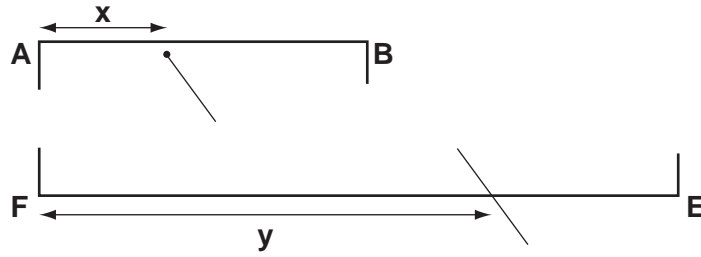
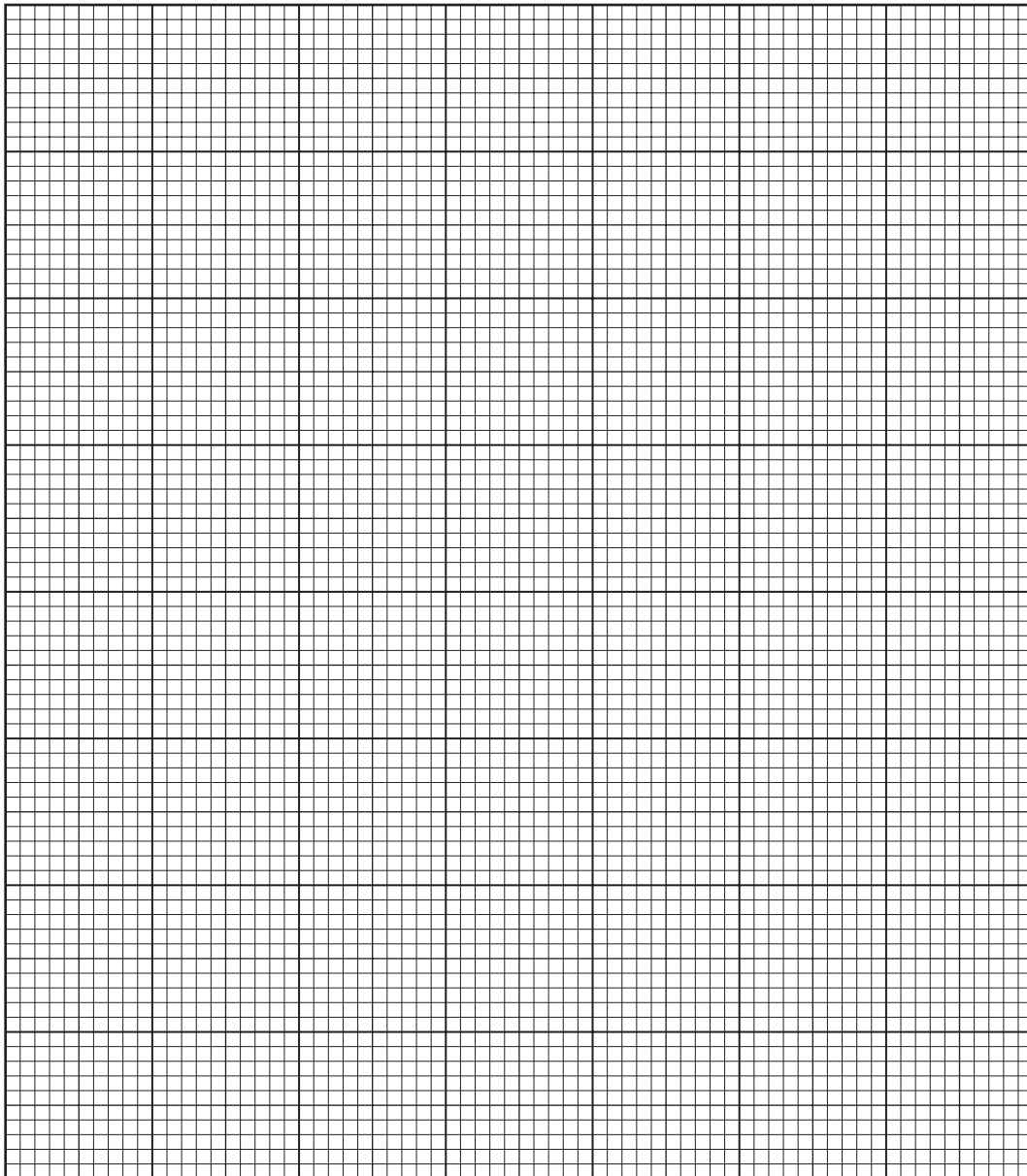

Fig. 2.4

- (b) (i) Plot a graph of y (vertical axis) against x and draw the best fit straight line. Extend the line to cut the vertical axis. [3]



- (ii) From the graph determine y_0 , the value of y when $x = 0$.

$y_0 = \dots\dots\dots$ mm [1]

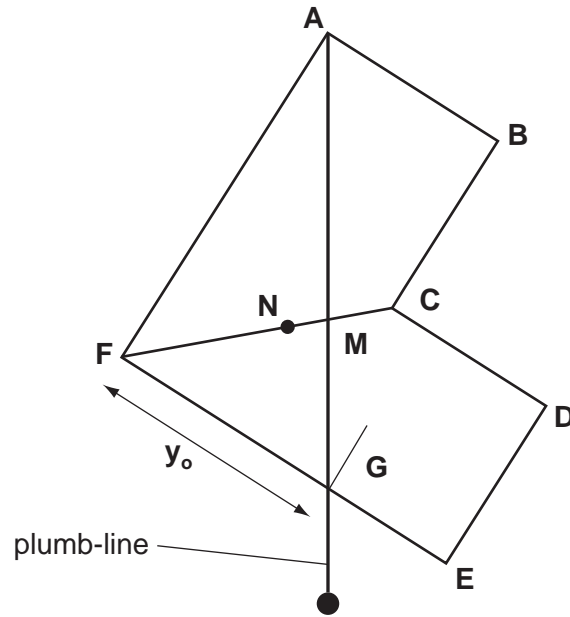

Fig. 2.5

- (iii) Use the value of y_0 from (ii) to mark, on Fig. 2.6, the position of the plumb-line AG . (See Fig. 2.5)
Label point M , where AG crosses FC . [1]

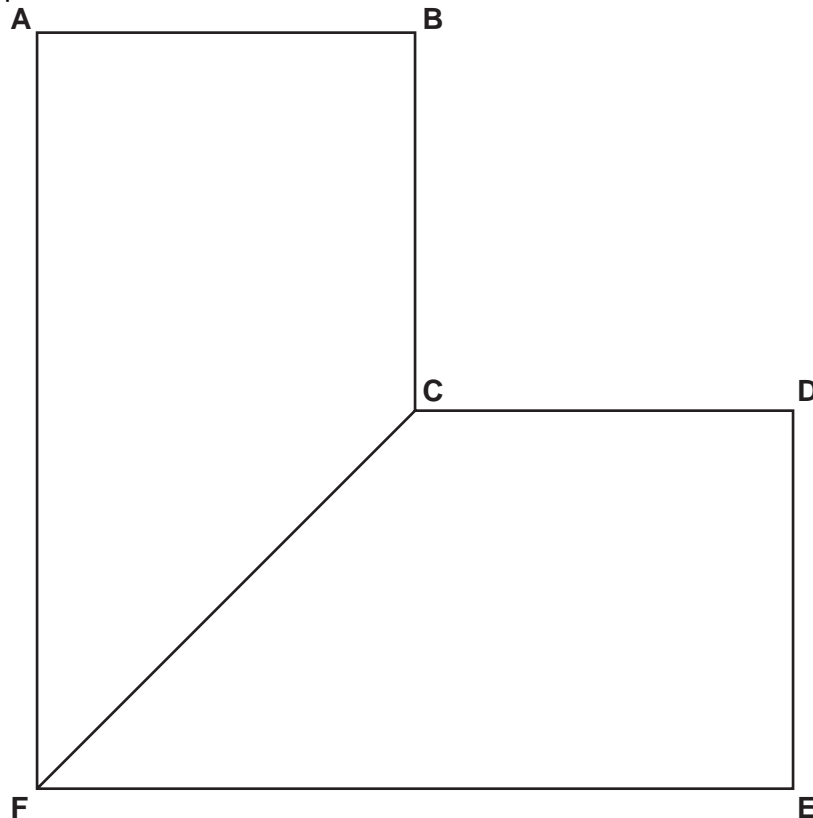

Fig. 2.6

- (c) The student thought that the centre of mass of the card was at **M**.

He pushed the pin through the card at point **M**. He turned the card upside down so the pin was underneath it. The card balanced on the pin.

He tried to make the card balance on point **N**. (See Fig. 2.5)

- (ii) Explain why the card would not balance on point **N**.

.....
..... [1]

- 3 The teacher gives the student samples of three solids, **A**, **B** and **C**. One solid is an acid, one is a base and the other is a salt.
The student does three sets of experiments. He reacts **A**, **B** and **C** with three chemicals. He tests for any gases that are given off.

- (a) The three chemicals are shown in Fig. 3.1. Mark with a tick (✓) where you expect a reaction to take place if they are added to an acid, to a base and to a salt. You should mark **four** boxes. Leave the other boxes blank. [2]

	chemical added		
	sodium carbonate	ammonium chloride	aqueous ammonia
acid			
base			
metal salt			

Fig. 3.1

- (b) The student reacts the solids **A**, **B** and **C** with sodium carbonate. Fig. 3.2 shows the results.

solid A with sodium carbonate in water	solid B with sodium carbonate in water	solid C with sodium carbonate in water
No reaction is seen.	The mixture bubbles and a gas is given off. The gas turns lime-water cloudy.	A white precipitate is seen.

Fig. 3.2

Suggest **one** conclusion that the student can make from these results.

..... [1]

- (c) The student adds the solids **A**, **B** and **C** to solid ammonium chloride. He warms the mixture. Fig. 3.3 shows the results.

solid A with solid ammonium chloride	solid B with solid ammonium chloride	solid C with solid ammonium chloride
A gas is given off. The gas has a strong smell.	No apparent reaction.	No apparent reaction.

Fig. 3.3

- (i) The student thinks that the strong smelling gas is ammonia. Suggest a test to confirm the presence of ammonia and give the result you expect.

.....
 [2]

- (ii) What does this tell you about solid **A**?

..... [1]

- (d) The student adds aqueous ammonia to solutions of **A**, **B** and **C**, until no further reaction is seen. Fig. 3.4 shows the results.

solution of A with aqueous ammonia.	solution of B with aqueous ammonia	solution of C with aqueous ammonia.
No apparent reaction.	A clear solution is left. There is a rise in temperature.	A white precipitate forms. It dissolves when excess ammonia is added.

Fig. 3.4

- (i) Name the kind of reaction that takes place between aqueous ammonia and the solution of **B**.

..... [1]

- (ii) Suggest the identity of the white precipitate formed when solution **C** reacts with aqueous ammonia.

..... [1]

- (e) The student decides which of the solids, **A**, **B** and **C** is a salt. He thinks that the salt is a sulphate.

Describe a test that he can use to confirm the presence of a sulphate in the solution of the salt and give the result that you expect.

test

.....
 result [2]

- 4 A student does an experiment to find out how long it takes for 100 cm^3 of a gas to flow out of a small hole.

He uses a syringe fitted with a tap and a tube ending in a very small hole. The gas will flow out of the hole as the piston of the syringe descends.

The apparatus is shown in Fig. 4.1.

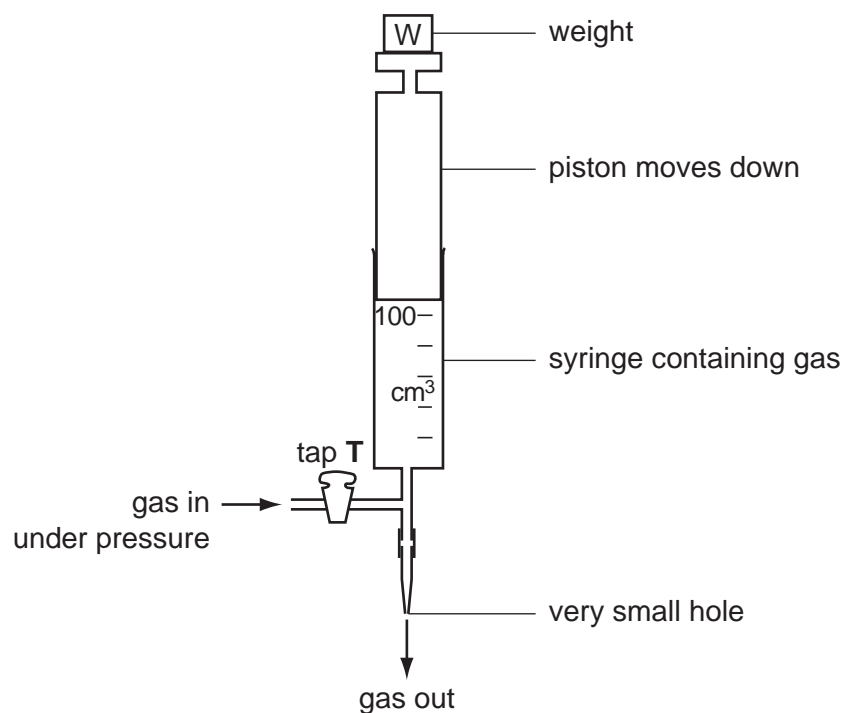

Fig. 4.1

The student follows the list of instructions below. One of the instruction lines is missing.

- (a) Study Fig. 4.1 and the instructions, then fill in the missing line.

List of Instructions

- Make sure the stopclock is set at 0 seconds.
- Open tap T to allow gas to enter the syringe
- When the syringe contains about 110 cm^3 of gas, close tap T.
-
-
- When the syringe is empty, stop the clock.
- Record the time taken in Fig. 4.2. [1]

- (b) The student performed the experiment using four different gases. Two of his results are shown in Fig. 4.2.

gas contained in syringe	oxygen O_2	hydrogen H_2	methane CH_4	chlorine Cl_2
time for 100 cm^3 of gas to flow out/s	30	7		
relative molecular mass of the gas	32	2		

Fig. 4.2

The stopclock dials in Fig. 4.3 show the times taken by 100 cm^3 of each of the other gases to flow out of the syringe.

Read the dials and record the times in Fig. 4.2.

[2]

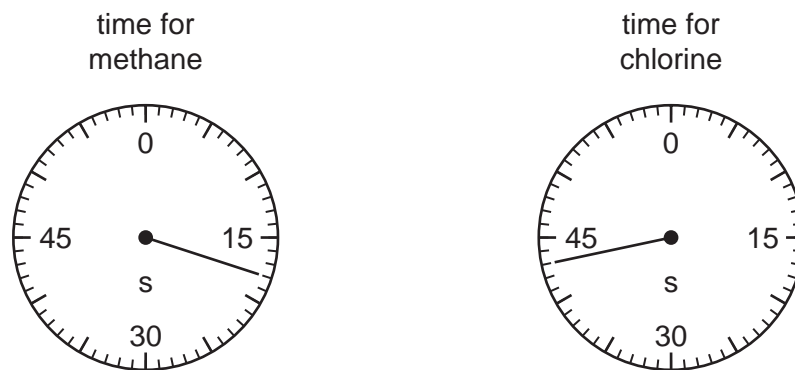

Fig. 4.3

- (c) Calculate the relative molecular masses of methane and chlorine. Record the answers in Fig. 4.2. [Ar: H, 1; C, 12; Cl, 35.5]

[1]

- (d) Suggest a way of making the hydrogen to use in the experiment.

.....
 [1]

The teacher asks the student to explain why the times for the gases to flow out were all different. He makes four suggestions.

- A Gases that have larger molecules flow more slowly.
- B Gas molecules with greater mass flow more slowly.
- C Attraction between molecules causes gases to flow more slowly.
- D Gravity attracts heavier molecules so they flow out more quickly.

(e) (i) Use your knowledge of the kinetic theory of gases to help you to choose the letter of the **best** explanation for the observations made in this experiment.

The best explanation is suggestion [1]

(ii) Choose data from Fig. 4.2 and use it to support the explanation you have chosen in (i).

.....
..... [2]

(f) Suggest **one** safety precaution that should be taken when performing the experiments described in this question. Give a reason for the safety precaution.

safety precaution

reason [2]

- 5 When air is heated, it expands. An experiment was done to investigate this expansion. Air was drawn into a 100 cm³ glass syringe and then the nozzle was sealed. The syringe was placed in a tall beaker of cold water.

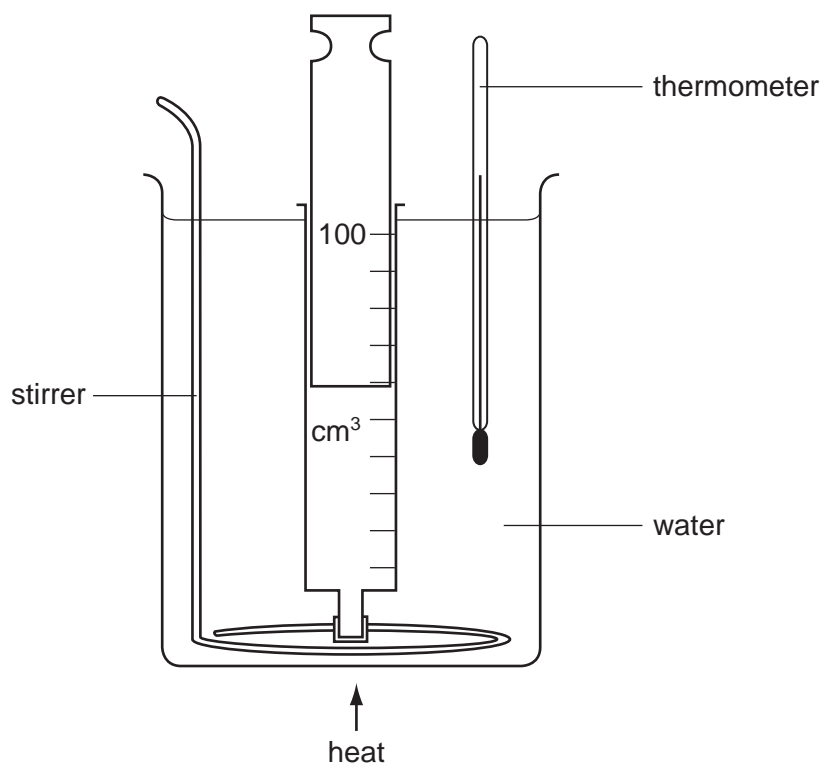

Fig. 5.1

The water was slowly warmed and gently stirred.

At intervals, a thermometer was used to find the temperature of the water. The temperature reading and the volume of air in the syringe were recorded in Fig. 5.2.

reading number	1	2	3	4	5
temperature/°C	2	25	50		
volume/cm ³	53	59	64		

Fig. 5.2

- (a) The scales of the thermometer and the syringe for the two missing readings are shown in Fig. 5.3. Read the temperatures and the volumes and record the values in Fig. 5.2.

[4]

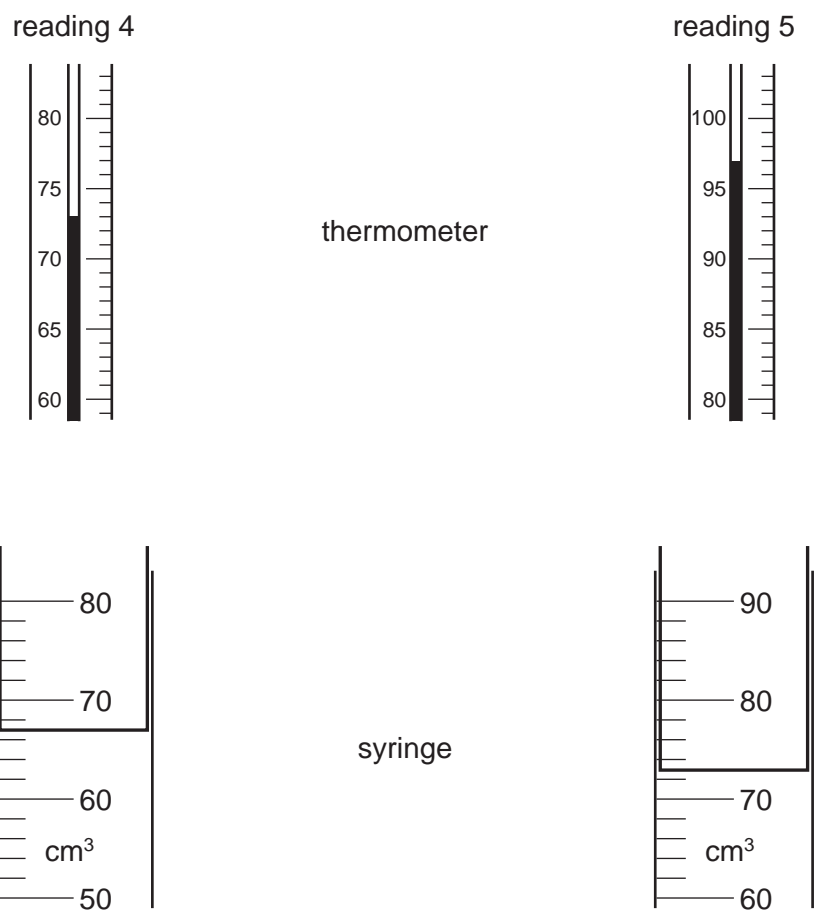
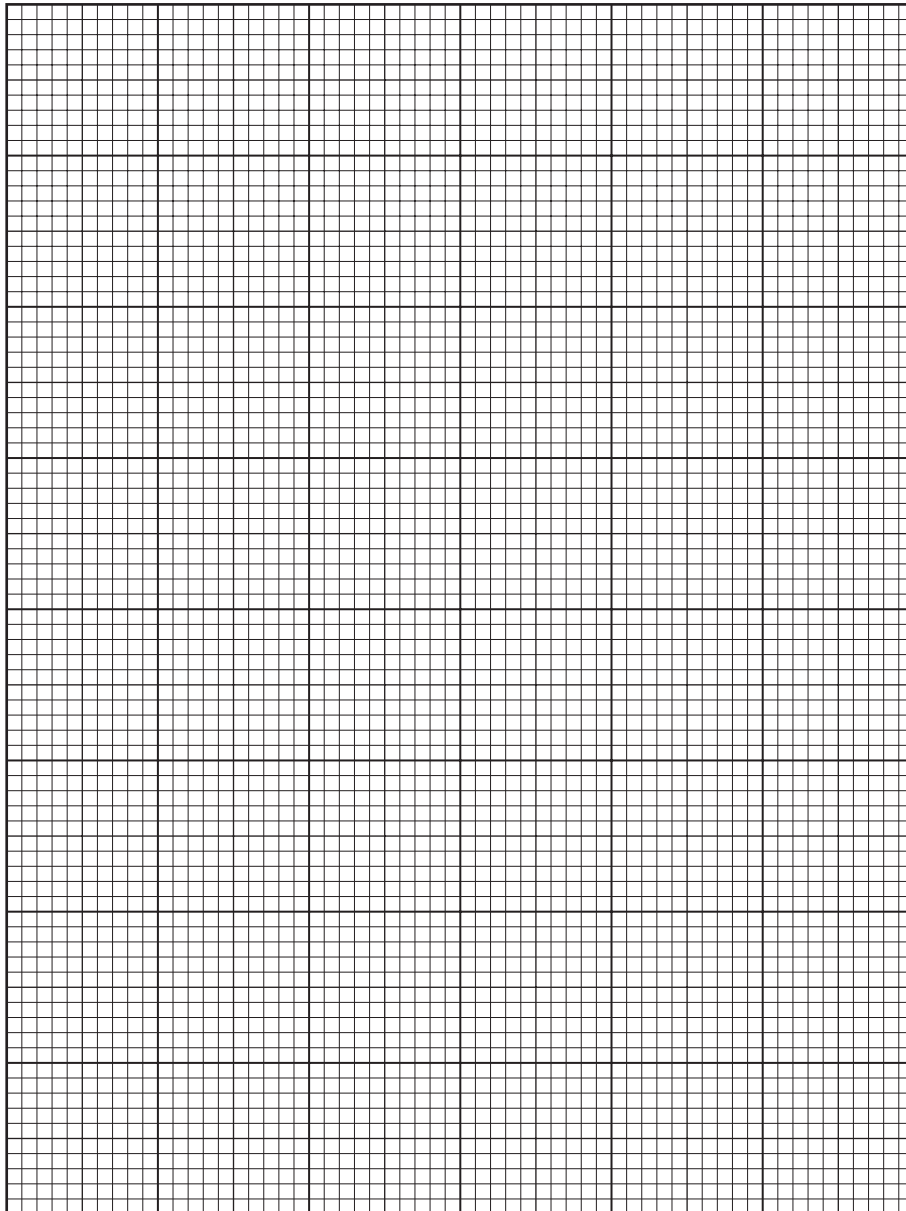

Fig. 5.3

(b) On the grid provided, plot the volume of air (vertical axis) against the temperature. Draw the best fit **straight** line.

[3]



(c) Use your knowledge of the behaviour of gas molecules to explain why the air in the syringe expanded when it was heated.

.....

.....

.....

[2]

- (d) In a different experiment, the sealed syringe containing a hydrocarbon gas was placed in water at room temperature. Then the beaker of water was surrounded by ice at 0°C . The graph shows how the volume of the gas changed as the temperature drops towards 0°C .

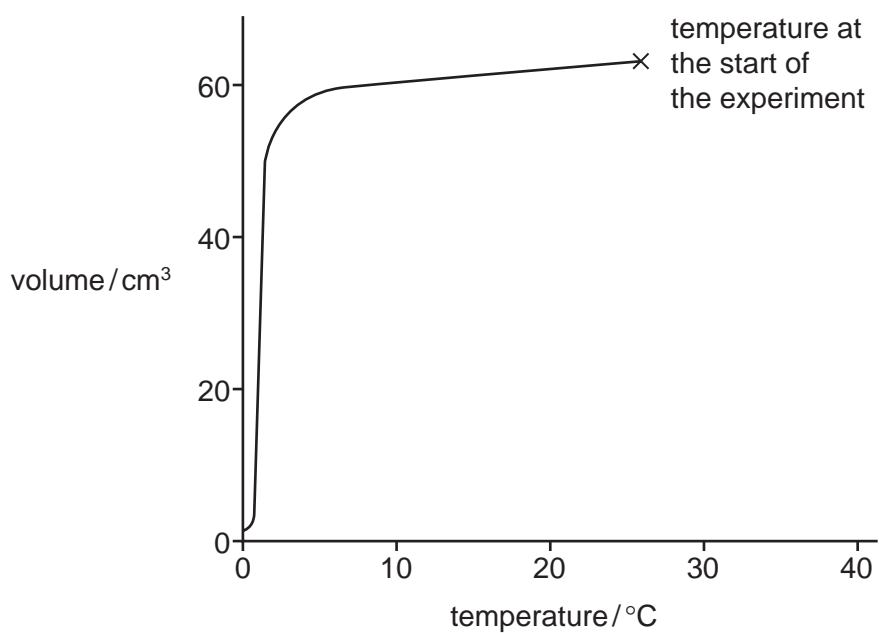

Fig. 5.4

Explain why there was a sudden large decrease in the volume of the gas.

..... [1]

- 6 The teacher gave the class four liquids labelled **A**, **B**, **C** and **D**. She asked them to identify the liquids by doing two experiments and using a key, shown in Fig. 6.2.

First experiment. Finding the density of the liquids.

- A 50 cm^3 measuring cylinder was placed on a balance.
- The balance was adjusted so that it read 0.0 g with the measuring cylinder on the pan.
- 50 cm^3 of each liquid was placed in the cylinder.

Fig. 6.1 shows the balance window for each liquid in turn.

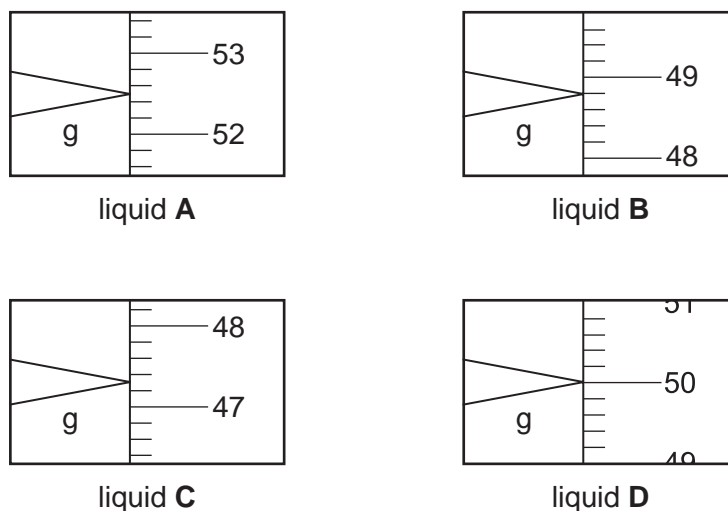

Fig. 6.1

- (a) Read the balance windows and record the masses in the spaces provided.

mass of 50 cm^3 of liquid **A**g

mass of 50 cm^3 of liquid **B**g

mass of 50 cm^3 of liquid **C**g

mass of 50 cm^3 of liquid **D**g

[4]

(b) Use the data from (a) to help you to write the letters of the four liquids in the correct spaces in boxes 1, 2 and 3 of the key, Fig. 6.2. Do not attempt to complete boxes 4 and 5 until you answer part (c). [2]

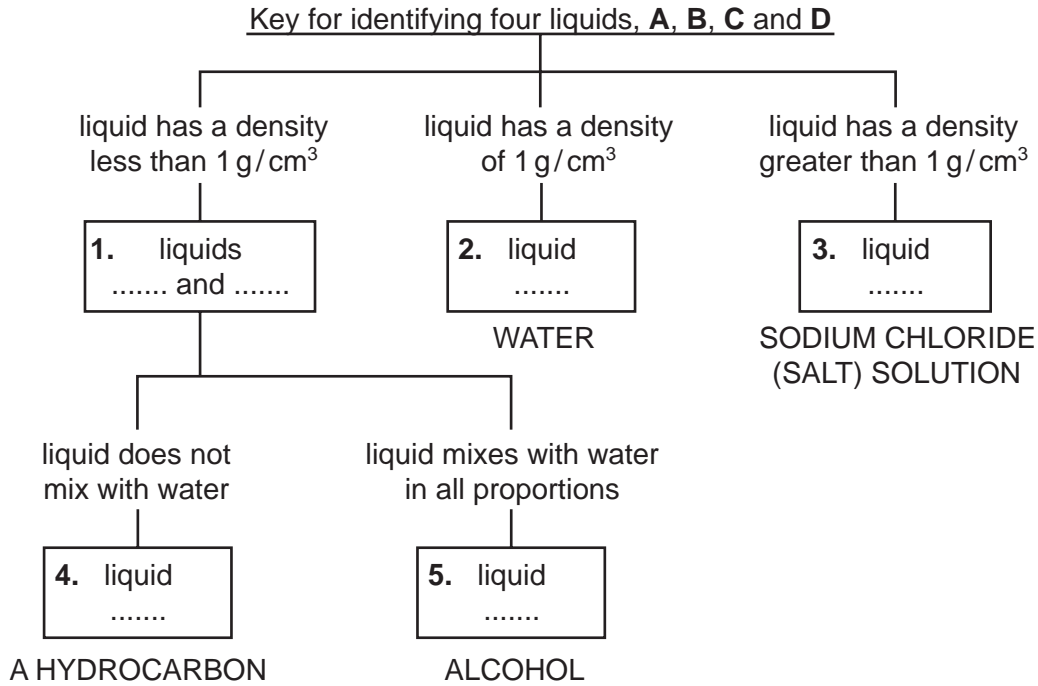

Fig. 6.2

Second experiment. Mixing the liquids with water.

Fig. 6.3. shows the effect of placing 10 cm³ of each of the liquids with 10 cm³ of water in a test-tube.

(c) Use information from Fig. 6.3 to help you to complete boxes 4 and 5 in the key, Fig. 6.2. [1]

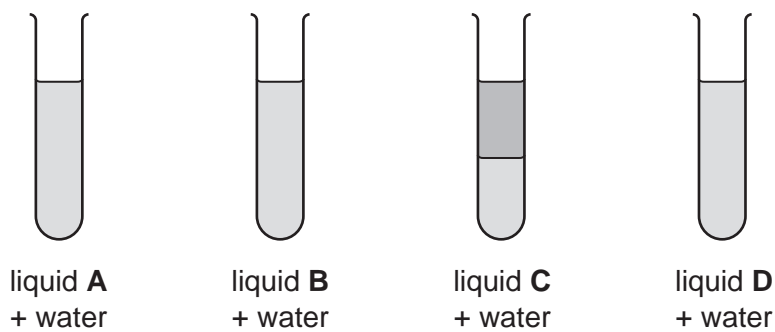

Fig. 6.3

(d) Suggest a different test you can carry out to distinguish between the alcohol and the hydrocarbon.

.....
..... [1]

(e) Describe a chemical test you can carry out to confirm the identity of the salt solution.

.....
..... [2]

Permission to reproduce items where third-party owned material protected by copyright is included has been sought and cleared where possible. Every reasonable effort has been made by the publisher (UCLES) to trace copyright holders, but if any items requiring clearance have unwittingly been included, the publisher will be pleased to make amends at the earliest possible opportunity.

University of Cambridge International Examinations is part of the Cambridge Assessment Group. Cambridge Assessment is the brand name of University of Cambridge Local Examinations Syndicate (UCLES), which is itself a department of the University of Cambridge.