

- 1 Ticker tape is attached to a model car which moves across a bench from left to right.

This is shown in Fig. 1.1.

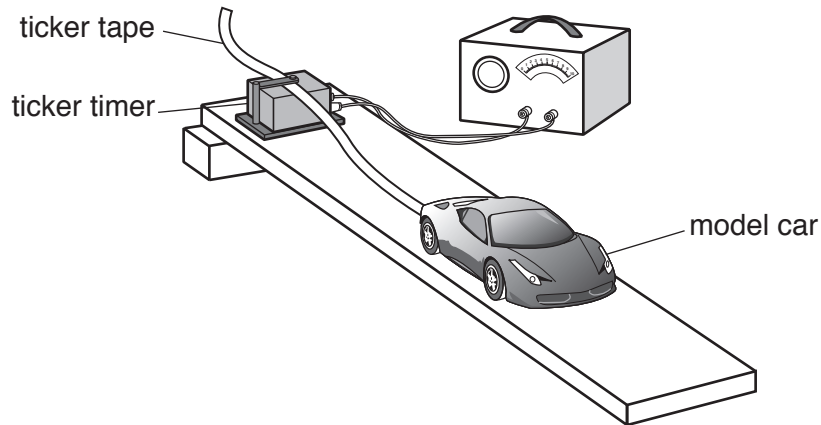

Fig. 1.1

The ticker tape passes through a ticker timer, which prints a dot on the tape every 0.01 s.

Fig. 1.2 shows part of the ticker tape next to a metre ruler.

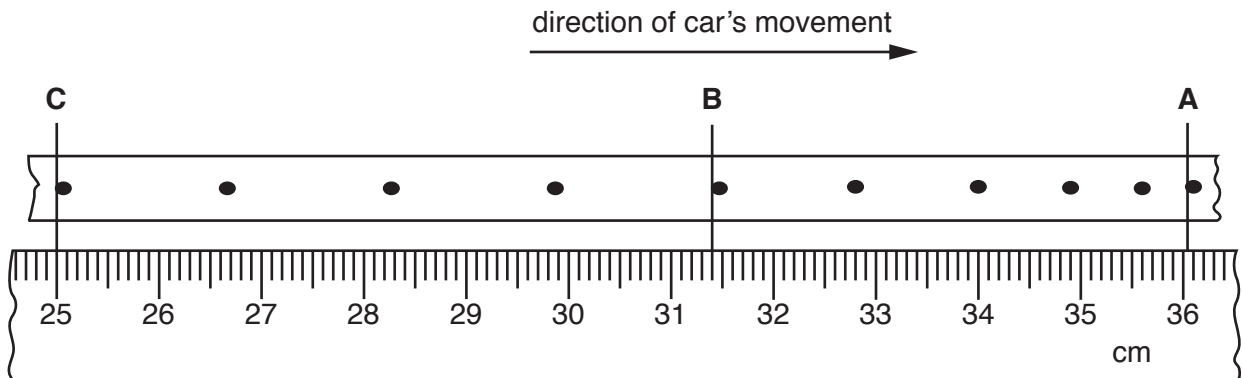

Fig. 1.2

- (a) (i) The speed of the car can be calculated from the spacing of the dots.

Calculate the speed of the car during the time that the section **BC** of the tape was made.

speed = cm/s [3]

- (ii) Describe the motion of the car during the time that section **AB** was made.

.....[1]

(b) On Fig. 1.3, sketch a speed/time graph for the motion of the car from time **A** to time **C**.



Fig. 1.3

[2]

(c) Describe how the acceleration of an object can be found from a speed/time graph.

.....
.....[1]

- 2 Fig. 2.1 shows the apparatus used to measure the temperature change that occurs during an exothermic reaction.

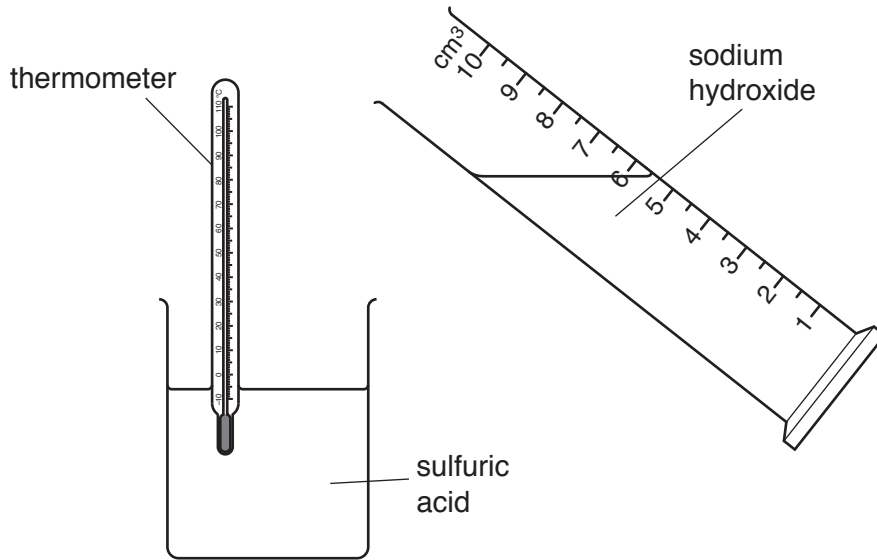

Fig. 2.1

- (a) Predict what will happen to the temperature of the mixture during this reaction.

.....
[1]

- (b) Explain why this reaction is exothermic.

You should refer to bond breaking and bond forming in your answer.

.....

[2]

- (c) A student wants to increase the rate of reaction between sulfuric acid and sodium hydroxide.

Suggest **one** way the rate of this reaction could be increased.

.....

[1]

- (d) Complete the symbol equation for the reaction between sulfuric acid and sodium hydroxide.



- (e) Plants produce glucose and oxygen in an endothermic reaction called photosynthesis.

The equation for the reaction for photosynthesis is shown below.

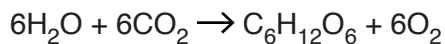

- (i) Calculate the mass of glucose, $\text{C}_6\text{H}_{12}\text{O}_6$, made when 1.0g of water reacts with carbon dioxide.

[Ar: C, 12; H, 1; O, 16]

Show your working in the box.

mass of glucose = g

[3]

- (ii) Outline how green plants obtain the energy needed for photosynthesis to occur.

.....

.....

..... [2]

- 3 Fig. 3.1 shows a crane lifting a load of bricks of weight 5000 N from the ground to a height of 8.5 m.

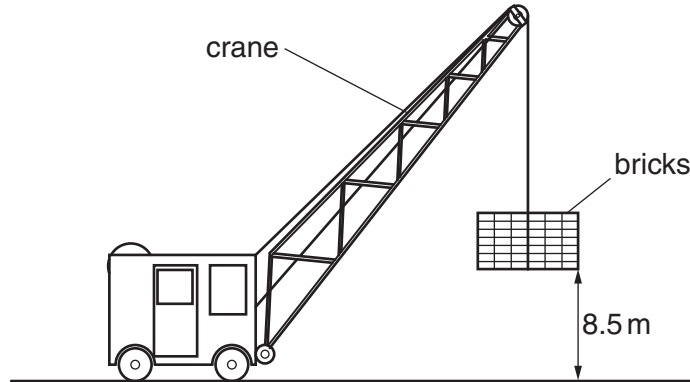

Fig. 3.1

- (a) (i) Calculate the work done against gravity in lifting the bricks.

Show your working.

work done = J [2]

- (ii) The energy transferred from the fuel to the crane's motor is considerably greater than the work done to lift the bricks in part (i).

Use this information to explain what is meant by the term *efficiency*.

.....
 [1]

- (b) The crane takes 12 s to raise the bricks to the height of 8.5 m.

Calculate the power produced in raising the bricks.

Show your working and give the unit.

power = unit [3]

- 4 (a) A student wants to determine the order of reactivity of four metals, **A** to **D**.

She tests each metal with cold water, steam and dilute hydrochloric acid.

Her results are shown in Table 4.1.

Table 4.1

metal	reaction with cold water	reaction with steam	reaction with hydrochloric acid
A	no	yes	yes
B	slowly	yes	yes
C	yes	yes	yes
D	no	no	no

Deduce the order of reactivity for the metals **A** to **D**.

most reactive

.....

.....

least reactive

[2]

(b) The diagram in Fig. 4.1 shows three uses for metals.

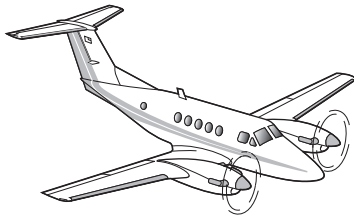

aeroplane

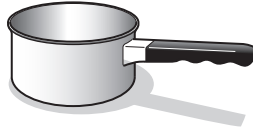

saucepan



cutlery

Fig. 4.1

Suggest three different metals that could be used to make each of the items shown above. Use ideas about the properties of the different metals to explain your choice.

(i) aeroplane

metal

reason

.....[1]

(ii) saucepan

metal

reason

.....[1]

(iii) cutlery

metal

reason

.....[1]

(c) Metals are good conductors of electricity.

Use ideas about metallic structure and bonding to explain why metals conduct electricity.

You may draw and label a diagram to help your answer.

.....

.....

.....

.....[3]

5 Fig. 5.1 shows a harbour and some anchored boats, viewed from above.

One wavefront of the waves out at sea is labelled.

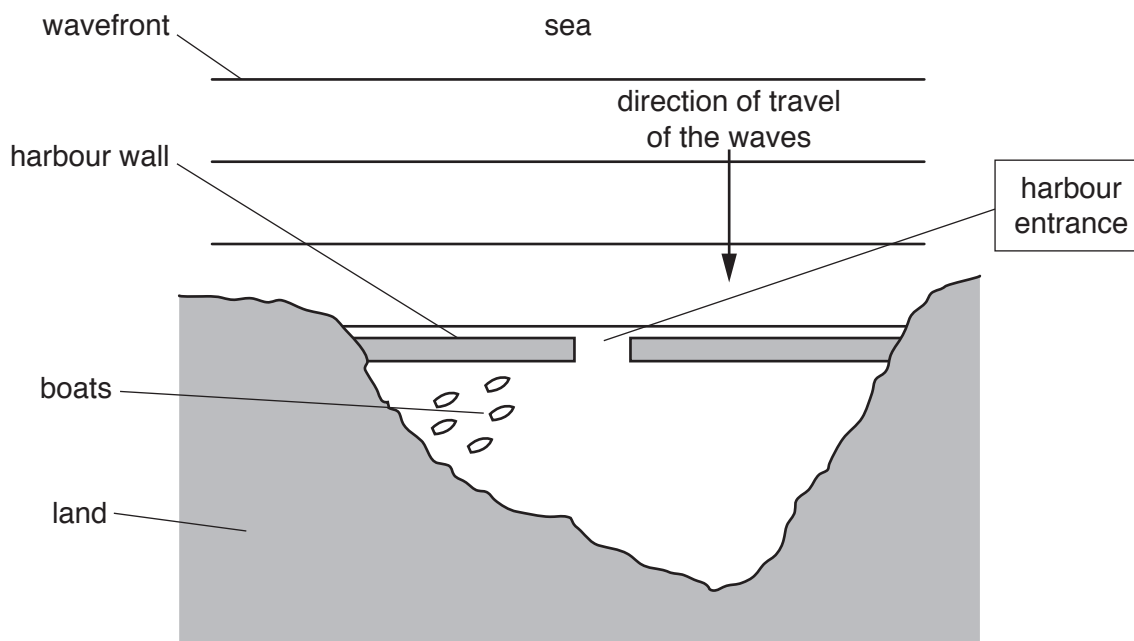

Fig. 5.1

(a) (i) Draw, on Fig. 5.1, **three** wavefronts after they pass through the harbour entrance. [3]

(ii) Name the property of waves which is demonstrated by the behaviour of the waves after they have passed through the harbour entrance.

..... [1]

(iii) The boats in the harbour are sheltered by the harbour wall but still move up and down.

Refer to your diagram to explain why the boats move up and down.

.....
[1]

(b) A girl stands on the harbour wall and counts the waves hitting the harbour wall.

In 2 minutes she counts 6 waves hitting the wall.

(i) Calculate the frequency of the waves.

frequency = Hz [2]

(ii) She estimates the distance between successive crests of the waves as 25 m.

State the wavelength of the waves.

wavelength = m [1]

(iii) Calculate the speed at which the waves travel towards the harbour wall.

speed = m/s [2]

- 6 (a) Bauxite, haematite and malachite are three metal ores.

State the metal found in malachite.

.....[1]

- (b) Fig. 6.1 shows a blast furnace used to extract iron from its ore.

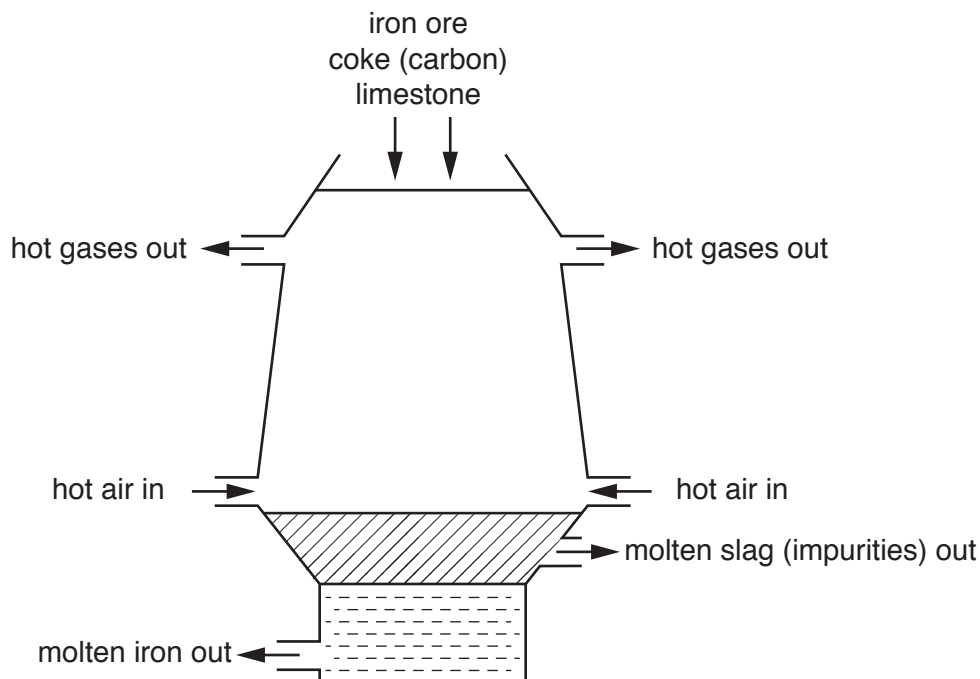

Fig. 6.1

- (i) Explain why it is possible to extract the iron metal from its ore by reacting the ore with carbon.

.....
[1]

- (ii) Suggest why heated air is forced into the blast furnace.

You may use an equation to help your answer.

.....

[2]

- (iii) Complete the symbol equation to show the products of the reaction between iron oxide and carbon monoxide in the blast furnace.

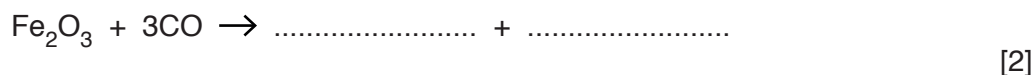

- (c) State the role of the calcium carbonate (limestone) in the extraction of iron from haematite.

.....
.....[1]

- (d) Calcium carbonate (limestone) is also used in the manufacture of calcium oxide (lime).

- (i) Write a word equation for the reaction of calcium carbonate to form calcium oxide.

.....[1]

- (ii) State the name given to this type of reaction.

.....[1]

- 7 Fig. 7.1 is a diagram of a circuit in which there is a battery of e.m.f. 9.0V, three resistors and three voltmeters **A**, **B** and **C**.

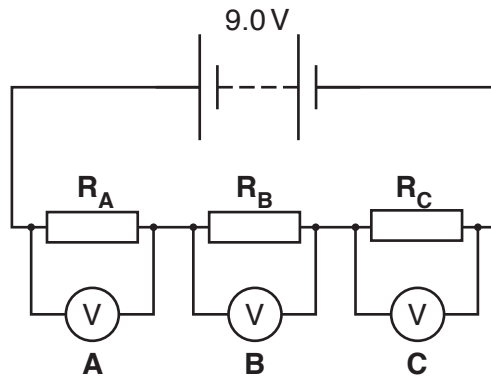

Fig. 7.1

- (a) Table 7.1 shows the readings on voltmeters **A** and **B**.

Table 7.1

reading on voltmeter A / V	reading on voltmeter B / V	reading on voltmeter C / V
4.2	3.6	

Complete Table 7.1 to show the reading on voltmeter **C**.

[1]

- (b) (i) The current through **R_A** is 0.40A.

Calculate the energy dissipated in **R_A** in 5.0 minutes.
Show your working and state the unit.

energy = unit [3]

- (ii) Determine the current through **R_B** and **R_C**.

current through **R_B** = A

current through **R_C** = A [1]

(c) Fig. 7.2 shows the same 9.0 V battery connected across two resistors in parallel.

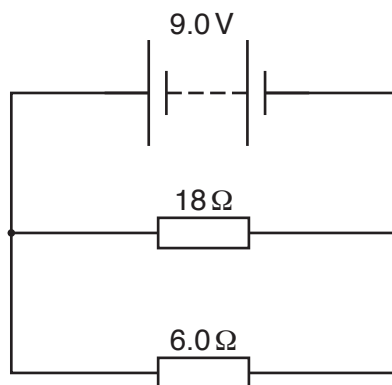

Fig. 7.2

(i) Calculate the combined resistance of the two resistors.

resistance = Ω [2]

(ii) Calculate the current in the battery.

current = A [1]

(iii) Calculate the charge passing through the battery in 30 seconds.

charge = C [2]

- 8 Table 8.1 shows data for the atomic radii of elements in Group II of the Periodic Table.

Table 8.1

Group II element	atomic radius / nm
beryllium	0.125
magnesium	0.160
calcium	0.174
strontium	-----
barium	0.198

- (a) Suggest a value for the atomic radius of strontium.

..... nm [1]

- (b) State the number of electrons barium has in its outer electron shell.

.....[1]

- (c) Magnesium can be reacted with the Group VII element chlorine to form the ionic compound magnesium chloride.

Describe the formation of ionic bonds between magnesium and chlorine.
You should draw and label a diagram to help your answer.

.....

[4]

Question 9 begins over the page.

9 Fig. 9.1 shows a simple alternating current (a.c.) generator.

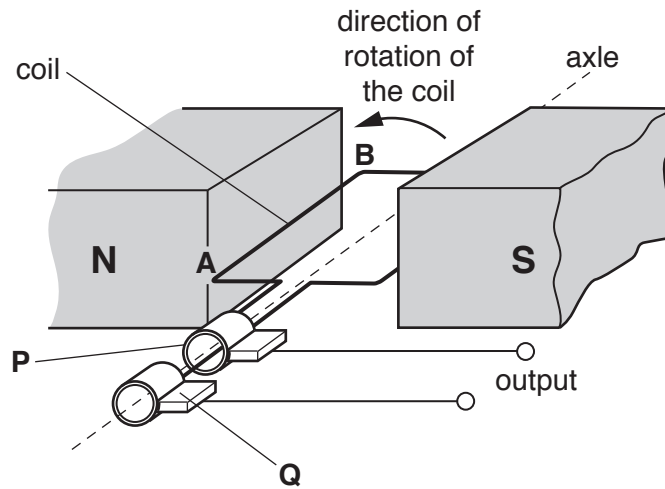

Fig. 9.1

(a) Name the parts labelled **P** and **Q** in Fig 9.1.

P

Q

[2]

(b) Explain why an e.m.f. is induced across the section **AB** of the coil when the coil rotates.

.....

 [2]

- (c) (i) A resistor is connected across the generator. There is an alternating current in the resistor.

Explain what is meant by the term *alternating current*.

.....
[1]

- (ii) Fig. 9.2 shows the screen of a cathode ray oscilloscope (c.r.o.).

The output from the a.c. generator is connected to the c.r.o.

Draw, on Fig. 9.2, two complete cycles of the trace seen on the screen of the oscilloscope.

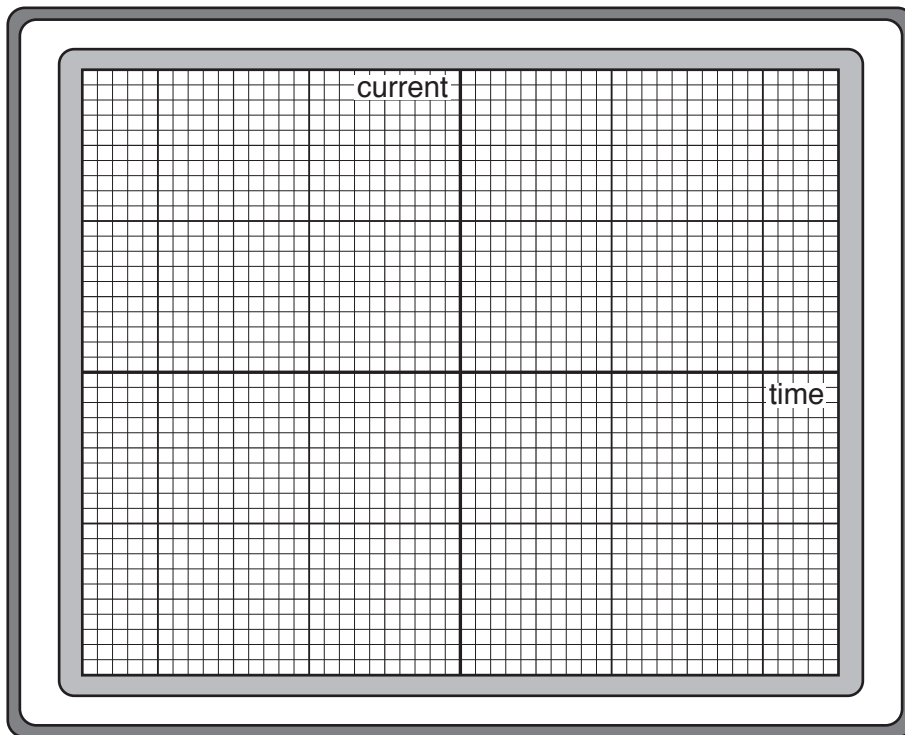

Fig. 9.2

[2]

10 Graphite and diamond are both forms of carbon.

Table 10.1 shows some physical properties of graphite and diamond.

Table 10.1

	melting point / °C	hardness
graphite	3600	soft
diamond	4000	hard

Fig. 10.1 shows the structure of graphite and diamond.

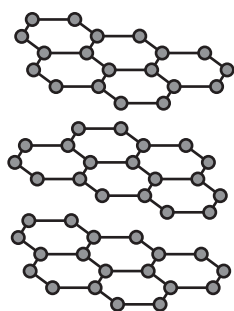

graphite

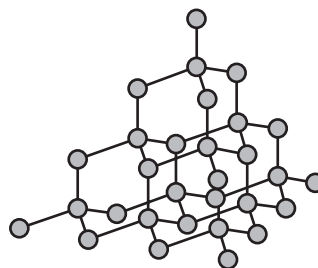

diamond

Fig. 10.1

(a) Use Table 10.1 and Fig. 10.1 to explain the following properties of graphite and diamond.

(i) hardness

.....

.....

.....[3]

(ii) melting point

.....[1]

(b) Carbon is one of the elements found in ethanol and ethene.

Name the process used to produce ethanol from ethene.

.....[1]

(c) Draw a diagram to show the electron arrangement in ethene, C_2H_4 .

[2]

