

UNIVERSITY OF CAMBRIDGE INTERNATIONAL EXAMINATIONS
International General Certificate of Secondary Education

MARK SCHEME for the May/June 2009 question paper
for the guidance of teachers

0653 COMBINED SCIENCE

0653/02

Paper 2 (Core Theory), maximum raw mark 80

This mark scheme is published as an aid to teachers and candidates, to indicate the requirements of the examination. It shows the basis on which Examiners were instructed to award marks. It does not indicate the details of the discussions that took place at an Examiners' meeting before marking began, which would have considered the acceptability of alternative answers.

Mark schemes must be read in conjunction with the question papers and the report on the examination.

- CIE will not enter into discussions or correspondence in connection with these mark schemes.

CIE is publishing the mark schemes for the May/June 2009 question papers for most IGCSE, GCE Advanced Level and Advanced Subsidiary Level syllabuses and some Ordinary Level syllabuses.



Page 2	Mark Scheme: Teachers' version	Syllabus	Paper
	IGCSE – May/June 2009	0653	02

- 1 (a) A enamel ;
 B dentine ;
 C pulp/blood vessel/nerve ; [3]
 [reject roof]
- (b) break down large pieces of food to small ones ;
 increase surface area ;
 making it easier for enzymes to act ; [max 2]
- (c) calcium/phosphate ;
 D ; [2]
- [Total: 7]**
- 2 (a) (i) all symbols shown ;
 voltmeter in parallel with lamp only ; [3]
 all other components in series ;
- (ii) to vary current (through lamp)/voltage/PD (across lamp) ; [1]
 [ignore refs. to power if with correct statements]
- (iii) $(R =) V/I$;
 = 5.3 ; [2]
 [accept words]
 [accept only suitable symbols, so V/I (= ohms) is accepted but V/A is not]
- (b) damaged outer insulation/owtte ;
 short circuit/risk of shock/risk of fire ; [2]
- [Total: 8]**
- 3 (a) neon ;
 chlorine ; [3]
 cobalt ;
- (b) (i) 12 ; [1]
- (ii) carbon ;
 (nucleus/atom has) 6 protons/it has a proton number 6 ; [2]
 [accept other unambiguous statements]
- (c) hydrogen ;
 appropriate metal e.g. Ca Mg Al Zn Fe ;
 [reject Group 1]
 suitable acid – could be several correct answers but expect HCl H₂SO₄ HNO₃ ; [3]
- [Total: 9]**

Page 3	Mark Scheme: Teachers' version	Syllabus	Paper
	IGCSE – May/June 2009	0653	02

- 4 (a) (i) anther/stamen ; [1]
(ii) male gametes ; [1]
(iii) the transfer of pollen ;
to a stigma ; [2]
- (b) (i) the higher the temperature, the more oxygen is used ; [1]
(ii) respiration ;
aerobic ;
using oxygen to produce heat ;
by breaking down glucose ; [max 2]
- (c) photosynthesis ;
(using) light/sunlight ;
combining water and carbon dioxide/correct equation ; [max 2]
- (d) cell wall drawn and labelled ;
cell membrane labelled immediately inside the cell wall ;
nucleus drawn and labelled, in the cytoplasm ;
chloroplast drawn and labelled, in the cytoplasm ;
vacuole drawn and labelled ; [max 4]
- [Total: 13]**
- 5 (a) (i) (average speed =) distance / time ;
= 900 / 150 = 6 km/h ; [2]
(ii) 2 m/s ; [1]
- (b) friction and thrust/upthrust and weight ; [1]
- (c) insulation ;
(trapped) air (is an insulator) ;
prevents conduction/convection ; [3]
- (d) density = mass ÷ volume / mass = density × volume ;
mass = 800 × 9 = 7200 (kg) ; [2]
- (e) (i) solar/sunlight/waves/tides/geothermal/biofuel/hydro (reject nuclear) ; [1]
(ii) coal/oil/gas/(named) fossil fuel/peat (reject nuclear) ; [1]

[Total: 11]

6 (a)

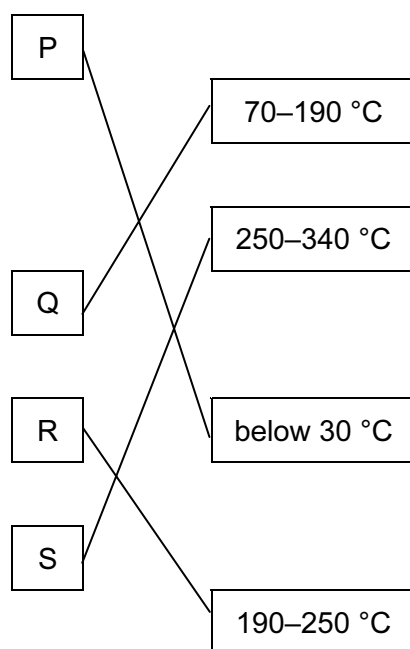

(2 marks for 3 correct, 1 mark for 1 or 2 correct)

[2]

- (b) (i) plastic buckets lighter (to carry) ;
flexible, not bent out of shape in use ;
no reaction with content of bucket
impermeable ;
easily be shaped ;

[max 1]

- (ii) oxygen ;
water ;

[2]

- (iii) galvanising/cover in layer of zinc/painting ;

[1]

- (iv) iron ;

[1]

- (v) stainless steel ;

[1]

[Total: 8]

7 (a)

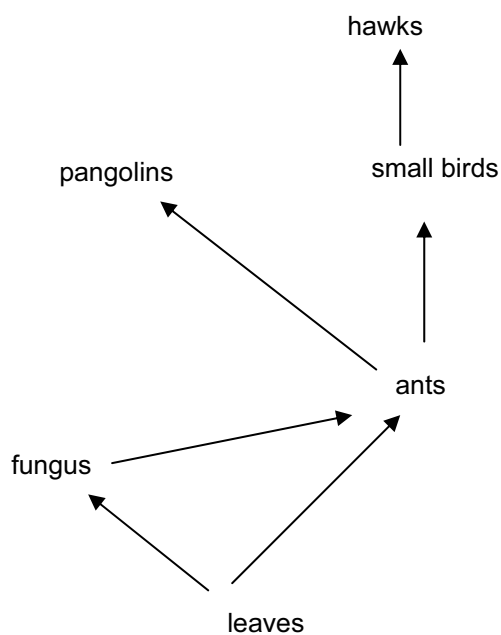

all organisms included ;
 all connected correctly by lines ;
 with correct arrow heads ;

[3]

(b) (i) leaves/trees ;

[1]

(ii) fungus ;

[1]

(c) ref. to loss of habitat ;
 pangolins eat ants, which eat leaves ;
 if fewer leaves then fewer ants so fewer pangolins ;

[max 2]

[Total: 7]

8 (a) (i) weight of empty lift = 12000 N ;
 combined weight = 12800 N ;

[2]

(ii) $W = F \times D$;
 [accept (work done =) height \times (total) weight]
 = 12 800 \times 9 = 115 200 J ;
 ecf for incorrect total weight from (i)

[2]

(b) (i) vibrations ;
 of molecules/particles ;
 longitudinal wave ;
 compressions and rarefactions ;

[max 2]

(ii) louder ;

[1]

[Total: 7]

Page 6	Mark Scheme: Teachers' version	Syllabus	Paper
	IGCSE – May/June 2009	0653	02

- 9 (a) A filtration ; [2]
 B evaporation/crystallization ;
- (b) to speed up the reaction ; [2]
 (powders have) a greater surface area (which speeds reaction) ;
- (c) (i) zinc sulfate ; [1]
- (ii) → copper sulfate + carbon dioxide + water ; [2]
 (2 marks for 3 correct 1 mark for 2 correct)
 [reject symbols or formulae even if correct]
- (d) (i) (not balanced) [2]
 must have the same number of each type of atom on both sides ;
(reject same number of atoms needed on both sides)
 some correct detail e.g. 1 H on left but 2 on right/would need 2HCl ;
- (ii) reaction is exothermic/heat given out (to surroundings) ; [1]

[Total: 10]