



UNIVERSITY OF CAMBRIDGE INTERNATIONAL EXAMINATIONS  
International General Certificate of Secondary Education

www.XtremePapers.com

**COMBINED SCIENCE**

**0653/01**

Paper 1 Multiple Choice

**May/June 2009**

**45 minutes**

Additional Materials: Multiple Choice Answer Sheet  
Soft clean eraser  
Soft pencil (type B or HB is recommended)

\* 5 5 0 2 2 8 6 7 5 6 \*

**READ THESE INSTRUCTIONS FIRST**

Write in soft pencil.

Do not use staples, paper clips, highlighters, glue or correction fluid.

Write your name, Centre number and candidate number on the Answer Sheet in the spaces provided unless this has been done for you.

There are **forty** questions on this paper. Answer **all** questions. For each question there are four possible answers **A, B, C** and **D**.

Choose the **one** you consider correct and record your choice in **soft pencil** on the separate Answer Sheet.

**Read the instructions on the Answer Sheet very carefully.**

Each correct answer will score one mark. A mark will not be deducted for a wrong answer.

Any rough working should be done in this booklet.

A copy of the Periodic Table is printed on page 20.

This document consists of **17** printed pages and **3** blank pages.



1 Which pair of features is found in plant cells but **not** in animal cells?

<b>A</b>	cell membrane	cell sap
<b>B</b>	cell sap	cell wall
<b>C</b>	cell wall	nucleus
<b>D</b>	nucleus	cell membrane

2 Which parts of a plant cell are fully permeable?

	cell surface membrane	cell wall
<b>A</b>	✓	✓
<b>B</b>	✓	x
<b>C</b>	x	✓
<b>D</b>	x	x

3 The following statements are about enzymes and metabolic reactions.

- 1 Different metabolic reactions are catalysed by different enzymes.
- 2 Enzymes are produced only inside living cells.
- 3 Enzymes cannot be re-used.
- 4 Metabolic reactions take place only inside living cells.

Which two statements are correct?

- A** 1 and 2      **B** 2 and 3      **C** 3 and 4      **D** 4 and 1

- 4 The diagram shows **only the left side** of the heart as it appears at one particular stage in a heart-beat.

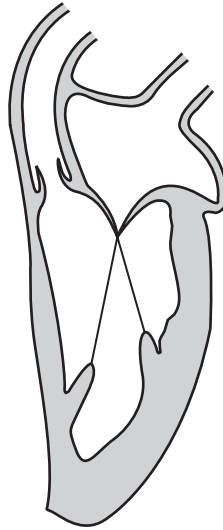

Which statements describe the left side of the heart at this stage?

- 1 The semilunar valve is closed.
- 2 Deoxygenated blood is being pumped to the lungs.
- 3 Oxygenated blood is entering the atrium.
- 4 The bicuspid valve is closed.

**A** 1 and 2      **B** 1 and 3      **C** 2 and 4      **D** 3 and 4

- 5 The diagram shows a section through a leaf.

Where does evaporation of water take place?

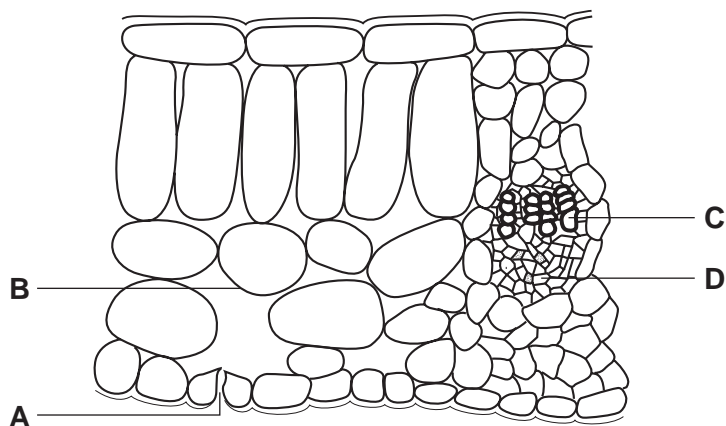

6 The results of tests carried out on four food samples are shown.

sample	Benedict's test	iodine test	biuret test
1	✓	✓	✗
2	✓	✗	✓
3	✗	✓	✗
4	✗	✗	✓

key  
 ✓ = positive test  
 ✗ = negative test

Which two samples contain protein?

- A** 1 and 2      **B** 1 and 3      **C** 2 and 4      **D** 3 and 4

7 The diagram shows a section through part of a lung.

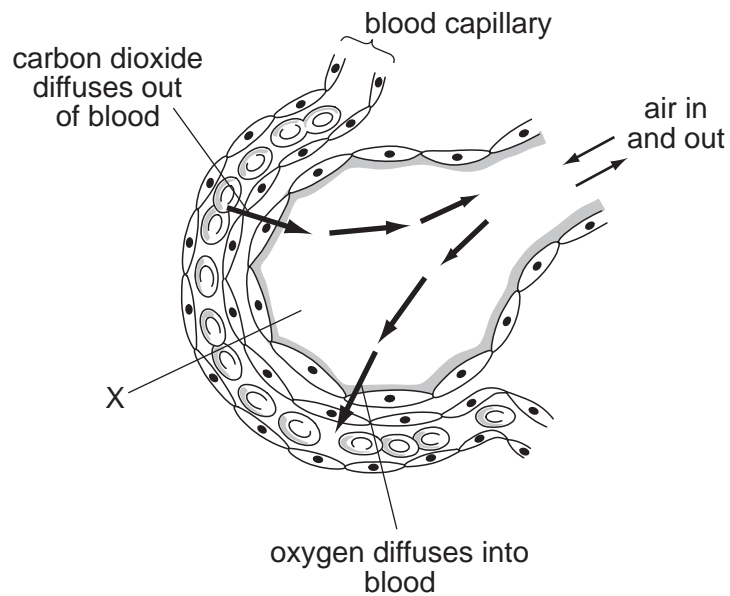

What is structure X?

- A** alveolus  
**B** bronchus  
**C** pleural membrane  
**D** trachea

8 The following statements are about reproduction.

- 1 Clones grown in different environments will always look exactly alike.
- 2 Clones possess identical genes.
- 3 Sexual reproduction produces offspring with different alleles.
- 4 When two gametes fuse they form a clone.

Which two statements are correct?

- A** 1 and 2      **B** 1 and 4      **C** 2 and 3      **D** 3 and 4

9 The diagram shows the human female reproductive system.

Where is the egg fertilised?

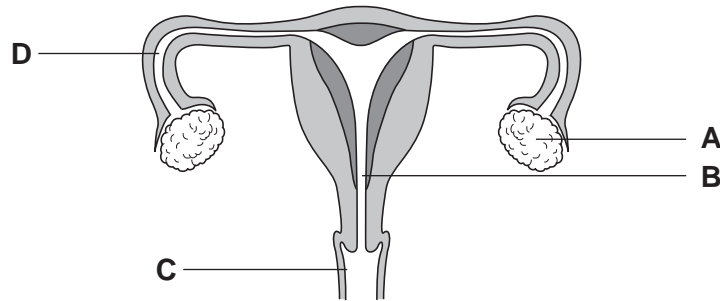

10 After fertilisation, which part of a flower develops into a seed?

- A** egg  
**B** ovary  
**C** ovule  
**D** pollen

- 11 Ten plants are produced asexually from one parent plant. The diagram shows these ten plants after they have grown for a few weeks in two separate groups.



What is the explanation for the difference between the two groups of plants?

- A All the plants are genetically identical and are growing in the same conditions.
  - B All the plants are genetically identical but are growing in different conditions.
  - C The plants are genetically different and are growing in the same conditions.
  - D The plants are genetically different and are growing in different conditions.
- 12 Which process takes carbon dioxide out of the air?

- A combustion
- B decomposition
- C photosynthesis
- D respiration

13 The graph shows the number of species of plants in different parts of a rainforest.

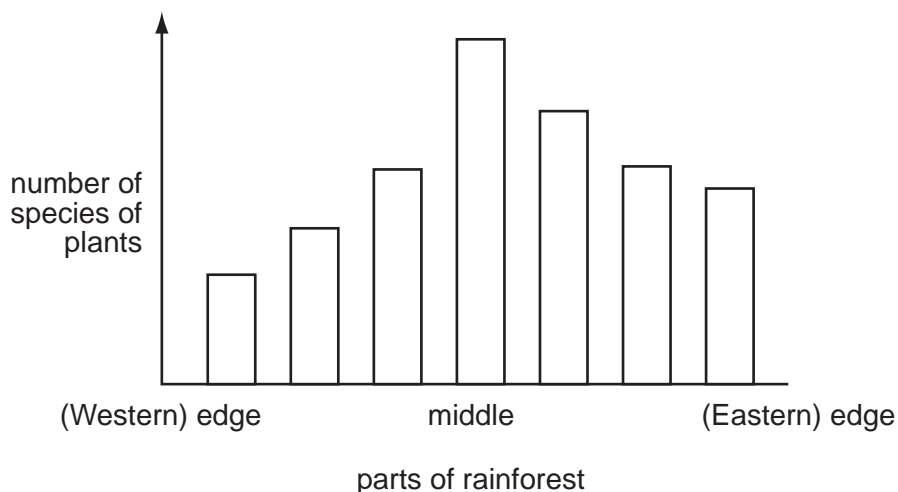

Which statement about species diversity is correct?

- A It is greatest at the edges of the forest.
- B It is greatest in the middle of the forest.
- C Is the same at both edges of the forest.
- D It is the same throughout the forest.

14 Diagrams X, Y and Z represent three different substances.

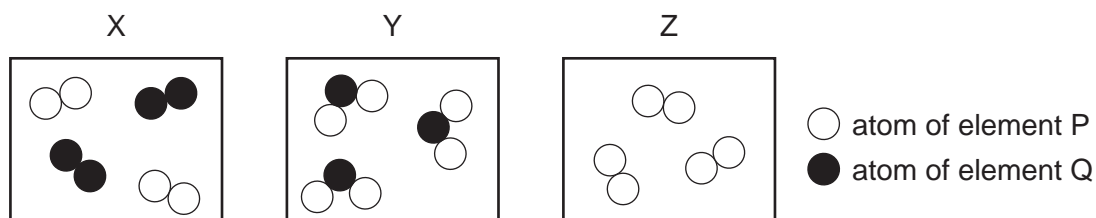

Which row in the table correctly describes X, Y and Z?

	X	Y	Z
<b>A</b>	compound	element	mixture
<b>B</b>	compound	mixture	element
<b>C</b>	mixture	element	compound
<b>D</b>	mixture	compound	element

- 15 Two atoms have the symbols  ${}^{40}_{18}\text{X}$  and  ${}^{40}_{20}\text{Y}$ .

It follows that they have the same number of .....1..... and that they form .....2..... bond.

Which words correctly complete gaps 1 and 2?

	1	2
<b>A</b>	neutrons	an ionic
<b>B</b>	neutrons	no
<b>C</b>	nucleons	an ionic
<b>D</b>	nucleons	no

- 16 Which diagrams of the structures of nitrogen and ammonia are correct?

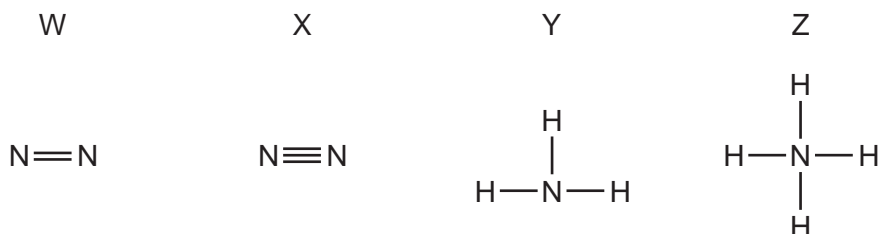

- A** W and Y      **B** W and Z      **C** X and Y      **D** X and Z

- 17 The positions of four elements are shown in the outline of the Periodic Table.

Which element has a high melting point and forms coloured compounds?

<b>C</b>	<b>D</b>								<b>A</b>											<b>B</b>

- 18 A molecule of phosphoric acid contains three hydrogen atoms, one phosphorus atom and four oxygen atoms.

What is the correct formula for this molecule?

- A**  $3\text{HP}_4\text{O}$       **B**  $3\text{HPO}_4$       **C**  $\text{H}_3\text{PO}_4$       **D**  $\text{H}_3(\text{PO})_4$



- 19 The diagram shows apparatus in which gas P can be passed through liquid X and then over iron filings.

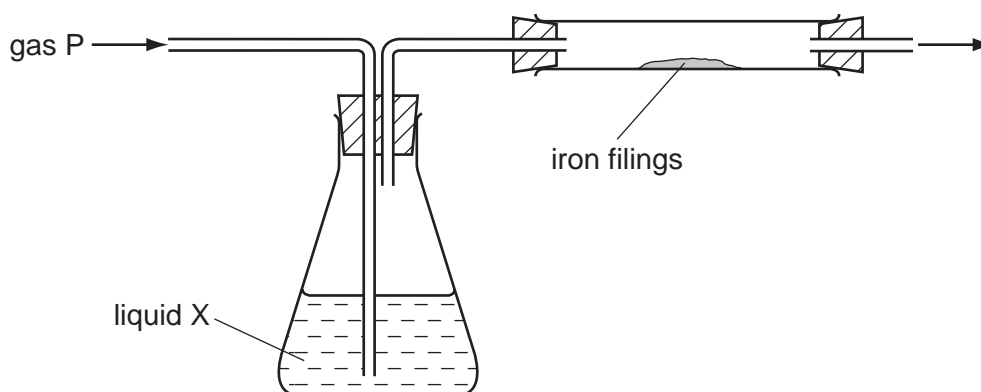

Four experiments, each using a different gas P and a different liquid X, are carried out.

In which experiment do the iron filings rust?

	gas P	liquid X
<b>A</b>	nitrogen	concentrated sulfuric acid (a drying agent)
<b>B</b>	nitrogen	water
<b>C</b>	oxygen	concentrated sulfuric acid (a drying agent)
<b>D</b>	oxygen	water

- 20 A firework gives a bright flame in which yellow and red colours are seen.

Which two metals are present in the firework?

- A** calcium and copper  
**B** copper and potassium  
**C** potassium and sodium  
**D** sodium and calcium
- 21 Polluted air contains toxic oxides of the elements carbon, C, and sulfur, S, emitted from car exhausts.

Which row in the table is correct?

	toxic oxide is acidic	toxic oxide formula is XO
<b>A</b>	C only	C only
<b>B</b>	C only	S only
<b>C</b>	S only	C only
<b>D</b>	S only	S only

22 The contents of the labelled beakers shown are mixed.

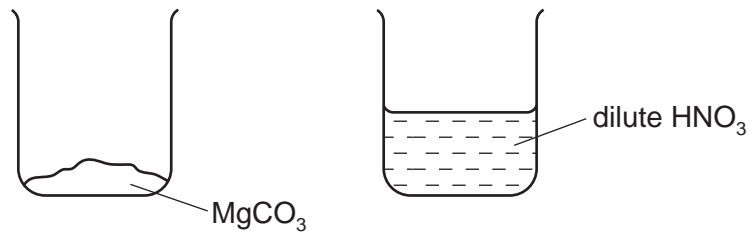

Which salt is formed?

- A magnesium nitrate
- B magnesium sulfate
- C manganese nitrate
- D manganese sulfate

23 Marble chips react with dilute hydrochloric acid as shown.



The progress of this reaction was followed using the apparatus shown.

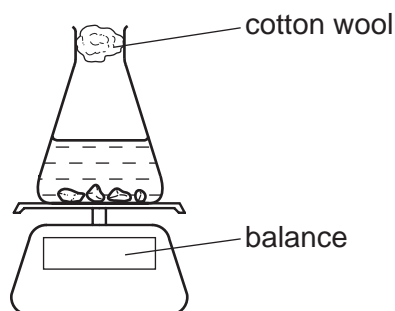

Which graph shows the results of this experiment?

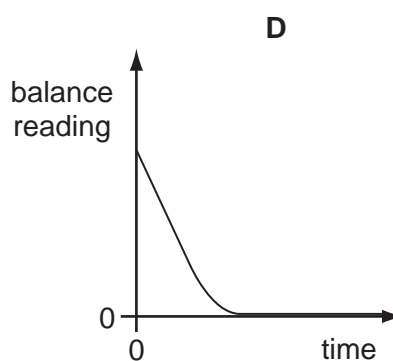
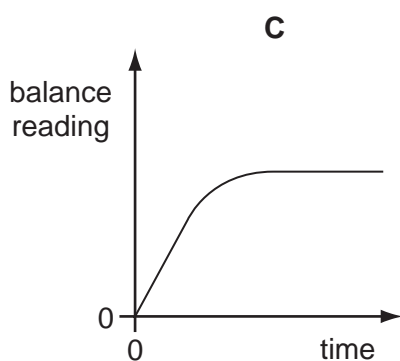
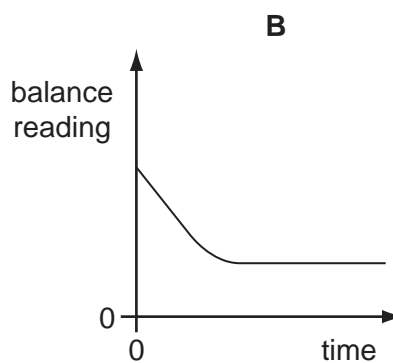
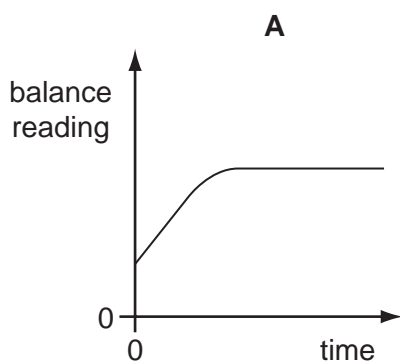

24 Testing for the gases chlorine, hydrogen and oxygen requires different methods.

For which gases is a splint used?

	$\text{Cl}_2$	$\text{H}_2$	$\text{O}_2$
<b>A</b>	✓	✓	✗
<b>B</b>	✓	✗	✗
<b>C</b>	✗	✓	✓
<b>D</b>	✗	✗	✓

- 25 Which equation shows the complete combustion of a hydrocarbon?
- A  $\text{C}_2\text{H}_4 + 2\text{O}_2 \rightarrow 2\text{CO} + 2\text{H}_2\text{O}$
  - B  $\text{C}_2\text{H}_4 + 3\text{O}_2 \rightarrow 2\text{CO}_2 + 2\text{H}_2\text{O}$
  - C  $\text{C}_2\text{H}_6\text{O} + 2\text{O}_2 \rightarrow 2\text{CO} + 3\text{H}_2\text{O}$
  - D  $\text{C}_2\text{H}_6\text{O} + 3\text{O}_2 \rightarrow 2\text{CO}_2 + 3\text{H}_2\text{O}$
- 26 How can the structure of a plastic be described?
- A a mixture of ions
  - B a mixture of long chain molecules
  - C a mixture of atoms of metals
  - D a mixture of small hydrocarbon molecules
- 27 Which property of the compounds in crude oil is used to separate the oil into useful fractions?
- A boiling point
  - B density
  - C melting point
  - D solubility
- 28 A car travels 100 km. The highest speed of the car is 90 km/h, and the lowest speed is 30 km/h. The journey takes two hours.
- What is the average speed for the journey?
- A 30 km/h      B 50 km/h      C 60 km/h      D 90 km/h
- 29 Which items of apparatus are required to determine the density of a liquid?
- A balance and measuring cylinder
  - B balance and thermometer
  - C metre rule and measuring cylinder
  - D metre rule and thermometer
- 30 Which property of an object **cannot** be changed by a force?
- A its mass
  - B its motion
  - C its shape
  - D its size

- 31 A wooden plank rests in equilibrium on two boulders on opposite sides of a narrow stream. Three forces of size P, Q and R act on the plank.

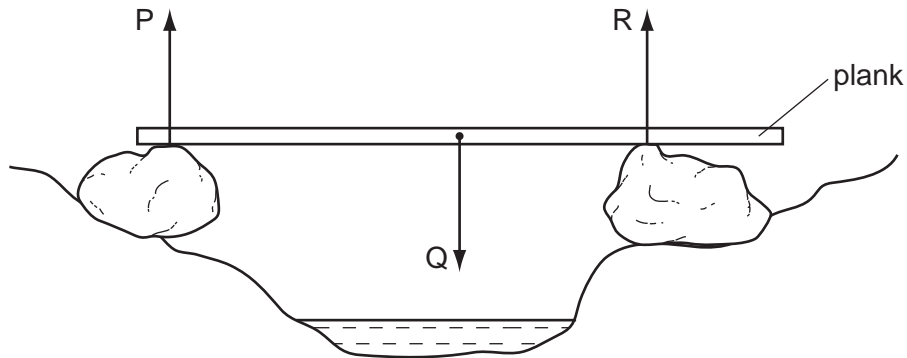

How are the sizes of the forces related?

- A  $P + Q = R$   
 B  $P + R = Q$   
 C  $P = Q = R$   
 D  $P = Q + R$
- 32 Electricity can be obtained from different energy resources.  
 Which energy resource is used to obtain electricity without producing heat to boil water?
- A coal  
 B gas  
 C hydroelectric  
 D nuclear
- 33 A rod is made up of copper and wood joined together.  
 After the rod is heated at the join in the centre for about a minute, where would the lowest temperature be?

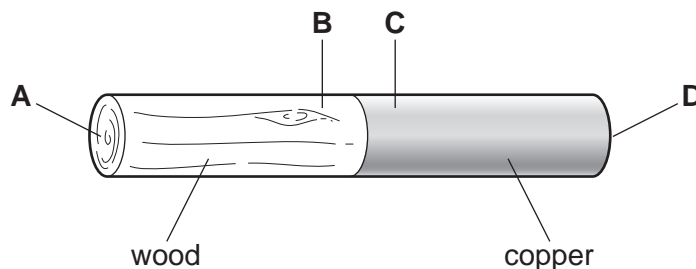

- 34 A hot water tank is fitted with two identical heaters P and Q. Heater P is two thirds of the way up the tank and heater Q is at the very bottom. The tank is full of cold water.

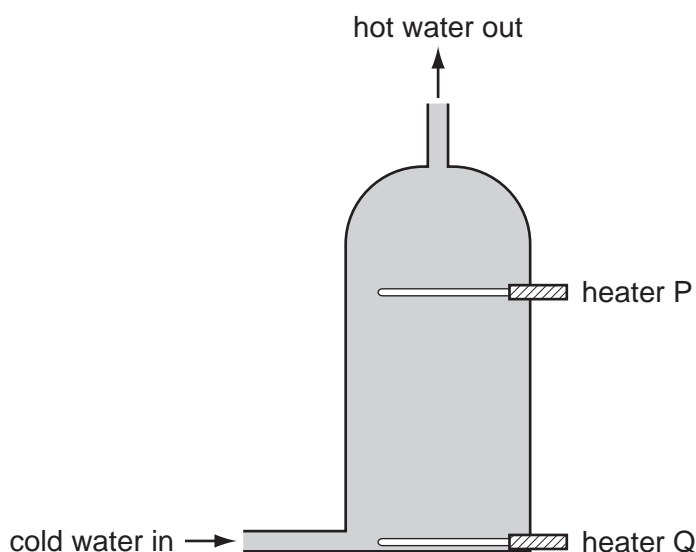

When only heater Q is switched on, it takes a very long time to heat the tank of water to the required temperature of  $60^{\circ}\text{C}$ .

What happens to the tank of cold water if only heater P is switched on?

- A All the water reaches  $60^{\circ}\text{C}$  in less time than before.
  - B All the water reaches  $60^{\circ}\text{C}$  in the same time as before.
  - C The bottom two thirds of the water reaches  $60^{\circ}\text{C}$  in two thirds of the original time
  - D The top one third of the water reaches  $60^{\circ}\text{C}$  in one third of the original time.
- 35 The diagram shows the path of a ray of light passing through the principal focus F of a lens.

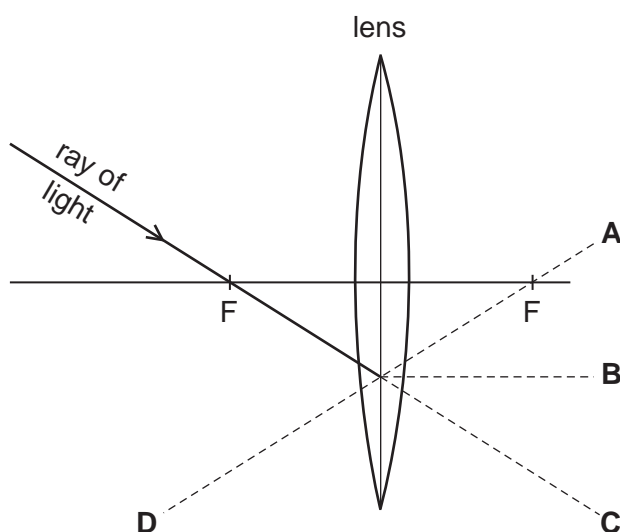

- 36 Using the circuit shown, the current  $I$  is found for various voltages  $V$ . The temperature of the resistor does not change.

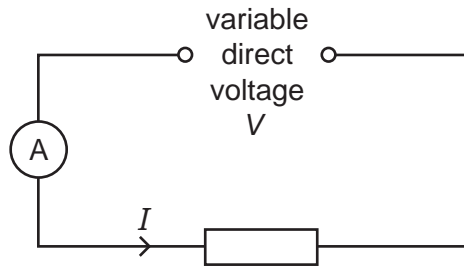

Which graph shows the results obtained?

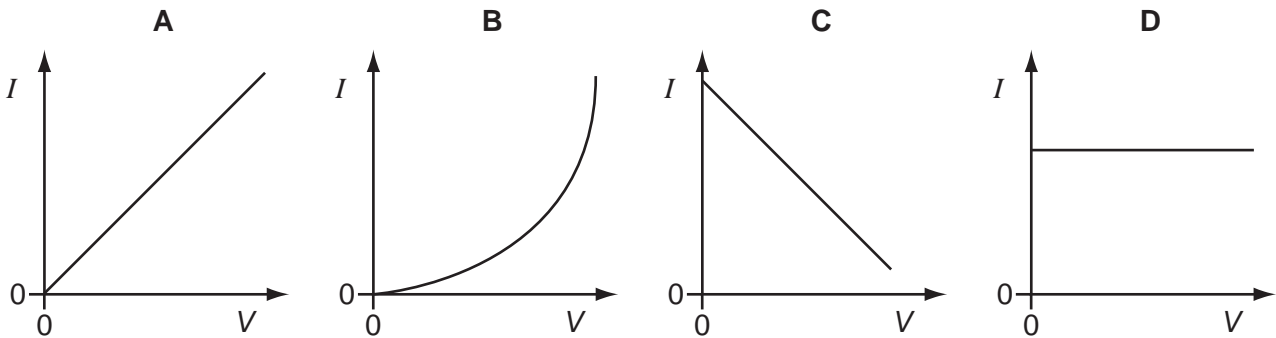

- 37 In the circuit shown, ammeter X reads 0.5 A.

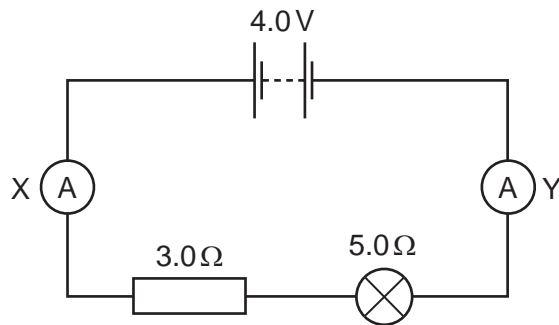

What does ammeter Y read?

- A** 0                      **B** 0.5 A                      **C** 3.5 A                      **D** 4.0 A

38 In the circuits shown, all the resistors are identical.

Which circuit has the **least** resistance?

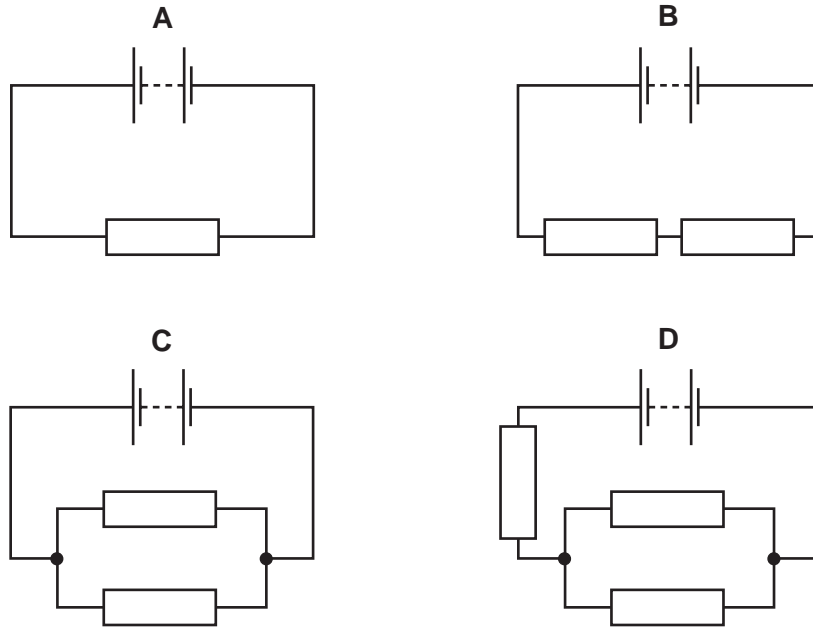

39 In the circuit below, one of the lamps breaks, causing all the other lamps to go out.

Which lamp breaks?

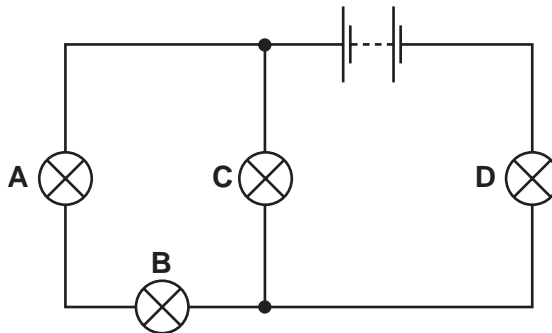

40 A transformer has 50 turns on its primary coil and 100 turns on its secondary coil. An alternating voltage of 25.0V is connected across the primary coil.

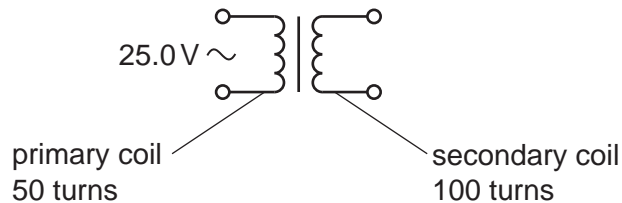

What is the voltage across the secondary coil?

- A** 12.5V      **B** 50.0V      **C** 175V      **D** 200V







**BLANK PAGE**

**DATA SHEET**  
**The Periodic Table of the Elements**

		Group																																																																		
I	II	III	IV	V	VI	VII	O																																																													
7 <b>Li</b> Lithium 3	9 <b>Be</b> Beryllium 4	1 <b>H</b> Hydrogen 1	11 <b>B</b> Boron 5	12 <b>C</b> Carbon 6	14 <b>N</b> Nitrogen 7	16 <b>O</b> Oxygen 8	19 <b>F</b> Fluorine 9	20 <b>Ne</b> Neon 10	23 <b>Na</b> Sodium 11	24 <b>Mg</b> Magnesium 12	27 <b>Al</b> Aluminium 13	28 <b>Si</b> Silicon 14	31 <b>P</b> Phosphorus 15	32 <b>S</b> Sulfur 16	35.5 <b>Cl</b> Chlorine 17	40 <b>Ar</b> Argon 18	39 <b>K</b> Potassium 19	40 <b>Ca</b> Calcium 20	45 <b>Sc</b> Scandium 21	48 <b>Ti</b> Titanium 22	51 <b>V</b> Vanadium 23	52 <b>Cr</b> Chromium 24	55 <b>Mn</b> Manganese 25	56 <b>Fe</b> Iron 26	59 <b>Co</b> Cobalt 27	59 <b>Ni</b> Nickel 28	64 <b>Cu</b> Copper 29	65 <b>Zn</b> Zinc 30	70 <b>Ga</b> Gallium 31	73 <b>Ge</b> Germanium 32	75 <b>As</b> Arsenic 33	79 <b>Se</b> Selenium 34	80 <b>Br</b> Bromine 35	84 <b>Kr</b> Krypton 36	85 <b>Rb</b> Rubidium 37	88 <b>Sr</b> Strontium 38	89 <b>Y</b> Yttrium 39	91 <b>Zr</b> Zirconium 40	93 <b>Nb</b> Niobium 41	96 <b>Mo</b> Molybdenum 42	101 <b>Ru</b> Ruthenium 44	106 <b>Pd</b> Palladium 46	112 <b>Cd</b> Cadmium 48	115 <b>In</b> Indium 49	119 <b>Sn</b> Tin 50	122 <b>Sb</b> Antimony 51	127 <b>I</b> Iodine 53	131 <b>Xe</b> Xenon 54	133 <b>Cs</b> Caesium 55	137 <b>Ba</b> Barium 56	139 <b>La</b> Lanthanum 57	178 <b>Hf</b> Hafnium 72	181 <b>Ta</b> Tantalum 73	184 <b>W</b> Tungsten 74	190 <b>Os</b> Osmium 76	192 <b>Ir</b> Iridium 77	195 <b>Pt</b> Platinum 78	197 <b>Au</b> Gold 79	201 <b>Hg</b> Mercury 80	204 <b>Tl</b> Thallium 81	207 <b>Pb</b> Lead 82	209 <b>Bi</b> Bismuth 83	210 <b>Po</b> Polonium 84	210 <b>At</b> Astatine 85	210 <b>Rn</b> Radon 86	226 <b>Ra</b> Radium 88	227 <b>Ac</b> Actinium 89	†
												140 <b>Ce</b> Cerium 58	141 <b>Pr</b> Praseodymium 59	144 <b>Nd</b> Neodymium 60	150 <b>Sm</b> Samarium 62	152 <b>Eu</b> Europium 63	157 <b>Gd</b> Gadolinium 64	159 <b>Tb</b> Terbium 65	162 <b>Dy</b> Dysprosium 66	165 <b>Ho</b> Holmium 67	167 <b>Er</b> Erbium 68	169 <b>Tm</b> Thulium 69	173 <b>Yb</b> Ytterbium 70	175 <b>Lu</b> Lutetium 71	232 <b>Th</b> Thorium 90	238 <b>U</b> Uranium 92	238 <b>Pa</b> Protactinium 91	238 <b>Np</b> Neptunium 93	238 <b>Pu</b> Plutonium 94	238 <b>Am</b> Americium 95	238 <b>Cm</b> Curium 96	238 <b>Bk</b> Berkelium 97	238 <b>Cf</b> Californium 98	238 <b>Es</b> Einsteinium 99	238 <b>Fm</b> Fermium 100	238 <b>Md</b> Mendelevium 101	238 <b>No</b> Nobelium 102	238 <b>Lr</b> Lawrencium 103																														

\*58-71 Lanthanoid series  
†90-103 Actinoid series

a	<b>X</b>	a = relative atomic mass
b	<b>X</b>	X = atomic symbol
		b = proton (atomic) number

The volume of one mole of any gas is 24 dm<sup>3</sup> at room temperature and pressure (r.t.p.).

Permission to reproduce items where third-party owned material protected by copyright is included has been sought and cleared where possible. Every reasonable effort has been made by the publisher (UCLES) to trace copyright holders, but if any items requiring clearance have unwittingly been included, the publisher will be pleased to make amends at the earliest possible opportunity.

University of Cambridge International Examinations is part of the Cambridge Assessment Group. Cambridge Assessment is the brand name of University of Cambridge Local Examinations Syndicate (UCLES), which is itself a department of the University of Cambridge.