

International General Certificate of Secondary Education
CAMBRIDGE INTERNATIONAL EXAMINATIONS

COMBINED SCIENCE

0653/1

PAPER 1 Multiple Choice

OCTOBER/NOVEMBER SESSION 2002

45 minutes

Additional materials:

Multiple Choice answer sheet

Soft clean eraser

Soft pencil (type B or HB is recommended)

TIME 45 minutes

INSTRUCTIONS TO CANDIDATES

Do not open this booklet until you are told to do so.

Write your name, Centre number and candidate number on the answer sheet in the spaces provided unless this has already been done for you.

There are **forty** questions in this paper. Answer **all** questions. For each question, there are four possible answers, **A, B, C** and **D**. Choose the **one** you consider correct and record your choice in **soft pencil** on the separate answer sheet.

Read very carefully the instructions on the answer sheet.

INFORMATION FOR CANDIDATES

Each correct answer will score one mark. A mark will not be deducted for a wrong answer.

Any rough working should be done in this booklet.

A copy of the Periodic Table is printed on page 20.

This question paper consists of 17 printed pages and 3 blank pages.



- 1 The diagram shows a root hair cell between soil particles.

By what process does water move into the cell?

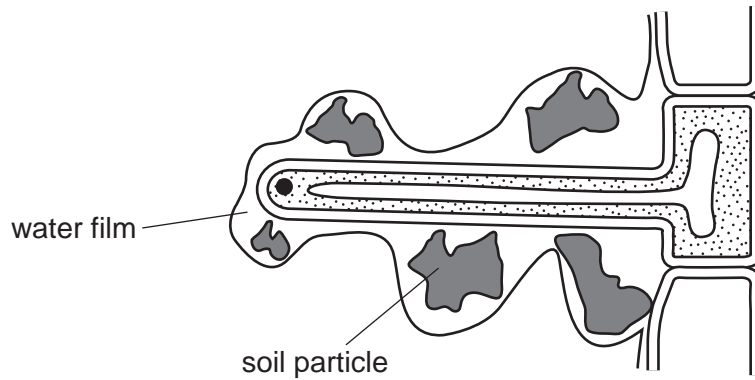

- A diffusion
 B excretion
 C respiration
 D secretion
- 2 The diagram shows an experiment to investigate the reaction of the enzyme catalase, which is found in raw potato.

3 cm³ of raw potato, cut as shown, is added to each jar.

Which balloon will be the first to inflate?

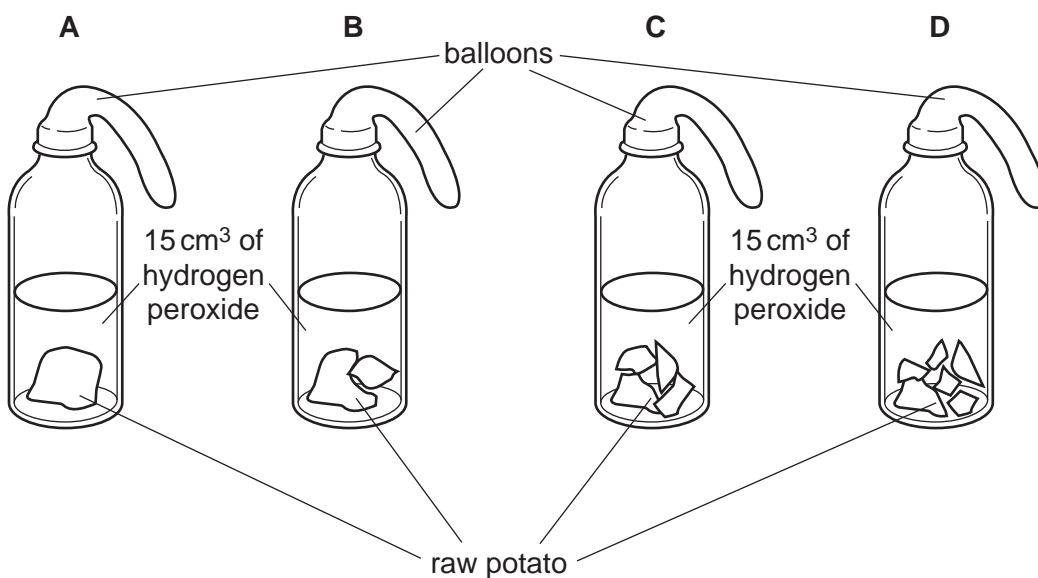

- 3 Plants manufacture their own supplies of carbohydrate.

What are the raw materials and waste products of this process?

	raw materials	waste product
A	carbon dioxide and chlorophyll	oxygen
B	carbon dioxide and water	oxygen
C	oxygen and chlorophyll	carbon dioxide
D	oxygen and water	carbon dioxide

- 4 The diagram shows a section through a leaf.

During photosynthesis, where would the greatest conversion of light energy to chemical energy take place?

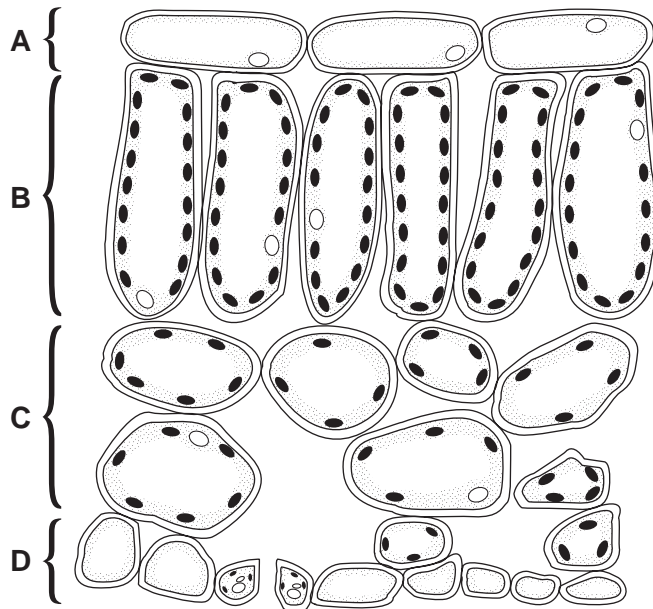

- 5 The diagram shows a section through a human tooth.

Which part contains blood vessels?

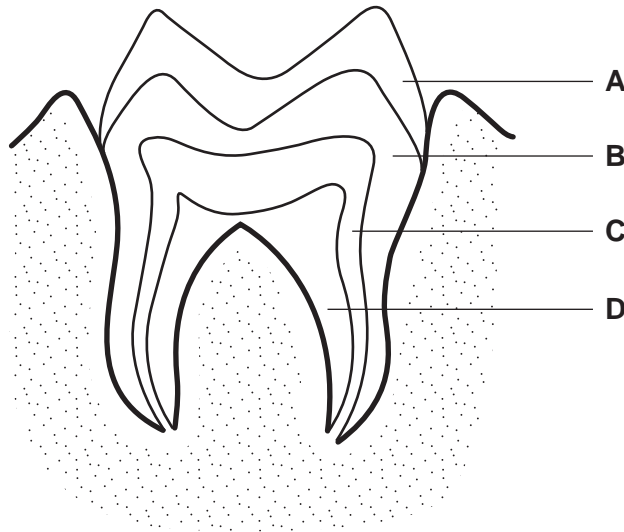

- 6 The table shows the results of tests carried out on a sample of food.

test	Benedict's	iodine	biuret
result	orange	brown	purple

Which nutrients are in the food?

- A protein and reducing sugar only
 - B protein and starch only
 - C protein, reducing sugar and starch
 - D reducing sugar and starch only
- 7 The diagram shows some structures in the human thorax (chest).
- Into which part does carbon dioxide pass immediately after leaving the blood?

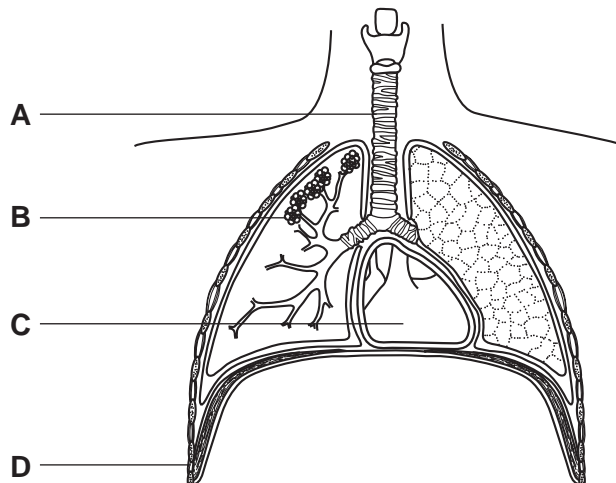

8 Which diagram shows a red blood cell?

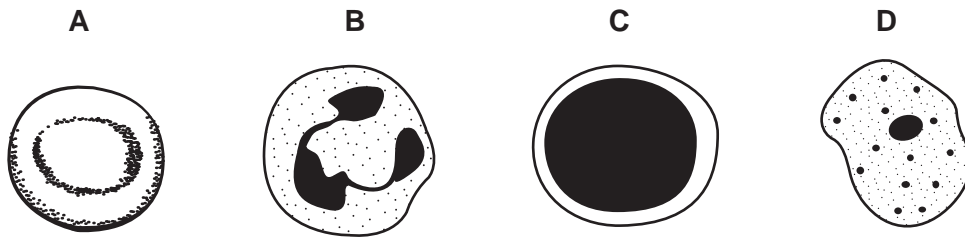

9 The diagram represents the human blood system.

Which part of the heart is the left ventricle?

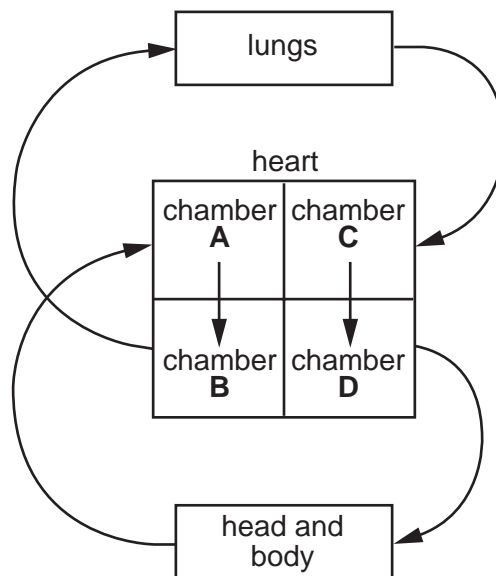

10 In which part of a plant does water normally change from liquid into vapour?

- A mesophyll
- B phloem
- C root hair
- D xylem

11 Where is insulin produced and where does it have its main effect?

	insulin produced	main effect
A	liver	small intestine
B	pancreas	liver
C	small intestine	stomach
D	stomach	pancreas

12 The diagram shows a fetus developing inside a uterus.

Which arrow shows how viruses and drugs may enter the foetus?

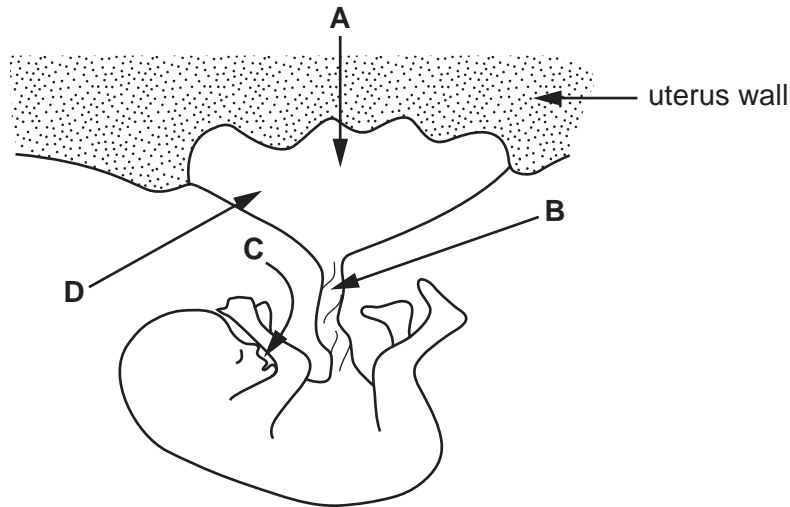

13 After a plant has produced flowers, what is the correct sequence of events leading to reproduction?

- A fertilisation, pollination, seed formation
- B pollination, fertilisation, seed formation
- C seed formation, fertilisation, pollination
- D seed formation, pollination, fertilisation

14 It is possible to grow plants that are genetically identical.

What are plants grown in this way called?

- A clones
- B gametes
- C varieties
- D zygotes

15 The diagram shows a helium atom.

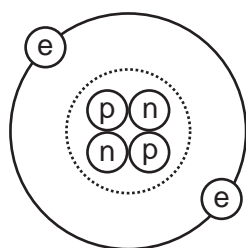

key

(p) proton

(n) neutron

(e) electron

(dotted circle) nucleus

Which particles in the helium atom have approximately the same mass?

- A (e) and (p) only
 B (e) and (n) only
 C (p) and (n) only
 D (e) and (p) and (n)

16 The table shows information about four different compounds.

Which compound contains ionic bonds?

	formula of compound	elements present in compound
A	CO ₂	carbon, oxygen
B	HCl	hydrogen, chlorine
C	NH ₃	nitrogen, hydrogen
D	Na ₂ O	sodium, oxygen

17 The diagram shows apparatus used for filtration.

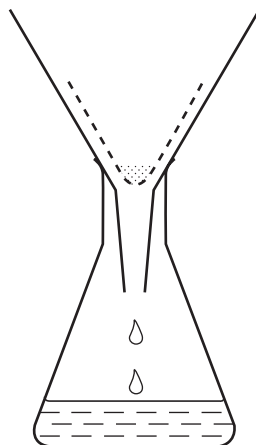

Why can sugar and salt **not** be separated by using this apparatus?

- A They are both solid.
- B They are both white.
- C They both dissolve in water.
- D They both have the same size particles.

18 The equations for the complete combustion of carbon and hydrogen are shown.

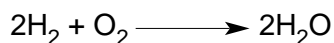

How many molecules of oxygen, O_2 , are needed for the complete combustion of 1 molecule of the hydrocarbon C_3H_8 ?

- A 2 B 5 C 7 D 11

19 A solid X is placed in the circuit shown. The lamp lights.

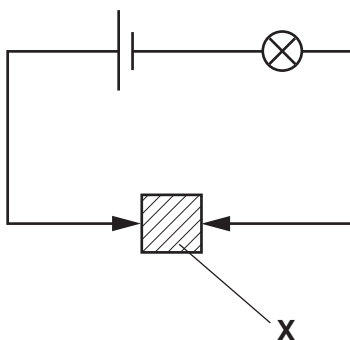

What is solid X?

- A an alloy
- B a compound
- C an electrolyte
- D a salt

20 Which of the following correctly compares iron with stainless steel?

		brittle	rusts
A	iron	x	✓
B	iron	✓	x
C	stainless steel	x	x
D	stainless steel	✓	x

21 A firework gives a bright flame in which yellow and red colours are seen.

Which two metals are present in the firework?

- A** calcium and copper
- B** copper and potassium
- C** potassium and sodium
- D** sodium and calcium

22 Potassium is a very reactive metal.

How is potassium obtained from its ore?

- A** by oxidation using air
- B** by oxidation using coke
- C** by reduction using coke
- D** by reduction using electrolysis

23 The table shows the properties of four substances.

Which substance could be an alkali?

	solubility in water	reaction with an acid
A	insoluble	reacts
B	insoluble	does not react
C	soluble	reacts
D	soluble	does not react

- 24 The diagrams show the steps in two industrial processes, X and Y, to produce pure products. In one step in one process, electrolysis is used.

Which step is this?

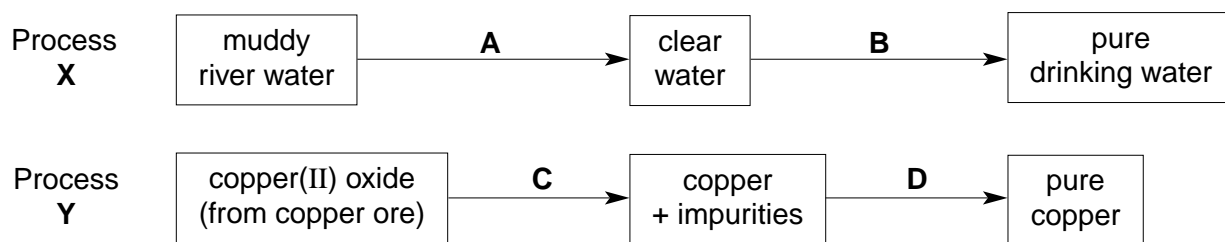

- 25 The diagram shows how to test the products of complete combustion of Calor gas (a hydrocarbon fuel).

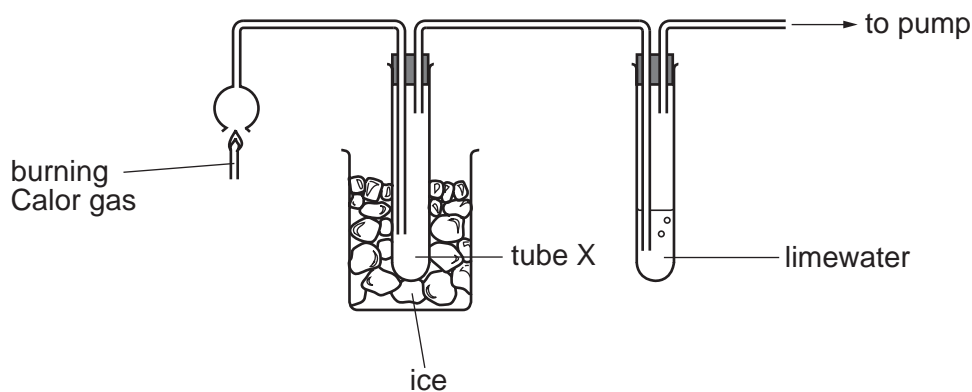

The limewater turns cloudy.

What is collected in tube X?

- A a liquid that boils at 100 °C
 - B a liquid that burns easily
 - C particles of carbon
 - D solid carbon dioxide
- 26 Coal, hydrogen, methane and gasoline (petrol) are commonly used as fuels.

How many of these fuels are solids, liquids or gases?

	solids	liquids	gases
A	0	2	2
B	1	1	2
C	2	1	1
D	2	2	0

27 Crude oil (petroleum) is heated, using the apparatus shown.

Four fractions, with different boiling point ranges, are collected.

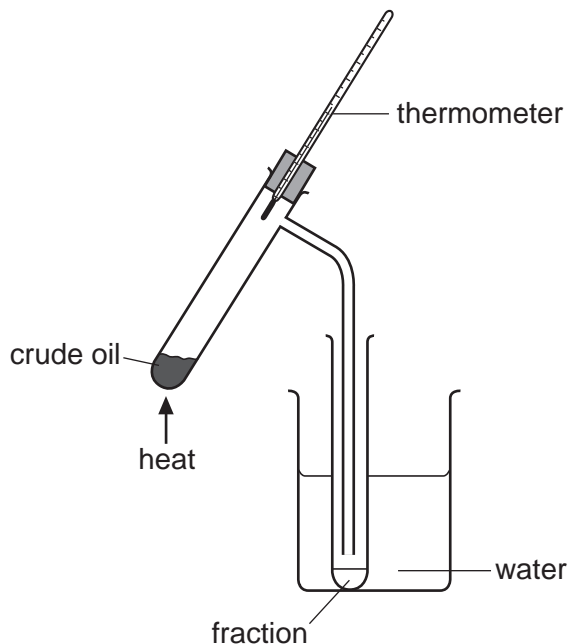

Which term best describes crude oil?

- A a compound
 - B an element
 - C a mixture
 - D a plastic
- 28 A girl uses a rule to measure the length of a metal rod. Because the end of the rule is damaged, she places one end of the rod at the 1 cm mark as shown.

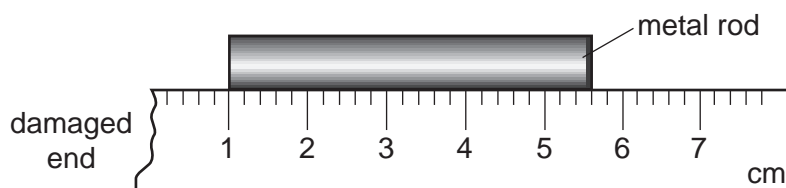

How long is the metal rod?

- A 43 mm
- B 46 mm
- C 53 mm
- D 56 mm

- 29 A child is standing on the platform of a station, watching the trains.



A train travelling at 30 m/s takes 3 s to pass the child.

What is the length of the train?

- A 10 m B 30 m C 90 m D 270 m
- 30 Which of the following statements is correct?
- A Mass and weight are different names for the same thing.
- B The mass of an object is different if the object is taken to the Moon.
- C The weight of a car is one of the forces acting on the car.
- D The weight of a chocolate bar is measured in kilograms.
- 31 The masses of a measuring cylinder before and after pouring some liquid are shown in the diagram.

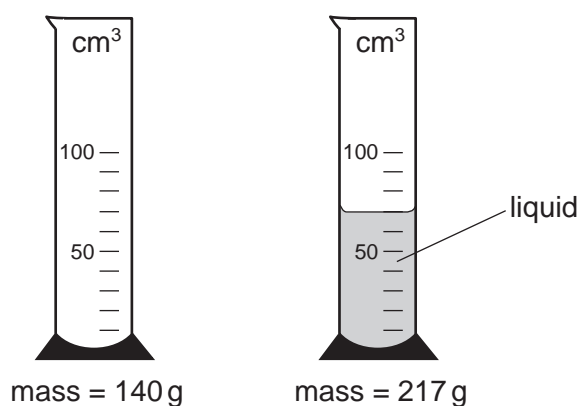

What is the density of the liquid?

- A $\frac{217}{52}$ g/cm³ B $\frac{217}{70}$ g/cm³ C $\frac{77}{52}$ g/cm³ D $\frac{77}{70}$ g/cm³

32 In which of these situations is no resultant force needed?

- A a car changing direction
- B a car moving in a straight line at a steady speed
- C a car slowing down
- D a car speeding up

33 In a car engine, energy stored in the fuel is converted into thermal energy (heat energy) and energy of motion (kinetic energy).

In which form is the energy stored in the fuel?

- A chemical
- B geothermal
- C hydroelectric
- D nuclear

34 How does thermal energy (heat energy) travel through the vacuum between the Earth and the Sun?

- A by conduction
- B by convection
- C by radiation
- D by radioactive decay

- 35 Two plastic cups are placed one inside the other. Hot water is poured into the inner cup and a lid is put on top as shown.

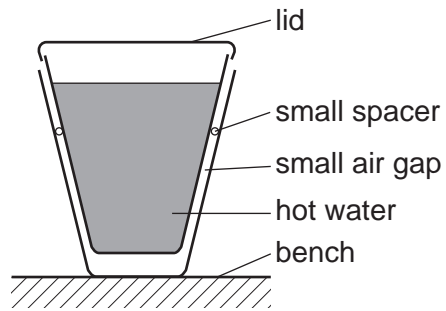

Which statement is correct?

- A Heat loss by radiation is prevented by the small air gap.
 - B No heat passes through the sides of either cup.
 - C The bench is heated by convection from the bottom of the outer cup.
 - D The lid is used to reduce heat loss by convection.
- 36 A student looks at the letter P on a piece of paper, and at its reflection in a mirror.

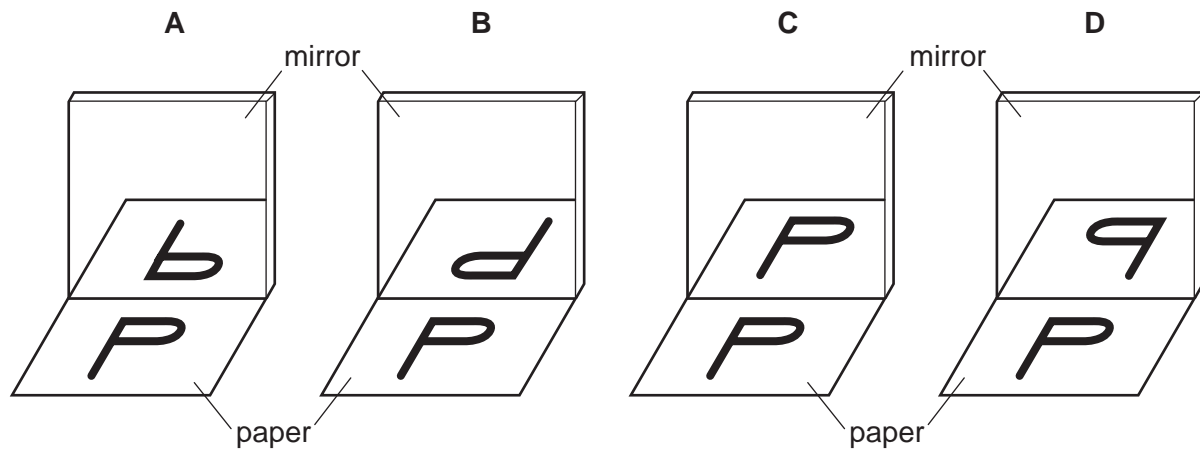

37 In which circuit does the ammeter read the total current through both resistors?

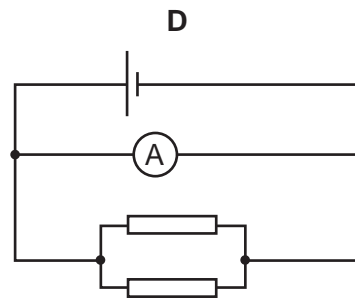
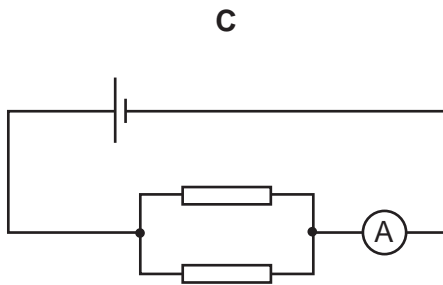
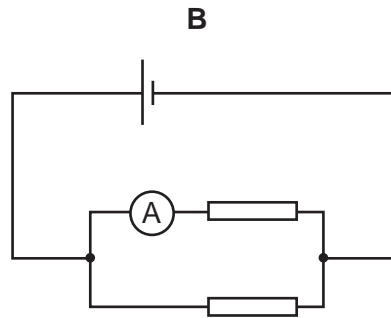
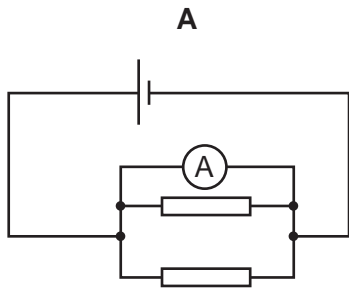

38 The table shows the voltage and current ratings for four light bulbs.

Which bulb has the greatest resistance when used normally?

	voltage / V	current / A
A	2	0.5
B	3	0.2
C	6	12
D	12	1.0

- 39 The diagram shows a circuit, with four possible positions to place a switch.

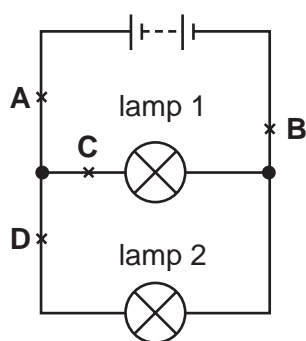

At which labelled point should a switch be placed so that lamp 1 remains on all the time and lamp 2 can be switched on and off?

- 40 A radioactive source emits radiation that can pass through a sheet of paper but not through thick aluminium.

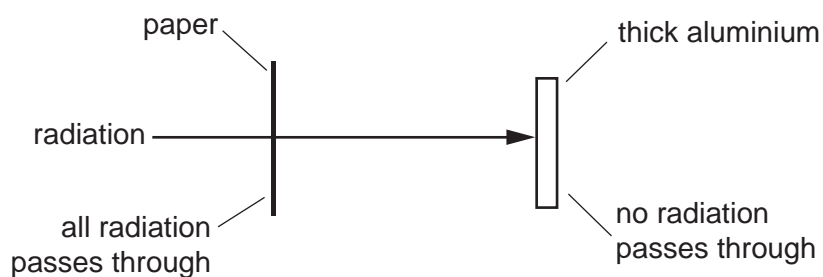

What does this show about the radiation?

- A It is alpha-particles.
- B It is beta-particles.
- C It is gamma-rays.
- D It is a mixture of alpha-particles and gamma-rays.

DATA SHEET

The Periodic Table of the Elements

		Group											
I	II	III	IV	V	VI	VII	O						
		1 H Hydrogen 1										4 He Helium 2	
7 Li Lithium 3	9 Be Beryllium 4											20 Ne Neon 10	
23 Na Sodium 11	24 Mg Magnesium 12											35.5 Cl Chlorine 17	
39 K Potassium 19	40 Ca Calcium 20	51 V Vanadium 23	52 Cr Chromium 24	55 Mn Manganese 25	56 Fe Iron 26	59 Co Cobalt 27	59 Ni Nickel 28	64 Cu Copper 29	65 Zn Zinc 30	73 Ge Germanium 32	75 As Arsenic 33	79 Se Selenium 34	84 Kr Krypton 36
85 Rb Rubidium 37	88 Sr Strontium 38	91 Zr Zirconium 40	96 Mo Molybdenum 42	101 Ru Ruthenium 44	103 Rh Rhodium 45	106 Pd Palladium 46	108 Ag Silver 47	112 Cd Cadmium 48	115 In Indium 49	119 Sn Tin 50	122 Sb Antimony 51	128 Te Tellurium 52	131 Xe Xenon 54
133 Cs Caesium 55	137 Ba Barium 56	181 Ta Tantalum 73	184 W Tungsten 74	186 Re Rhenium 75	190 Os Osmium 76	192 Ir Iridium 77	195 Pt Platinum 78	197 Au Gold 79	204 Tl Thallium 81	207 Pb Lead 82	209 Bi Bismuth 83	210 Po Polonium 84	210 Rn Radon 86
87 Fr Francium	226 Ra Radium	227 Ac Actinium											88
*58-71 Lanthanoid series													175 Lu Lutetium 71
†90-103 Actinoid series													103 Lr Lawrencium

Key

a	X
b	

a = relative atomic mass
 X = atomic symbol
 b = proton (atomic) number

The volume of one mole of any gas is 24 dm³ at room temperature and pressure (r.t.p.).