



UNIVERSITY OF CAMBRIDGE INTERNATIONAL EXAMINATIONS
International General Certificate of Secondary Education

www.XtremePapers.com

COMBINED SCIENCE

0653/01

Paper 1 Multiple Choice

October/November 2009

45 minutes

Additional Materials: Multiple Choice Answer Sheet
Soft clean eraser
Soft pencil (type B or HB is recommended)

* 1 5 7 4 9 6 9 5 9 0 *

READ THESE INSTRUCTIONS FIRST

Write in soft pencil.

Do not use staples, paper clips, highlighters, glue or correction fluid.

Write your name, Centre number and candidate number on the Answer Sheet in the spaces provided unless this has been done for you.

There are **forty** questions on this paper. Answer **all** questions. For each question there are four possible answers **A, B, C** and **D**.

Choose the **one** you consider correct and record your choice in **soft pencil** on the separate Answer Sheet.

Read the instructions on the Answer Sheet very carefully.

Each correct answer will score one mark. A mark will not be deducted for a wrong answer.

Any rough working should be done in this booklet.

A copy of the Periodic Table is printed on page 20.

This document consists of **19** printed pages and **1** blank page.



1 The diagram shows a plant cell.

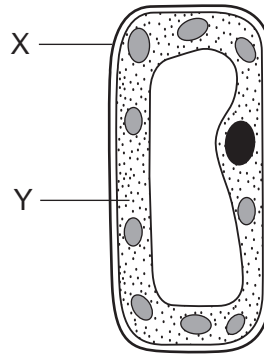

Which are represented by X and Y?

	X	Y
A	cell membrane	cell wall
B	cell membrane	cytoplasm
C	cell wall	cytoplasm
D	cell wall	cell membrane

2 Which substance can enter a living cell by diffusion?

- A** carbon dioxide
- B** cellulose
- C** protein
- D** starch

3 Which part of blood contains haemoglobin?

- A** plasma
- B** platelets
- C** red blood cells
- D** white blood cells

4 The diagram shows some cells in a leaf of a green plant.

In which layer of cells does most photosynthesis occur?

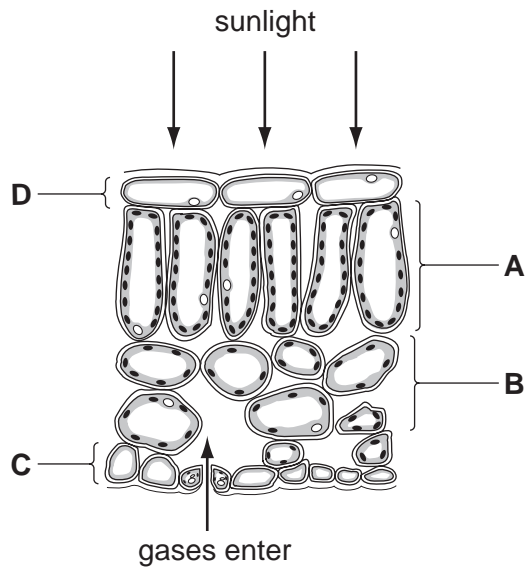

5 What is the **main** function of the front teeth?

- A crushing
- B cutting
- C grinding
- D tearing

- 6 The diagram shows apparatus at the start of a breathing experiment.

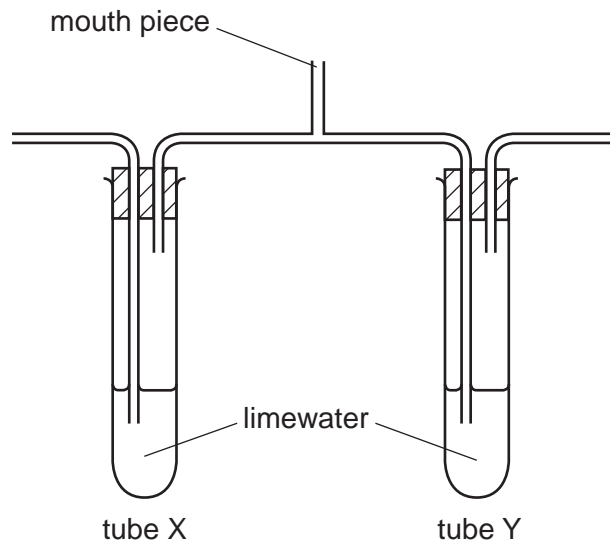

A person breathes in and out through the mouth piece for a short time.

Which row in the table shows the results?

	limewater in tube X	limewater in tube Y
A	goes cloudy	goes cloudy
B	goes cloudy	stays clear
C	stays clear	goes cloudy
D	stays clear	stays clear

- 7 What is the correct sequence when the nervous system responds to a stimulus?

- A** stimulus → central nervous system → receptor → effector → response
- B** stimulus → effector → central nervous system → receptor → response
- C** stimulus → effector → receptor → central nervous system → response
- D** stimulus → receptor → central nervous system → effector → response

- 8 Which cells are produced by fertilisation?

- A** gametes that are genetically different from the parents
- B** gametes that are genetically identical to the parents
- C** zygotes that are genetically different from the parents
- D** zygotes that are genetically identical to the parents

9 The diagram shows a developing fetus.

Where does gaseous exchange between the fetus and its mother occur?

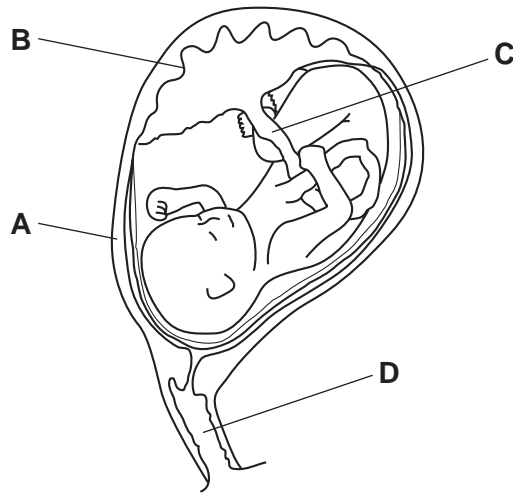

10 The diagram shows a flower just before fertilisation.

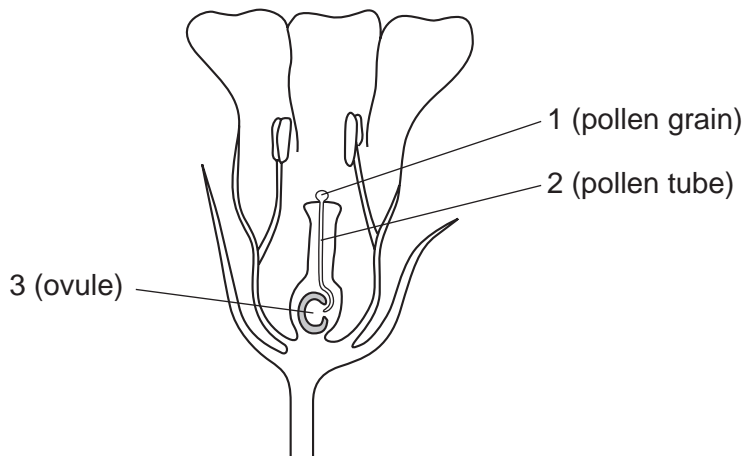

Where are the male and female gametes?

	male gamete	female gamete
A	1	3
B	2	3
C	3	1
D	3	2

- 11** In an experiment the tails of two mice were cut off before mating. The tails of their offspring were also removed before they produced offspring. This was repeated for many generations. All the offspring had tails when they were born.

Why were mice always born with tails?

- A** Asexual reproduction does not produce new varieties.
 - B** Genes are not passed on from parents to offspring.
 - C** The results of asexual reproduction are not predictable.
 - D** Variation due to the environment is not inherited.
- 12** What describes a population?
- A** all the animals and plants in a community
 - B** all the animals in a community
 - C** all members of the same species in a community
 - D** all the plants in a community

- 13** Tropical rainforests have a high species diversity.

What does this mean?

- A** Each species in the rainforest depends on many other species.
 - B** Each species in the rainforest shows great variation.
 - C** Rainforests contain large numbers of organisms.
 - D** Rainforests contain many different types of organisms.
- 14** Two liquids are separated by fractional distillation.
- This is possible because the liquids differ in their
- A** colour.
 - B** density.
 - C** solubility in water.
 - D** boiling point.

15 An atom has the symbol ${}^{12}_6\text{X}$.

Which diagram shows the arrangement of the electrons in this atom?

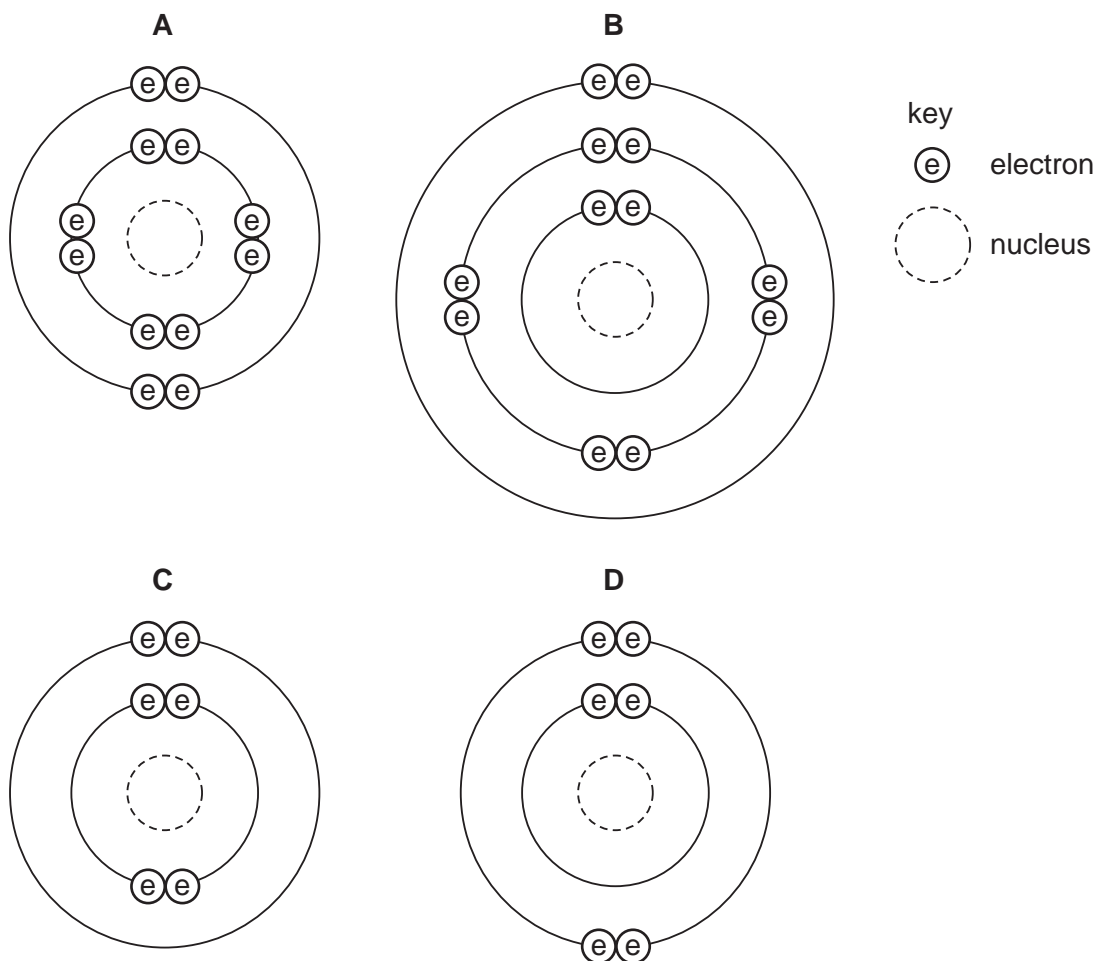

16 The atoms of three elements have the symbols ${}_8\text{X}$, ${}_9\text{Y}$ and ${}_{10}\text{Z}$.

Which types of bond form between these elements?

	X and Y	Y and Z
A	covalent	covalent
B	covalent	none
C	ionic	ionic
D	ionic	none

17 The diagram shows an outline of the Periodic Table.

Which two elements have similar chemical properties?

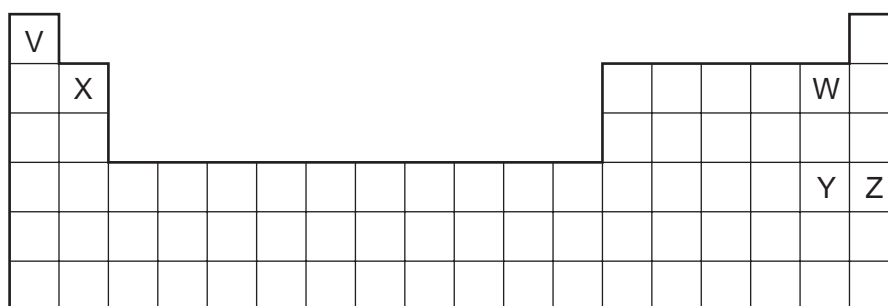

- A** V and W **B** V and X **C** W and Y **D** Y and Z

18 How many atoms of metals and of non-metals are shown in the formula Na_2SO_4 ?

	atoms of metals	atoms of non-metals
A	1	1
B	1	2
C	2	4
D	2	5

19 The diagram shows an experiment on the rusting of iron.

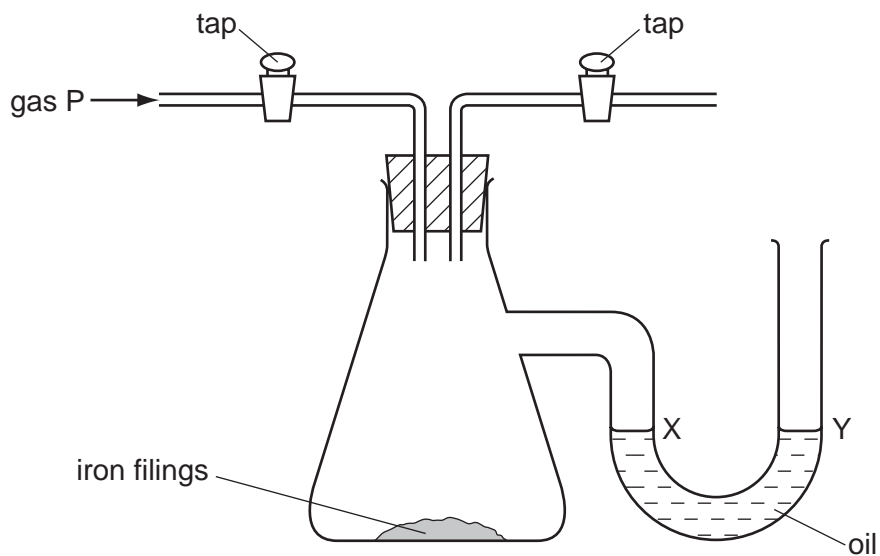

The vessel is filled with gas P, the taps are closed and the apparatus is then left for a week.

The experiment is repeated four times with different gases. Any pressure change is shown by changes in the oil levels X and Y.

Which pressure change occurs?

	gas P	pressure change
A	damp nitrogen	increase
B	damp oxygen	decrease
C	dry nitrogen	decrease
D	dry oxygen	increase

20 The diagram shows the result of a flame test.

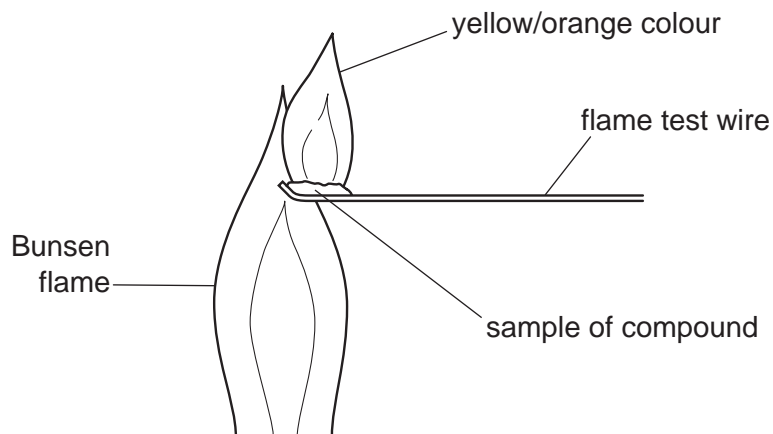

Which element is present in the compound?

- A silicon
 - B silver
 - C sodium
 - D sulfur
- 21 Which gas, present in the exhaust gases from a motor car, is **not** a pollutant?
- A carbon monoxide
 - B nitrogen
 - C nitrogen oxide
 - D sulfur dioxide
- 22 The Group II element strontium, Sr, is above calcium in the reactivity series.

Which of the substances shown in the table react with dilute hydrochloric acid to form a flammable gas?

	strontium powder	strontium oxide	strontium hydroxide	strontium carbonate
A	✓	✓	✓	✗
B	✓	✗	✗	✓
C	✓	✗	✗	✗
D	✗	✗	✗	✓

- 23 The solid line on the graph shows the volume of gas given off as calcium carbonate reacts with dilute hydrochloric acid.

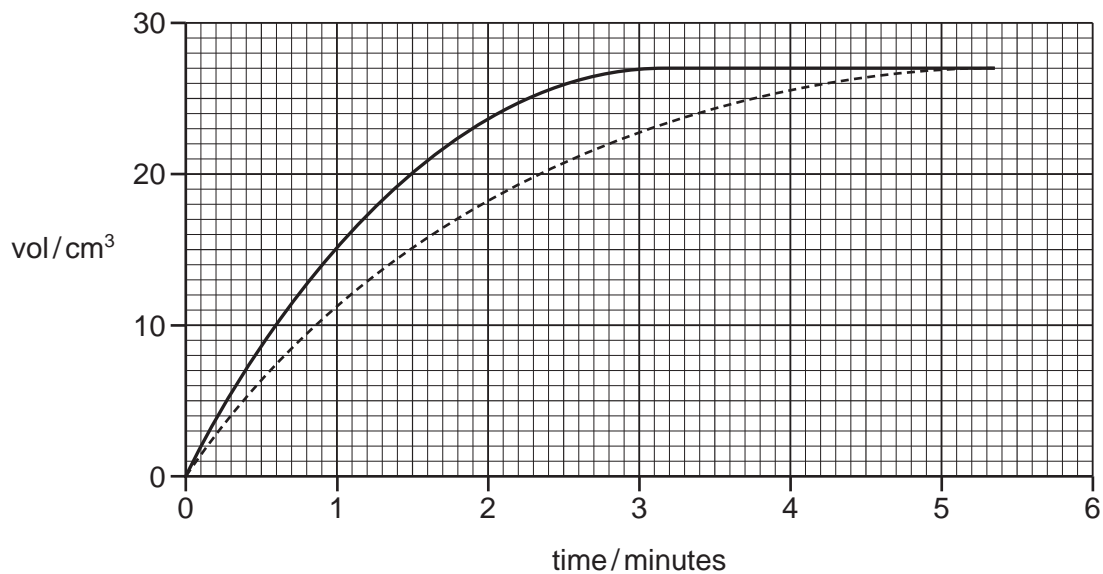

Which change to the conditions gives the results shown by the dotted line?

- A Decrease the temperature of the acid.
 - B Decrease the size of the calcium carbonate pieces.
 - C Increase the concentration of the acid.
 - D Increase the mass of the calcium carbonate pieces.
- 24 Which element is purified by using electrolysis?

- A chlorine
- B copper
- C iron
- D zinc

25 A hydrocarbon fuel is burned completely.



What are the products of this reaction?

	X	Y
A	CO	H ₂
B	CO	H ₂ O
C	CO ₂	H ₂
D	CO ₂	H ₂ O

26 Simple hydrocarbons are used to make plastics.

Which terms apply to these simple hydrocarbons?

	the bonds in their molecules are	they are called
A	covalent	monomers
B	covalent	polymers
C	ionic	monomers
D	ionic	polymers

27 Which statement defines a hydrocarbon?

- A** a compound that burns to form carbon dioxide and water
- B** a compound that contains carbon and hydrogen only
- C** a compound that is contained in fossil fuels
- D** a compound that only contains single bonds

- 28 A stopwatch is used to time an athlete running 100 m. The timekeeper forgets to reset the watch to zero before using it to time another athlete running 100 m.

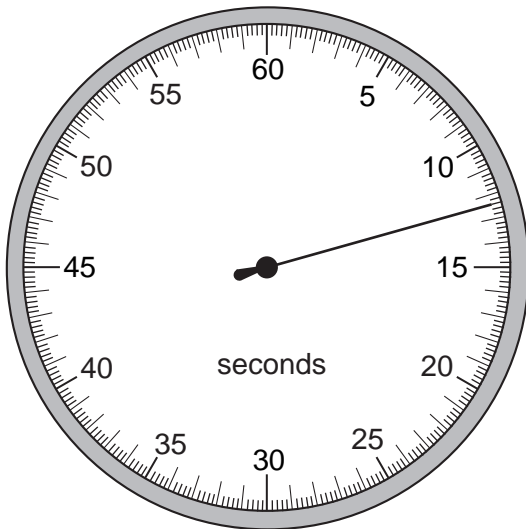

stopwatch at
end of first
athlete's run

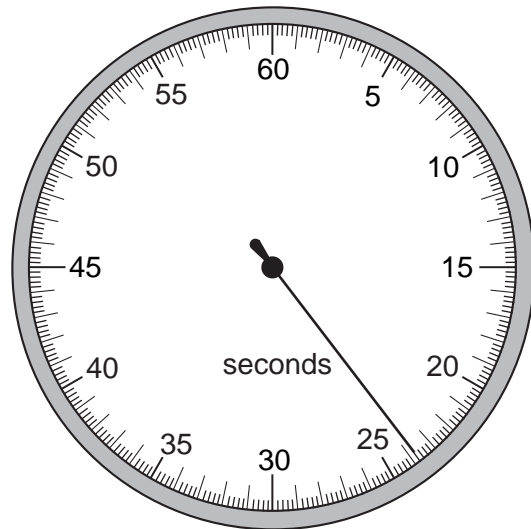

stopwatch at
end of second
athlete's run

How long does the second athlete take to run 100 m?

- A** 11.2 s **B** 11.4 s **C** 12.4 s **D** 23.8 s
- 29 Which property of a body can be measured in newtons?
- A** density
B mass
C volume
D weight

- 30 The diagrams show a rectangular box with inside measurements of 5 cm × 6 cm × 4 cm.

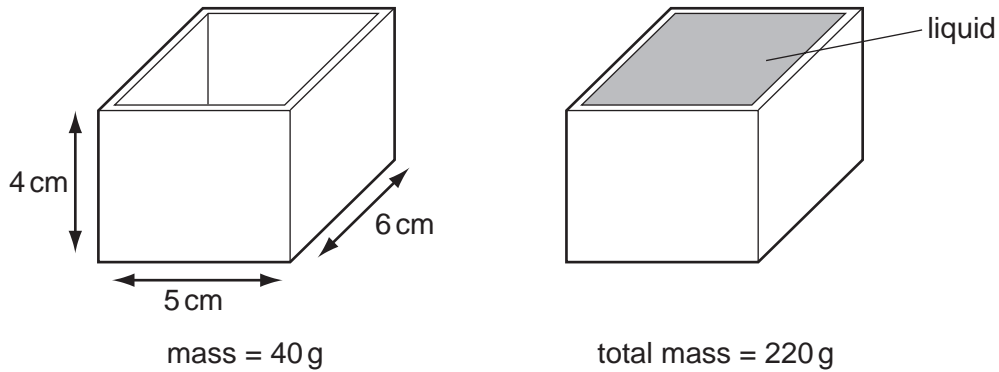

The box has a mass of 40 g when empty. When filled with a liquid it has a total mass of 220 g.

What is the density of the liquid?

- A $\frac{220}{(5 \times 6 \times 4)} \text{ g/cm}^3$
- B $\frac{(220 - 40)}{(5 \times 6 \times 4)} \text{ g/cm}^3$
- C $\frac{(5 \times 6 \times 4)}{220} \text{ g/cm}^3$
- D $\frac{(5 \times 6 \times 4)}{(220 - 40)} \text{ g/cm}^3$
- 31 The object in the diagram is acted upon by the two forces shown.

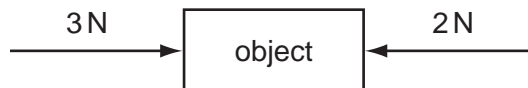

What is the effect of these forces?

- A The object moves to the left with constant speed.
- B The object moves to the left with constant acceleration.
- C The object moves to the right with constant speed.
- D The object moves to the right with constant acceleration.

32 A beaker contains water at room temperature.

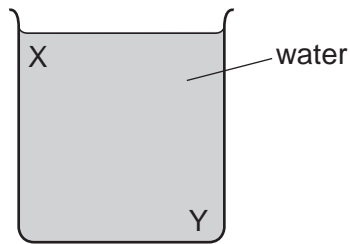

How could a convection current be set up in the water?

- A cool the water at X
- B cool the water at Y
- C stir the water at X
- D stir the water at Y

33 The drawing shows a wave.

Which labelled distance is the wavelength?

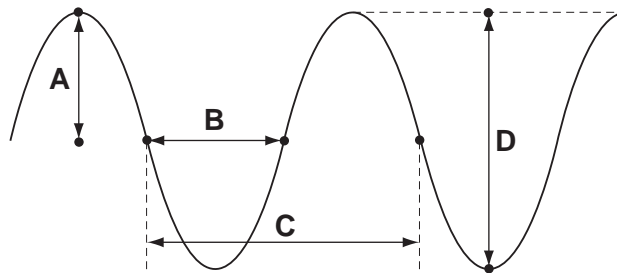

34 An object O is placed in front of a converging lens of focal length f .

At which point will the top of the image be seen?

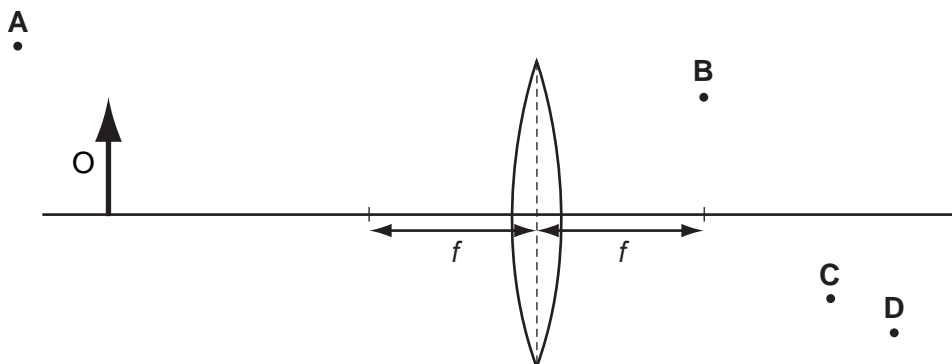

35 A pupil measures the potential difference across a device and the current in it.

Which calculation gives the resistance of the device?

- A current + potential difference
- B current \div potential difference
- C potential difference \div current
- D potential difference \times current

36 The diagram shows a battery connected to two identical resistors. Three ammeters M_1 , M_2 and M_3 are connected in the circuit.

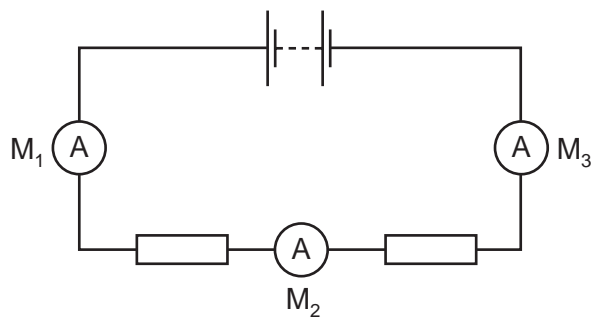

Meter M_1 reads 1.0 A.

What are the readings on M_2 and M_3 ?

	reading on M_2 / A	reading on M_3 / A
A	0.5	0.0
B	0.5	0.5
C	0.5	1.0
D	1.0	1.0

37 The diagram shows a torch containing two cells, a switch and a lamp.

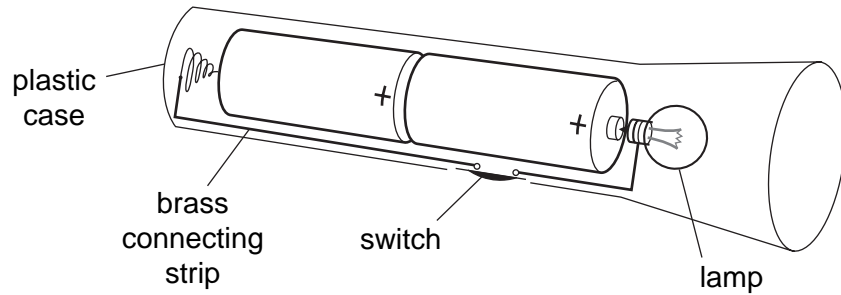

What is the circuit diagram for the torch?

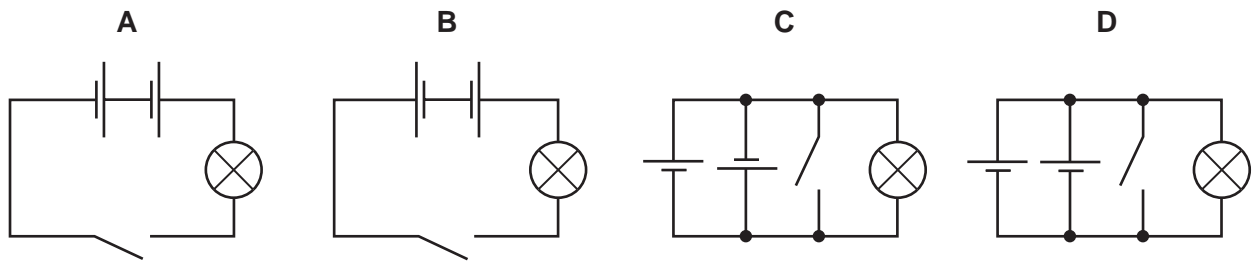

38 On a building site, the metal scaffolding is firmly embedded in the damp ground. A builder holds a mains-operated electric drill in one hand, and with his other hand holds on to the scaffolding.

The power cable of the drill is damaged where it enters the metal casing of the drill.

What danger does this present to the builder?

- A A current could flow through the builder and electrocute him.
- B A current in the scaffolding could heat it up and burn him.
- C The large current could blow the fuse and damage the drill.
- D The large current could make the motor spin too quickly.

- 39 A transformer is to be used to provide a 10V output from a 100V supply.

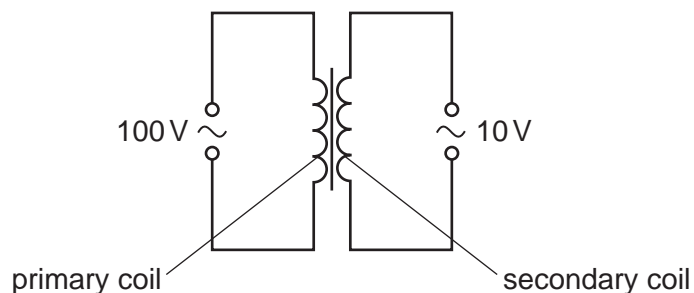

What are suitable numbers of turns for the primary coil and for the secondary coil?

	number of turns on the primary coil	number of turns on the secondary coil
A	100	1000
B	200	110
C	400	490
D	800	80

- 40 The diagram shows the paths of three different types of radiation, X, Y and Z.

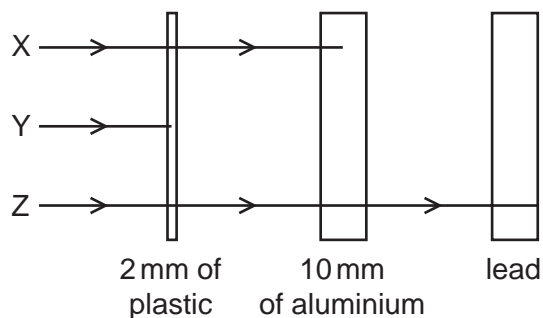

Which row in the table correctly identifies X, Y and Z?

	X	Y	Z
A	alpha radiation	beta radiation	gamma radiation
B	beta radiation	alpha radiation	gamma radiation
C	beta radiation	gamma radiation	alpha radiation
D	gamma radiation	alpha radiation	beta radiation

BLANK PAGE

DATA SHEET
The Periodic Table of the Elements

		Group																																																																	
I	II	III	IV	V	VI	VII	O																																																												
7 Li Lithium 3	9 Be Beryllium 4	1 H Hydrogen 1	11 B Boron 5	12 C Carbon 6	14 N Nitrogen 7	16 O Oxygen 8	19 F Fluorine 9	20 Ne Neon 10	23 Na Sodium 11	24 Mg Magnesium 12	27 Al Aluminium 13	28 Si Silicon 14	31 P Phosphorus 15	32 S Sulfur 16	35.5 Cl Chlorine 17	40 Ar Argon 18	39 K Potassium 19	40 Ca Calcium 20	45 Sc Scandium 21	48 Ti Titanium 22	51 V Vanadium 23	52 Cr Chromium 24	55 Mn Manganese 25	56 Fe Iron 26	59 Co Cobalt 27	59 Ni Nickel 28	64 Cu Copper 29	65 Zn Zinc 30	70 Ga Gallium 31	73 Ge Germanium 32	75 As Arsenic 33	79 Se Selenium 34	80 Br Bromine 35	84 Kr Krypton 36	85 Rb Rubidium 37	88 Sr Strontium 38	89 Y Yttrium 39	91 Zr Zirconium 40	93 Nb Niobium 41	96 Mo Molybdenum 42	101 Ru Ruthenium 44	106 Pd Palladium 46	112 Cd Cadmium 48	115 In Indium 49	119 Sn Tin 50	122 Sb Antimony 51	127 I Iodine 53	131 Xe Xenon 54	133 Cs Caesium 55	137 Ba Barium 56	139 La Lanthanum 57	178 Hf Hafnium 72	181 Ta Tantalum 73	184 W Tungsten 74	190 Os Osmium 76	192 Ir Iridium 77	195 Pt Platinum 78	197 Au Gold 79	201 Hg Mercury 80	204 Tl Thallium 81	207 Pb Lead 82	209 Bi Bismuth 83	210 Po Polonium 84	210 At Astatine 85	210 Rn Radon 86	226 Ra Radium 88	227 Ac Actinium 89
												140 Ce Cerium 58	141 Pr Praseodymium 59	144 Nd Neodymium 60	150 Sm Samarium 62	152 Eu Europium 63	157 Gd Gadolinium 64	159 Tb Terbium 65	162 Dy Dysprosium 66	165 Ho Holmium 67	167 Er Erbium 68	169 Tm Thulium 69	173 Yb Ytterbium 70	175 Lu Lutetium 71	232 Th Thorium 90	238 U Uranium 92	238 Pa Protactinium 91	238 Np Neptunium 93	238 Pu Plutonium 94	238 Am Americium 95	238 Cm Curium 96	238 Bk Berkelium 97	238 Cf Californium 98	238 Es Einsteinium 99	238 Fm Fermium 100	238 Md Mendelevium 101	238 No Nobelium 102	238 Lr Lawrencium 103																													

*58-71 Lanthanoid series
†90-103 Actinoid series

a	X
Key	b

a = relative atomic mass
X = atomic symbol
b = proton (atomic) number

The volume of one mole of any gas is 24 dm³ at room temperature and pressure (r.t.p.).

Permission to reproduce items where third-party owned material protected by copyright is included has been sought and cleared where possible. Every reasonable effort has been made by the publisher (UCLES) to trace copyright holders, but if any items requiring clearance have unwittingly been included, the publisher will be pleased to make amends at the earliest possible opportunity.

University of Cambridge International Examinations is part of the Cambridge Assessment Group. Cambridge Assessment is the brand name of University of Cambridge Local Examinations Syndicate (UCLES), which is itself a department of the University of Cambridge.