



UNIVERSITY OF CAMBRIDGE INTERNATIONAL EXAMINATIONS
International General Certificate of Secondary Education

CANDIDATE
NAME

CENTRE
NUMBER

--	--	--	--	--

CANDIDATE
NUMBER

--	--	--	--

* 1 3 9 6 7 2 4 7 5 0 *

COMBINED SCIENCE

0653/62

Paper 6 Alternative to Practical

October/November 2010

1 hour

Candidates answer on the Question paper

No Additional Materials are required.

READ THESE INSTRUCTIONS FIRST

Write your Centre number, candidate number and name on all the work you hand in.

Write in dark blue or black pen.

You may use a soft pencil for any diagrams, graphs, tables or rough working.

Do not use staples, paper clips, highlighters, glue or correction fluid.

DO NOT WRITE IN ANY BARCODES.

Answer **all** questions.

At the end of the examination, fasten all your work securely together.

The number of marks is given in brackets [] at the end of each question or part question.

For Examiner's Use	
1	
2	
3	
4	
5	
6	
Total	

This document consists of **20** printed pages and **4** blank pages.



1 Some fruit juices contain protease enzymes.

A student did an experiment to compare the ability of different fruit juices to digest protein. She used a solid protein that was weighed before and after immersion in the juice. When the protein was broken down the mass of the protein decreased.

The student had four pieces of protein of approximately equal mass.

- She weighed the first piece and recorded the mass in Table 1.1. She then divided it into small pieces then put these into a test-tube.
- She treated the other three pieces in the same way.
- The student then added a different fruit juice to each tube, keeping the volume of each fruit juice the same.
- She placed the four test-tubes in a warm water bath and left them for 10 minutes.
- After this time she poured the juice out of the first tube, removed the pieces of protein, blotted them dry, then weighed them together. She recorded the new mass in Table 1.1.
- She repeated this procedure with the remaining three tubes.

Table 1.1

test-tube	type of juice added	mass at start/g	mass at end/g	change in mass/g
1	orange	5.8	5.6	
2	lemon	6.8	6.5	
3	pineapple	6.4		
4	mango	5.8		

- (a) The balance windows in Fig. 1.1 show the mass of the protein after immersion in pineapple and mango juices.

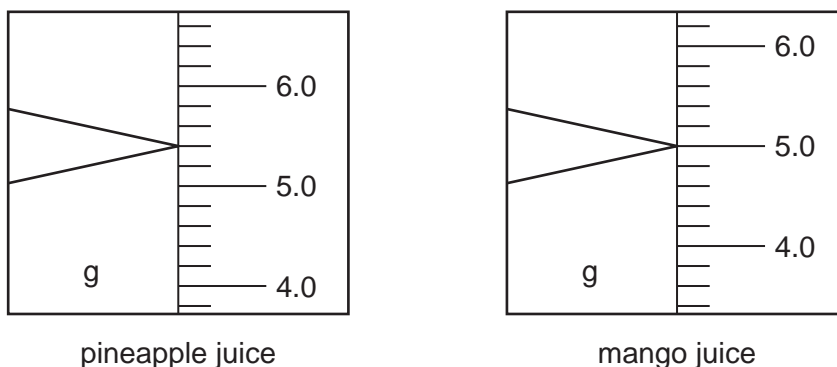

Fig. 1.1

- (i) Read the masses shown by the balance windows in Fig. 1.1 and enter them in Table 1.1. [2]
- (ii) Complete Table 1.1 by calculating the change in mass in each test-tube. [4]

(b) Which fruit juice showed the greatest protease activity?

.....

Explain your answer.

.....

..... [2]

(c) The orange and lemon juices are acidic. Design an experiment to find out if acid rather than protease can cause the protein to lose mass.

.....

.....

.....

.....

.....

.....

.....

..... [2]

- 2 The teacher gives a student samples of two elements, a grey powder and a yellow powder. The student is carrying out some experiments on these two powders. He tests the powders using the apparatus in an electrical circuit shown in Fig. 2.1.

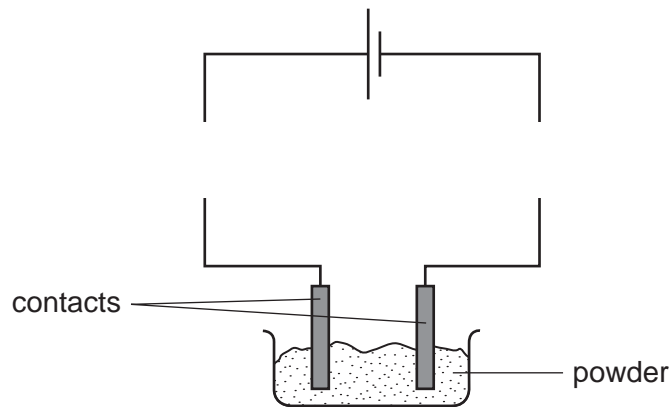

Fig. 2.1

- (a) (i) Complete the circuit diagram by drawing **two** different symbols for components that will show if an electric current is passing through the powder. [2]

- (ii) If a current passes through it, what type of element is in the powder?

..... [1]

- (b) The student thinks that the grey powder is the element iron and the yellow powder is sulfur. He mixes some of the grey powder with the yellow powder. Then he tries to separate them again.

Explain how the iron can be easily separated from the sulfur by a physical process.

.....
 [1]

(c) (i) The student wants to make the mixture of the powders react chemically. Suggest how he can do this. You may draw a labelled diagram to show the apparatus you would use.

.....
..... [2]

(ii) Explain why the method you have shown in part (i) will cause the atoms of the two elements to react together.

.....
..... [1]

(iii) After the reaction has started the mixture becomes red-hot and gives out heat.

What type of reaction has taken place?

..... [1]

(d) A black solid compound is left after the reaction. The student grinds up the solid making a black powder.

Suggest a physical or chemical test to show that the black powder is different from either of the two elements.

test

result of this test on the black powder

[2]

- 3 A student is carrying out experiments using a semi-circular glass block, to find the refractive index.

She places the glass block on a sheet of graph paper, as in Fig. 3.1. She looks through the glass block to see the pattern of the graph paper. Fig. 3.2 shows what she observes.

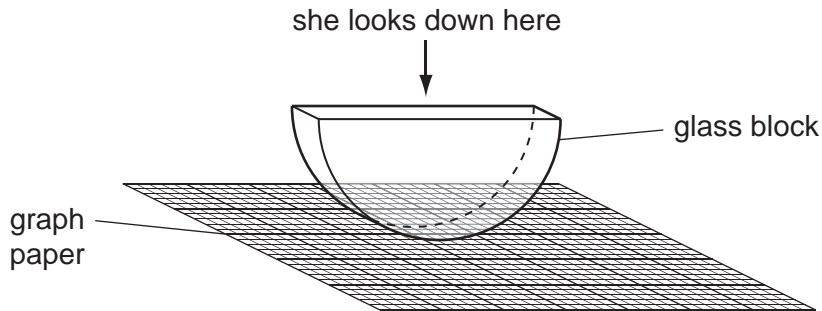

Fig. 3.1

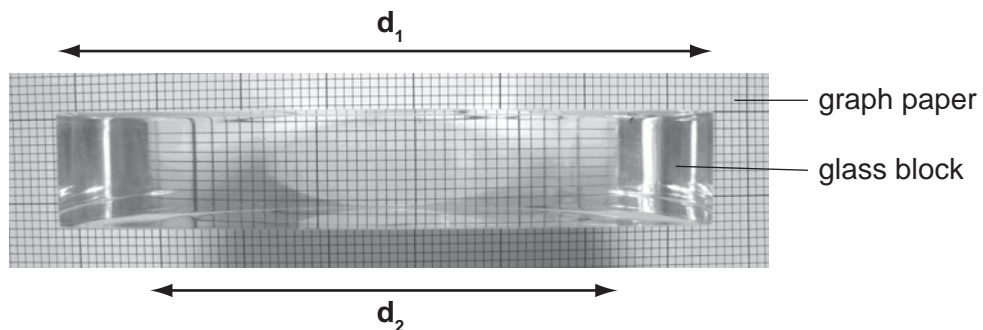

Fig. 3.2

- (a) (i) In Fig. 3.2, measure d_1 , the actual distance across the glass block, in centimetres to the nearest millimetre.

$$d_1 = \dots\dots\dots \text{cm} \quad [1]$$

- (ii) In Fig. 3.2, measure d_2 , the length of the image of the graph paper that the student sees, in centimetres to the nearest millimetre.

$$d_2 = \dots\dots\dots \text{cm} \quad [1]$$

- (iii) Calculate the value of $\frac{d_1}{d_2}$. This is the refractive index of the glass block.

$$\frac{d_1}{d_2} = \dots\dots\dots [1]$$

The student places the glass block on a piece of plain paper. She draws a line around it. She removes the glass block and draws a normal line at point **O**. Then she draws lines every 10 degrees to show incident rays passing through the glass block and emerging at point **O**. This is shown in Fig. 3.3.

For
Examiner's
Use

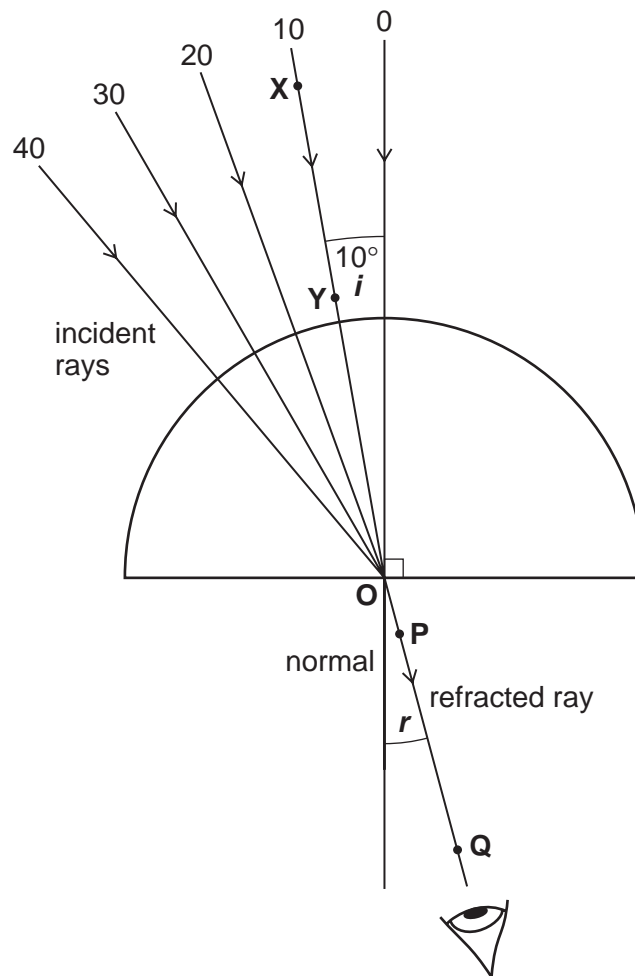

Fig. 3.3

- The student replaces the glass block and then places two pins, **X** and **Y**, on the 10-degree line. This shows the incident ray when the angle of incidence $i_1 = 10$ degrees.
- She views the pins through the opposite side of the block and places two more pins, **P** and **Q**, in line with the image of pins **X** and **Y**.
- She removes the pins and the block and draws the refracted ray passing through pins **P** and **Q**.
- She measures r_1 , the angle of refraction and records it in Table 3.1.
- She repeats the experiment, using the 20-degree, 30-degree and 40-degree lines as the incident rays and finds the angles of refraction r_2 , r_3 and r_4 . She records the results in Table 3.1.

Table 3.1

angle of incidence, i /degrees	sine i	angle of refraction, r /degrees	sine r
$i_0 = 0$	0.00	0	0.00
$i_1 = 10$	0.17	14	0.25
$i_2 = 20$	0.34	31	0.51
$i_3 = 30$	0.50		
$i_4 = 40$	0.64		

For
Examiner's
Use

- (b) Fig. 3.4 shows the diagram that the student drew using the 30-degree and the 40-degree lines as incident rays i_3 and i_4 .

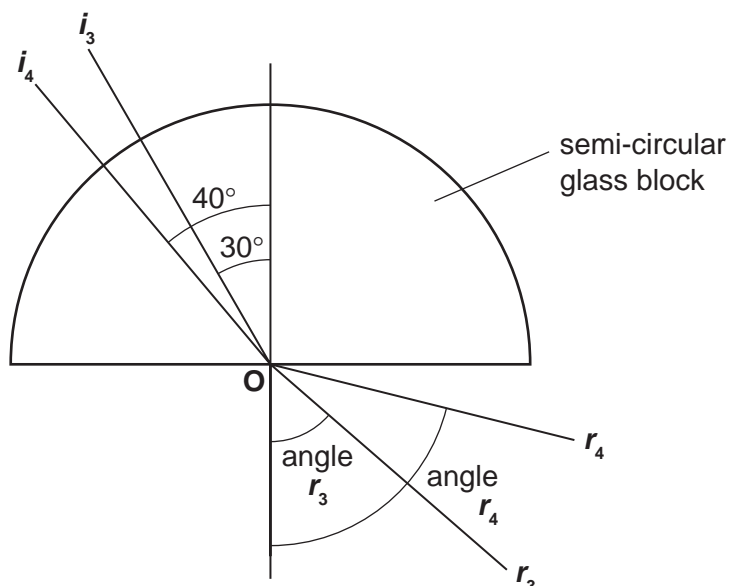

Fig. 3.4

- (i) Measure r_3 , and r_4 , the angles of refraction shown in Fig. 3.4 and record them in Table 3.1. [2]
- (ii) Use Table 3.2 (on page 10) to find the sines of the angles of refraction r_3 and r_4 . Record the results in Table 3.1. [1]

Table 3.2

angle/°	sine	angle/°	sine	angle/°	sine
0	0.00	30	0.50	49	0.75
10	0.17	31	0.52	50	0.77
11	0.19	32	0.53	51	0.78
12	0.21	33	0.54	52	0.79
13	0.22	34	0.56		
14	0.24	35	0.57	70	0.94
15	0.26	36	0.59	71	0.95
16	0.28	40	0.64	72	0.95
17	0.29	45	0.71	73	0.96
18	0.31	46	0.72	74	0.96
19	0.33	47	0.73	75	0.97
20	0.34	48	0.74	76	0.97

For
Examiner's
Use

- (iii) On Fig 3.5, the student is plotting the values of sine r against the values of sine i , from Table 3.1. Add the **two** missing points to the graph and draw the best straight line. [1]

For
Examiner's
Use

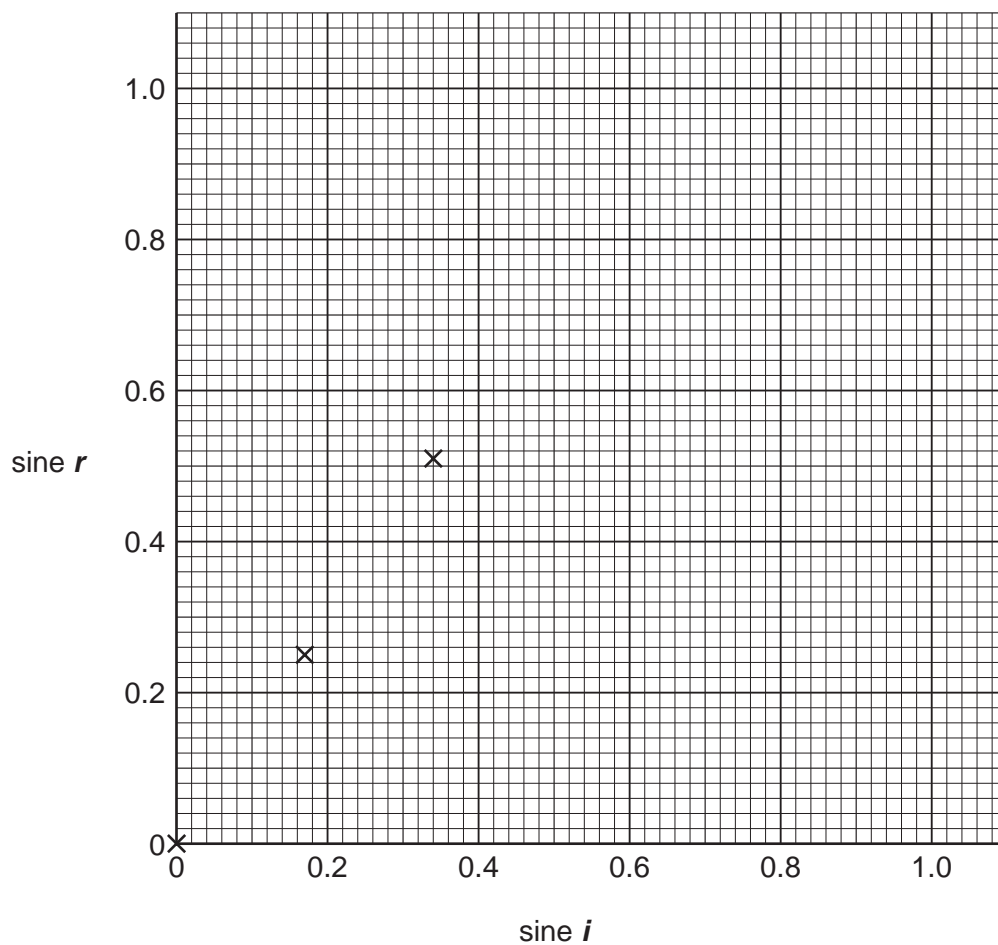

Fig. 3.5

- (iv) Calculate the gradient of the straight line you have drawn. This is equal to the refractive index of the glass block. Show on the graph the distances that you use in the calculation.

gradient of the line = [2]

- (c) The value of $\frac{d_1}{d_2}$ calculated in part (a)(iii) is also equal to the refractive index of the glass block. Suggest which value, (a)(iii) or (b)(iv) is more accurate and give a reason for your choice.

Value is more accurate because

.....

.....

..... [1]

For
Examiner's
Use

- 4 (a) Transpiration in leaves can be studied using the simple potometer shown in Fig. 4.1. As water vapour is evaporated from the leaves it is replaced by the stem taking water from the tube. The rate of transpiration can be determined by measuring the distance travelled by the bubble up the tube in a fixed time.

For
Examiner's
Use

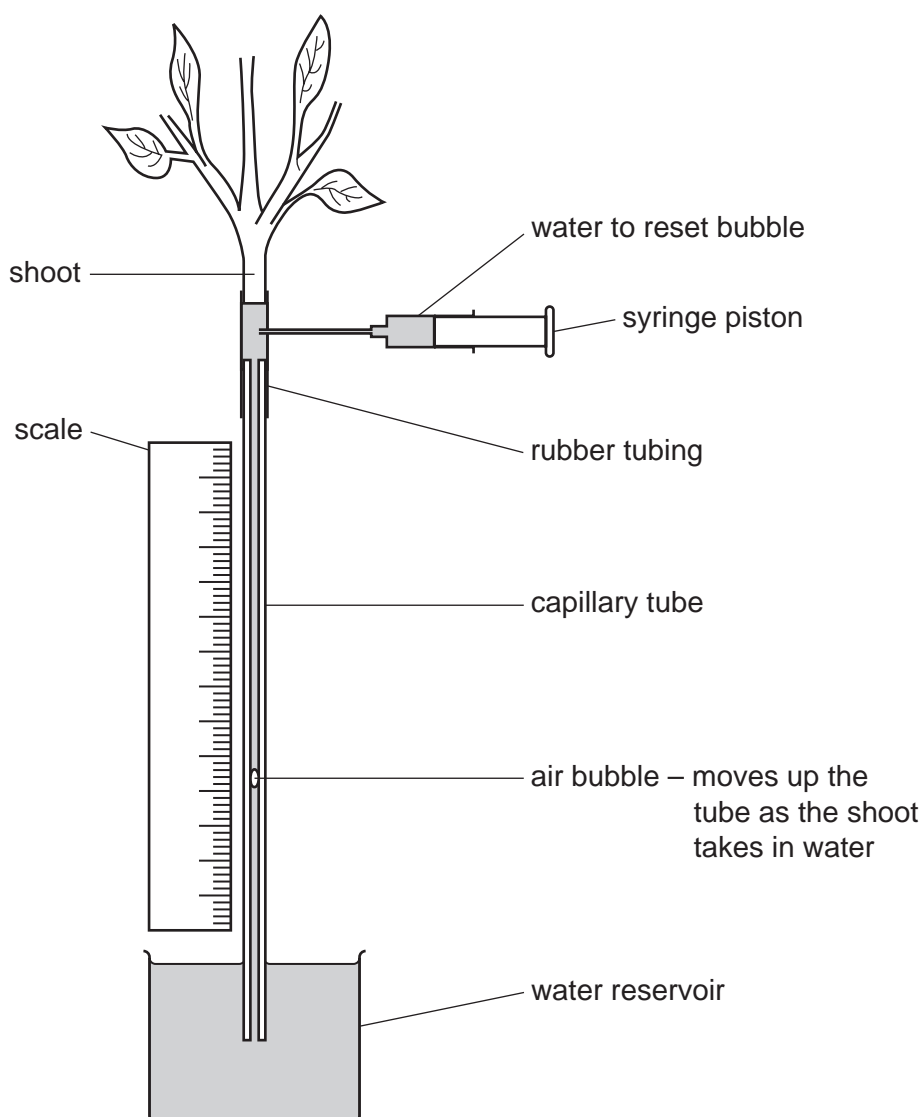

Fig. 4.1

- A student compared the rate of transpiration in still air with windy conditions.
- He set up the apparatus in still air and read the position of the bubble at the beginning and again after four minutes.
- He then repeated this procedure in windy conditions.
- He recorded the readings in Table 4.1.

Table 4.1

conditions of air	position of bubble / cm		distance moved by bubble / cm
	initial	final	
still	0.4		
windy	0.3		

For
Examiner's
Use

- (i) Fig. 4.2 shows the scale with the final readings for the two experiments. Read the scale at the top of the air bubble and enter the readings in Table 4.1. [2]

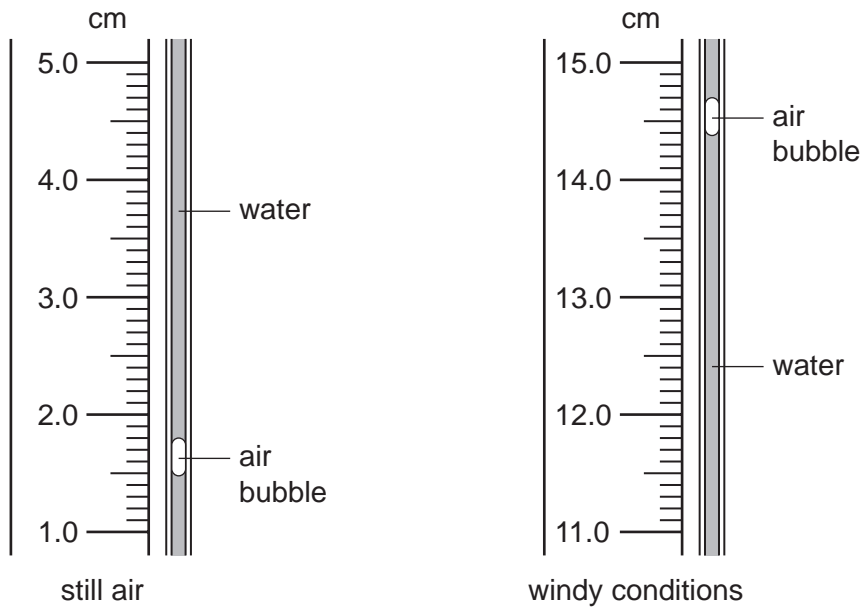

Fig. 4.2

- (ii) Complete Table 4.1 by calculating the distance moved by the air bubble in the two experiments. [2]
- (iii) Using these distances and the time of four minutes calculate the rate of water vapour loss in each case. Show your working.

still air

rate = cm/minute

windy conditions

rate = cm/minute [2]

(b) Explain the difference between the two rates of transpiration.

.....
.....
.....
..... [2]

(c) Explain why the following precautions should be taken when setting up the experiment.

(i) The stem should be cut under water and immediately transferred to the apparatus.

.....
.....

(ii) Care should be taken not to allow water to wet the leaves during the cutting of the stem.

.....
..... [2]

- 5 The teacher has given the students four bottles labelled **A**, **B**, **C** and **D**. The bottles contain hydrochloric acid, nitric acid, sodium chloride solution and potassium nitrate solution. The students carry out chemical tests to identify the solutions.

For
Examiner's
Use

Test 1

To 1 cm depth of each of the solutions **A**, **B**, **C** and **D** in separate test-tubes, the students add a spatula full of solid sodium carbonate. They record their observations and conclusions in Table 5.1.

Table 5.1

sodium carbonate added to solution	observations	possible names of the solution
A	hydrochloric acid or nitric acid
B	sodium chloride or potassium nitrate
C	sodium chloride or potassium nitrate
D	hydrochloric acid or nitric acid

- (a) In column 2 of Table 5.1, suggest the observations that lead to the possible names in column 3. [2]

Test 2

For
Examiner's
Use

To 1 cm depth of each of the solutions **A**, **B**, **C** and **D** in separate test-tubes, the students add an equal volume of silver nitrate solution.

They record their observations and conclusions in Table 5.2. They base their conclusions **only** on the results of this test.

Table 5.2

silver nitrate added to solution	observations	possible names of the solution
A	no change or
B	white precipitate or
C	no change or
D	white precipitate or

- (b) In Table 5.2, complete column 3 by deciding the possible names of each of the solutions **A**, **B**, **C** and **D**.

You must base your conclusions **only** on the results of test 2, **not** test 1. [2]

- (c) Consider the results of test 1 and test 2 together, and decide the correct names of the solutions.

correct name of solution **A**

correct name of solution **B**

correct name of solution **C**

correct name of solution **D** [3]

(d) Describe a test that you could carry out to confirm the identity of the solution that you think is potassium nitrate.

*For
Examiner's
Use*

Give all necessary details and the results of the test.

.....
.....
.....
..... [3]

- 6 The teacher is making an electromagnet. He is using it to find out how the force of attraction varies with the current passed. The apparatus is shown in Fig. 6.1.

For
Examiner's
Use

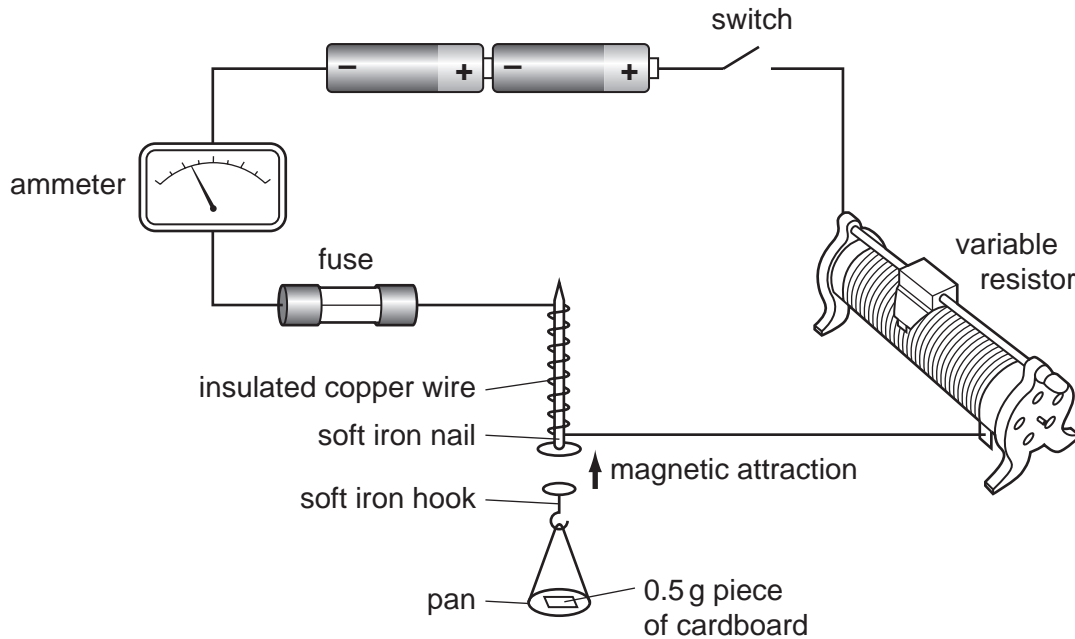

Fig. 6.1

- The teacher winds a long length of insulated copper wire round a soft iron nail, to make an electromagnet.
- He fixes the electromagnet vertically and connects it in the circuit shown in Fig. 6.1.
- He makes a small soft iron nail into a hook and fixes a plastic pan on to the hook.
- He makes 0.5 g weights by cutting pieces of cardboard.
- He uses the weights to test the electromagnet.

The teacher has a piece of cardboard that is 5 cm x 10 cm and has a mass of 5 g. He cuts the cardboard into equal sized pieces each weighing 0.5 g.

- (a) Suggest the length and width of one of these 0.5 g pieces of card.

length

width

[1]

Procedure

- The teacher closes the switch shown in Fig. 6.1. He uses the variable resistor to set the current at 1.0 amps.
- He places a 0.5 g mass into the pan and allows the electromagnet to attract the hook.
- He slowly decreases the current in the circuit until the hook falls off the electromagnet.
- He notes the current and records it in Table 6.1.
- He repeats the experiment using two 0.5 g pieces of card.
- He keeps increasing the mass on the hook until he has four sets of data.

Table 6.1

For
Examiner's
Use

mass of card in the pan/g	current flowing when the pan falls/A
0.5	0.40
1.0	0.55
1.5	
2.0	

- (b) Fig 6.2 shows the ammeter readings for masses of 1.5 g and 2.0 g of the card. Read the ammeters and record the currents in Table 6.1. [2]

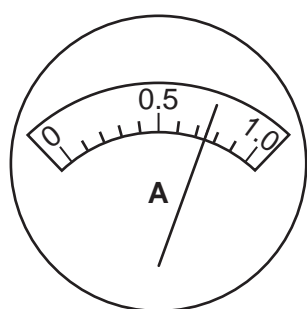

mass of card = 1.5 g

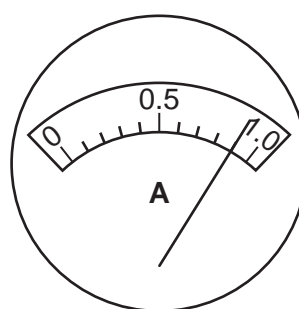

mass of card = 2.0 g

Fig. 6.2

- (c) During the experiment, the teacher sets the current at 1.0 A and then gradually decreases the current until the hook falls off the electromagnet.

To decrease the current, does he **increase** or **decrease** the resistance of the variable resistor?

Explain your answer.

.....

.....

..... [1]

- (d) On the graph grid below, plot the current against the mass of card in pan. Draw the best straight line, which should not pass through the origin. [2]

For
Examiner's
Use

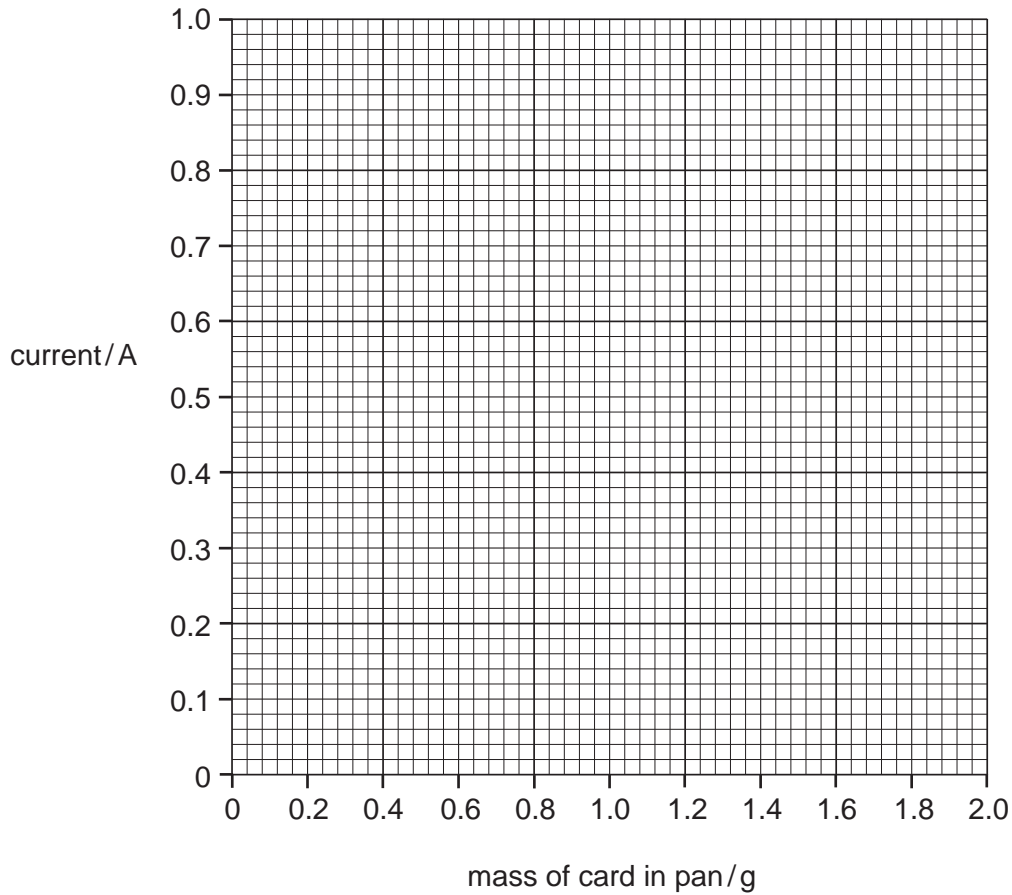

- (e) Explain why the straight line of the graph does not pass through the point (0,0).

.....
 [1]

- (f) Both soft iron and steel are magnetic materials.

Explain why the electromagnet and the hook are made from soft iron and not from steel.

.....

 [2]

- (g) Explain why the copper wire used to make the electromagnet must be insulated.

.....
 [1]

BLANK PAGE

Permission to reproduce items where third-party owned material protected by copyright is included has been sought and cleared where possible. Every reasonable effort has been made by the publisher (UCLES) to trace copyright holders, but if any items requiring clearance have unwittingly been included, the publisher will be pleased to make amends at the earliest possible opportunity.

University of Cambridge International Examinations is part of the Cambridge Assessment Group. Cambridge Assessment is the brand name of University of Cambridge Local Examinations Syndicate (UCLES), which is itself a department of the University of Cambridge.