

UNIVERSITY OF CAMBRIDGE INTERNATIONAL EXAMINATIONS  
International General Certificate of Secondary Education

**CO-ORDINATED SCIENCES**

**0654/05**

Paper 5 Practical Test

May/June 2006

**CONFIDENTIAL INSTRUCTIONS**

**Great care should be taken to ensure that any confidential information given does not reach the candidates either directly or indirectly.**

**The Supervisor's attention is drawn to the form on page 8 which must be completed and returned with the scripts.**

If you have any queries regarding these Instructions, please contact CIE  
by e-mail: [International@cie.org.uk](mailto:International@cie.org.uk),  
by phone: +44 1223 553554,  
by fax: +44 1223 553558,  
stating the nature of the query and the syllabus number quoted above.

This document consists of **5** printed pages and **3** blank pages.



### Instructions for preparing apparatus

These instructions detail the apparatus, reagents and specimens required by each candidate for each experiment in this paper. A summary of the questions that will be presented to the candidates is included, where appropriate, to allow the teacher to test the apparatus appropriately. **No access is permitted to the question paper in advance of the examination session.**

It is assumed that the ordinary apparatus of a science laboratory will be available, including a supply of purified water (distilled or deionised).

It is expected that candidates will have either a watch or sight of a clock with second hand.

If arrangements are made for different sessions for different groups of candidates, care must be taken to ensure that the different groups of candidates are effectively isolated so that **no information passes between them.**

### For Question 1

*Each candidate will require:*

- (i) 8 test-tubes, size 125 x15 mm;
- (ii) 6 small labels for the test-tubes;
- (iii) a test-tube rack;
- (iv) 5 syringes of volume 5 cm<sup>3</sup>;
- (v) 1 syringe of volume 1 cm<sup>3</sup>;

If there is a limited supply of syringes, one 5 cm<sup>3</sup> and one 1 cm<sup>3</sup> syringe could be given to each candidate with instructions and the means to wash out the syringes. Similarly if no syringes are available, 10 cm<sup>3</sup> measuring cylinders could be used instead.

- (vi) 10 cm<sup>3</sup> of 2% amylase solution;
- (vii) 10 cm<sup>3</sup> of 1% starch solution;
- (viii) approximately 20 cm<sup>3</sup> of deionised (distilled) water;
- (ix) 10 cm<sup>3</sup> of 1% pepsin solution;
- (x) 10 cm<sup>3</sup> of protein solution. This should be made as follows: Boil the white of an egg in 1 dm<sup>3</sup> of deionised water. Filter the solution through a coarse cloth, e.g. muslin to remove the large particles. The resulting filtrate should be cloudy.

The volumes of the solutions are generous in quantity for the practical. However, extra should be available if the candidates request it.

- (xi) hydrochloric acid of concentration approximately 1 mol dm<sup>-3</sup>;
- (xii) access to iodine solution;
- (xiii) access to a water bath set at approximately 40 °C. There should be a means of support for 6 test-tubes;

The tubes are to be kept at approximately 40 °C for 5 minutes. It is acceptable to use alternatives to a water bath and for the temperature of the water to fall slightly during the 5 minute period. A controlled temperature of approximately 40 °C is required later in the question and the warm water may need replacing if a water bath is not used.

- (xiv) a white tile.
- (xv) a glass rod;
- (xvi) a paper towel;
- (xvii) a stopwatch or clock clearly visible;
- (xviii) a small filter funnel;
- (xix) a piece of coarse material e.g. gauze or muslin, suitable for lining the filter funnel;
- (xx) a Bunsen burner;
- (xxi) a test-tube holder.

**Note**

The amylase solution should be capable of breaking down the starch solution in 5 minutes at 40 °C when mixed in 2:2:1 ratio of starch, amylase and water.

The pepsin solution must be capable of breaking down the protein solution in 5 minutes at 40 °C when mixed in a ratio of 2:2:1 of pepsin, protein solution and acid.

**For Question 2**

*Each candidate will require:*

- (i) about 30 g of plasticine (modelling clay);
- (ii) a ruler calibrated in mm;
- (iii) access to a balance reading to the nearest gram;
- (iv) 100 cm<sup>3</sup> measuring cylinder;
- (v) metre rule
- (vi) a knife edge for balancing the metre rule or other suitable pivot;
- (vii) a retort stand and clamp for holding the pivot or suitable alternative;
- (viii) a 25 g mass;
- (ix) thread to attach plasticine and 25 g mass to the rule;
- (x) paper towel or tissue to dry the plasticine.

**For Question 3**

Each candidate will require:

- (i) a bung to fit a 125 x 15 mm hard glass test-tube. The test-tube should contain a short length of glass tubing which is connected to a piece of rubber tubing to act as a delivery tube. See Fig. 3.1;

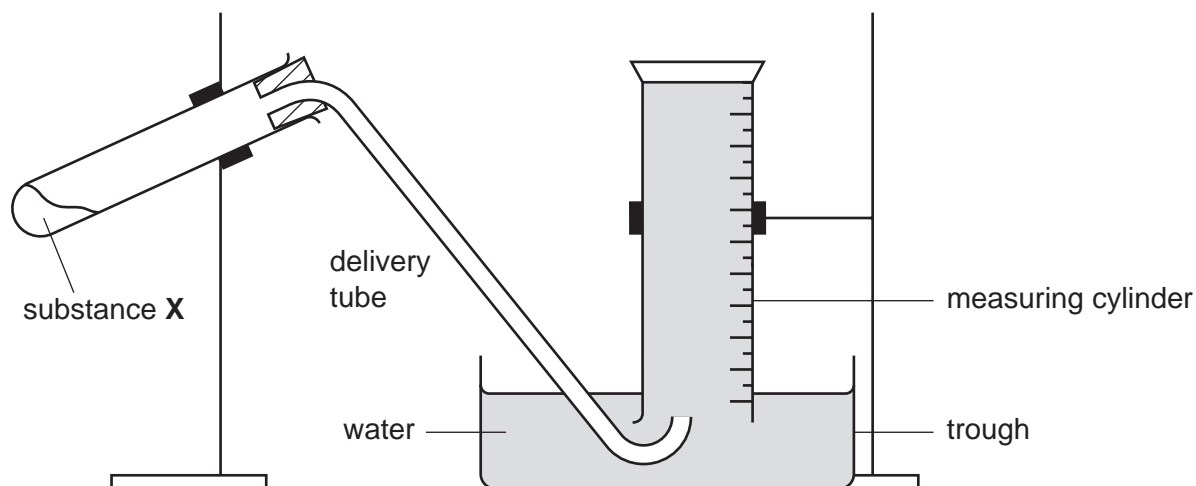

**Fig. 3.1**

- (ii) two stands and clamps;  
 (iii) a 100 cm<sup>3</sup> measuring cylinder;  
 (iv) a water trough;  
 (v) four test-tubes 125 x 15 mm;  
 (vi) between 0.30 g and 0.40 g accurately weighed of sodium hydrogencarbonate in a 125 x 15 mm hard glass test-tube. This should preferably be taken from a fresh sample. The mass should be clearly labelled and given to the candidate. It should also indicate that this sample is to be used for part (a);  
 (vii) a second sample of about 0.2 g of sodium hydrogencarbonate in a suitable container labelled substance X;  
 (viii) access to limewater, dilute hydrochloric acid, Universal Indicator solution and a colour chart.

Spare materials and equipment should be available and can be provided without penalty. **Candidates should be made aware of this.**

*Information required from the Supervisor:*

**The Supervisor is asked to carry out the experiments and to enter the results on a spare copy of the examination paper, clearly marked 'Supervisor's Results' and showing the Centre number. This should be returned with the scripts. Failure to do so may cause the candidates to be penalised.**





**BLANK PAGE**

**This form must be completed and returned in the envelope with the scripts together with the seating plan and the Supervisor's Results mentioned on page 4.**

**May/June 2006**

*General*

The Supervisor is invited to give details of any difficulties experienced by particular candidates giving their names and candidate numbers. These should include reference to:

- (a) difficulties due to faulty apparatus;
- (b) accidents to apparatus or materials;
- (c) physical handicaps, e.g. short sight, colour blindness;
- (d) any other information that is likely to assist the Examiner, especially if this cannot be discovered in the scripts;
- (e) any help given to a candidate.

*The Supervisor is asked to supply the following information:*

Plan of work benches, giving details by candidate numbers of the places occupied by the candidates for each session and a copy of the 'Supervisor's Results'.

NAME OF CENTRE .....

SIGNED .....  
*Supervisor*

CENTRE NUMBER .....

DECLARATION (to be signed by the Principal)

The preparation of this practical examination has been carried out so as to maintain fully the security of the examination.

NAME .....  
(in block capitals)

SIGNED ..... (Principal)



Permission to reproduce items where third-party owned material protected by copyright is included has been sought and cleared where possible. Every reasonable effort has been made by the publisher (UCLES) to trace copyright holders, but if any items requiring clearance have unwittingly been included, the publisher will be pleased to make amends at the earliest possible opportunity.

University of Cambridge International Examinations is part of the University of Cambridge Local Examinations Syndicate (UCLES), which is itself a department of the University of Cambridge.