



UNIVERSITY OF CAMBRIDGE INTERNATIONAL EXAMINATIONS  
International General Certificate of Secondary Education

www.XtremePapers.com

**CO-ORDINATED SCIENCES**

**0654/05**

Paper 5 Practical Test

**May/June 2007**

CONFIDENTIAL INSTRUCTIONS

**Great care should be taken to ensure that any confidential information given does not reach the candidates either directly or indirectly.**

**The Supervisor's attention is drawn to the form on page 8 which must be completed and returned with the scripts.**

If you have any queries regarding these instructions, please contact CIE

by e-mail: [International@cie.org.uk](mailto:International@cie.org.uk)

by phone: +44 1223 553554

by fax: +44 1223 553558

stating the nature of the query and the syllabus number quoted above.

This document consists of **5** printed pages and **3** blank pages.



### Instructions for preparing apparatus

These instructions detail the apparatus, reagents and specimens required by each candidate for each experiment in this paper. A summary of the questions that will be presented to the candidates is included, where appropriate, to allow the teacher to test the apparatus appropriately. **No access is permitted to the question paper in advance of the examination session.**

It is assumed that the ordinary apparatus of a science laboratory will be available, including a supply of purified water (distilled or deionised).

If arrangements are made for different sessions for different groups of candidates, care must be taken to ensure that the different groups of candidates are effectively isolated so that **no information passes between them.**

### For Question 1

*Each candidate will require:*

- (i) a dicotyledonous leaf, at least 5 cm in length. The leaf should have the veins clearly visible on the lower surface, the lower surface should be a paler green than the upper surface, and bubbles of air should clearly be seen appearing from the lower surface when it is immersed in very hot water; The leaf should be labelled **A** using a label attached to the petiole.
- (ii) a pair of tweezers;
- (iii) access to a very hot water bath, just below boiling point. Several candidates may share the same water bath if this can be done without overcrowding. Alternatively, candidates may be supplied with a 250 cm<sup>3</sup> beaker, or any larger size, containing the very hot water.
- (iv) four leaves, labelled with their names. The leaves should be clearly different in structure. Examples of suitable leaves are shown.

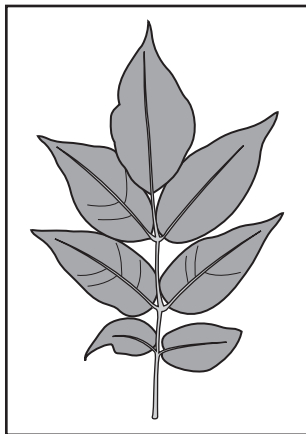

ash

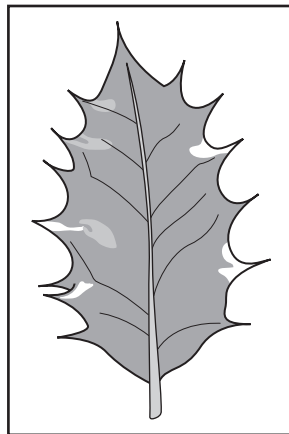

holly

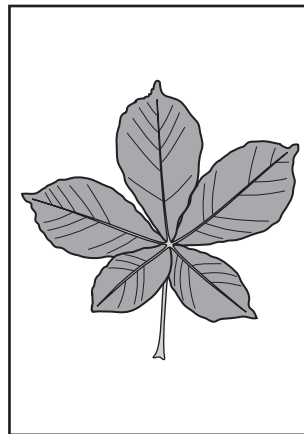

horse-chestnut

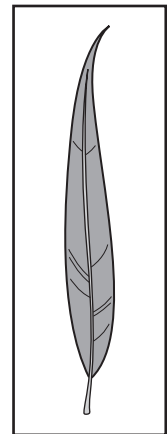

willow

**For Question 2**

Each candidate will require:

- (i) a power source of approximately 1.5 V – 2.0 V;
- (ii) 2 similar lamps of the same rating in suitable holders: any low voltage lamps will be suitable, provided they glow when connected in series with the power supply. Label these 'lamp 1' and 'lamp 2';
- (iii) switch;
- (iv) an ammeter with full scale deflection 0.5 A or 1.0 A;
- (v) a voltmeter with full scale deflection 1.5 V or 3.0 V;
- (vi) sufficient connecting leads to construct the circuit shown in Fig. 2.3

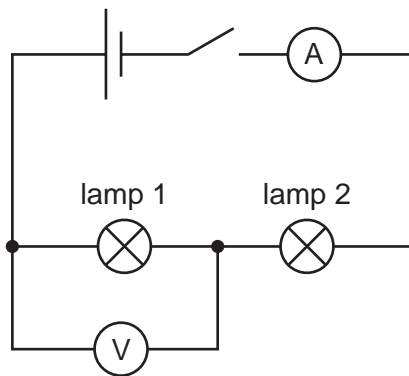

**Fig. 2.3**

Note: The candidates will be required to connect the circuit unassisted and will be credited for doing so. If help is required, it may be given but the candidate number must be noted on the Supervisor's report.

If more than one sitting is necessary, ensure that the circuit is completely disconnected before allowing candidates to begin.

**For Question 3**

*Each Candidate will require:*

- (i) 4 test-tubes size 125 x 15 mm and 2 size 150 x 25 mm;
- (ii) about 1g of copper(II) oxide, labelled **X**;
- (iii) about 1g of manganese(IV) oxide, labelled **Y**;
- (iv) a wooden splint;
- (v) blue litmus paper;
- (vi) a filter funnel;
- (vii) filter paper;
- (viii) about 10 cm<sup>3</sup> hydrogen peroxide (clearly labelled), approximately 5–volume. It is important that this solution reacts with solid **Y** and should be tested on the day of the examination;
- (ix) about 10 cm<sup>3</sup> of hydrochloric acid, concentration about 2 mol dm<sup>-3</sup> labelled **Z**;
- (x) access to aqueous sodium hydroxide and ammonia solution, concentration about 1 mol dm<sup>-3</sup>;
- (xi) a Bunsen burner.

Spare materials and equipment should be available and can be provided without penalty. **Candidates should be made aware of this.**

*Information required from the Supervisor:*

**The Supervisor is asked to carry out the experiments and to enter the results on a spare copy of the examination paper, clearly marked 'Supervisor's Results' and showing the Centre number. This should be returned with the scripts. Failure to do so may cause the candidates to be penalised.**



**BLANK PAGE**

**BLANK PAGE**

**This form must be completed and returned in the envelope with the scripts together with the seating plan and the Supervisor's Results mentioned on page 4.**

**May/June 2007**

*General*

The Supervisor is invited to give details of any difficulties experienced by particular candidates giving their names and candidate numbers. These should include reference to:

- (a) difficulties due to faulty apparatus;
- (b) accidents to apparatus or materials;
- (c) physical handicaps, e.g. short sight, colour blindness;
- (d) any other information that is likely to assist the Examiner, especially if this cannot be discovered in the scripts;
- (e) any help given to a candidate.

*The Supervisor is asked to supply the following information:*

Plan of work benches, giving details by candidate numbers of the places occupied by the candidates for each session and a copy of the 'Supervisor's Results'.

NAME OF CENTRE .....

SIGNED .....  
*Supervisor*

CENTRE NUMBER .....

DECLARATION (to be signed by the Principal)

The preparation of this practical examination has been carried out so as to maintain fully the security of the examination.

NAME .....  
(in block capitals)

SIGNED ..... (Principal)



Permission to reproduce items where third-party owned material protected by copyright is included has been sought and cleared where possible. Every reasonable effort has been made by the publisher (UCLES) to trace copyright holders, but if any items requiring clearance have unwittingly been included, the publisher will be pleased to make amends at the earliest possible opportunity.

University of Cambridge International Examinations is part of the Cambridge Assessment Group. Cambridge Assessment is the brand name of University of Cambridge Local Examinations Syndicate (UCLES), which is itself a department of the University of Cambridge.