



UNIVERSITY OF CAMBRIDGE INTERNATIONAL EXAMINATIONS
International General Certificate of Secondary Education

CANDIDATE
NAME

CENTRE
NUMBER

--	--	--	--	--

CANDIDATE
NUMBER

--	--	--	--

* 9 9 0 2 1 3 5 5 3 8 *

**COMBINED SCIENCE
CO-ORDINATED SCIENCES**

**0653/06
0654/06**

Paper 6 Alternative to Practical

May/June 2007

1 hour

Candidates answer on the Question Paper.

No Additional Materials are required.

READ THESE INSTRUCTIONS FIRST

Write your Centre number, candidate number and name on all the work you hand in.

Write in dark blue or black pen.

You may use a soft pencil for any diagrams, graphs, tables or rough working.

Do not use staples, paper clips, highlighters, glue or correction fluid.

DO NOT WRITE IN ANY BARCODES.

Answer **all** questions.

At the end of the examination, fasten all your work securely together.

The number of marks is given in brackets [] at the end of each question or part question.

For Examiner's Use	
1	
2	
3	
4	
5	
6	
Total	

This document consists of **16** printed pages and **4** blank pages.



BLANK PAGE

- 1 (a) A student placed a leaf on the bench with the lower surface facing upwards. The leaf is shown in Fig. 1.1.



Fig. 1.1.

- (i) Draw the leaf in the space below. Using the letter **T**, label on your diagram a structure involved in the transport of substances through the leaf.

[2]

- (ii) The student compared the upper and lower surfaces of the leaf and observed that the lower surface was lighter in colour than the upper surface.

Suggest an explanation for this.

.....
..... [1]

- (b) The student then immersed the leaf in hot water. She observed bubbles coming only from the **lower** surface.
Explain the observation.

.....
.....
..... [2]

- (c) The following is an example of a key to identify different arthropods. You will be required to construct a key for identifying leaves.

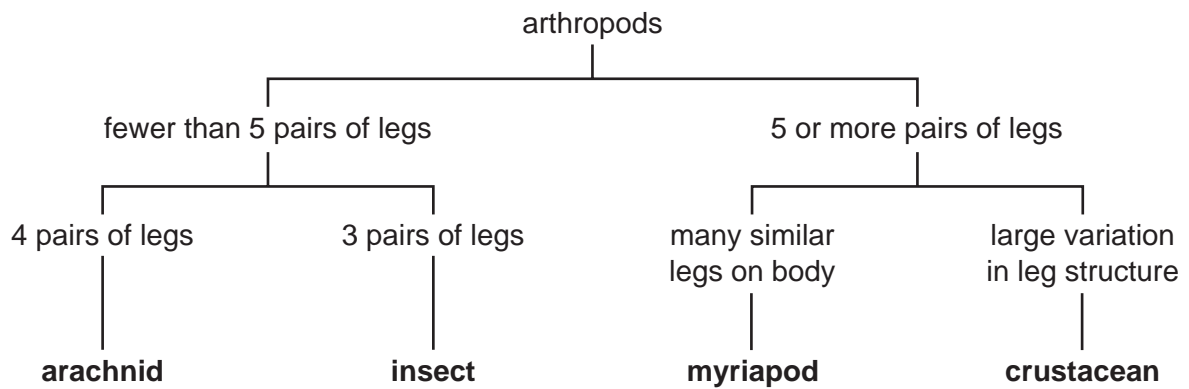

Fig. 1.2 shows four different leaves.

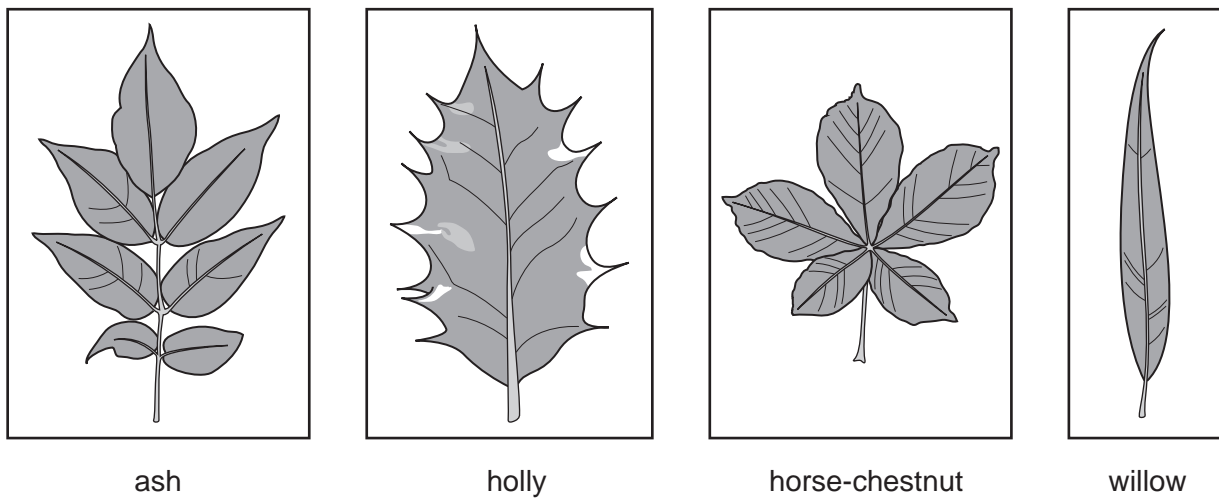

Fig. 1.2

Using visible features construct a key for the leaves. Use the example of a key given opposite to help you. Check that the key would enable all of the leaves to be identified correctly.

[6]

- 2 A student uses a ray box to direct a beam of light towards a plane mirror. The beam of light is reflected. A line at right angles to the mirror (the normal) is drawn on a piece of paper placed underneath. A metre rule is placed on the paper parallel to the mirror. The normal meets the metre rule at the 50 cm mark. This is shown in Fig. 2.1.

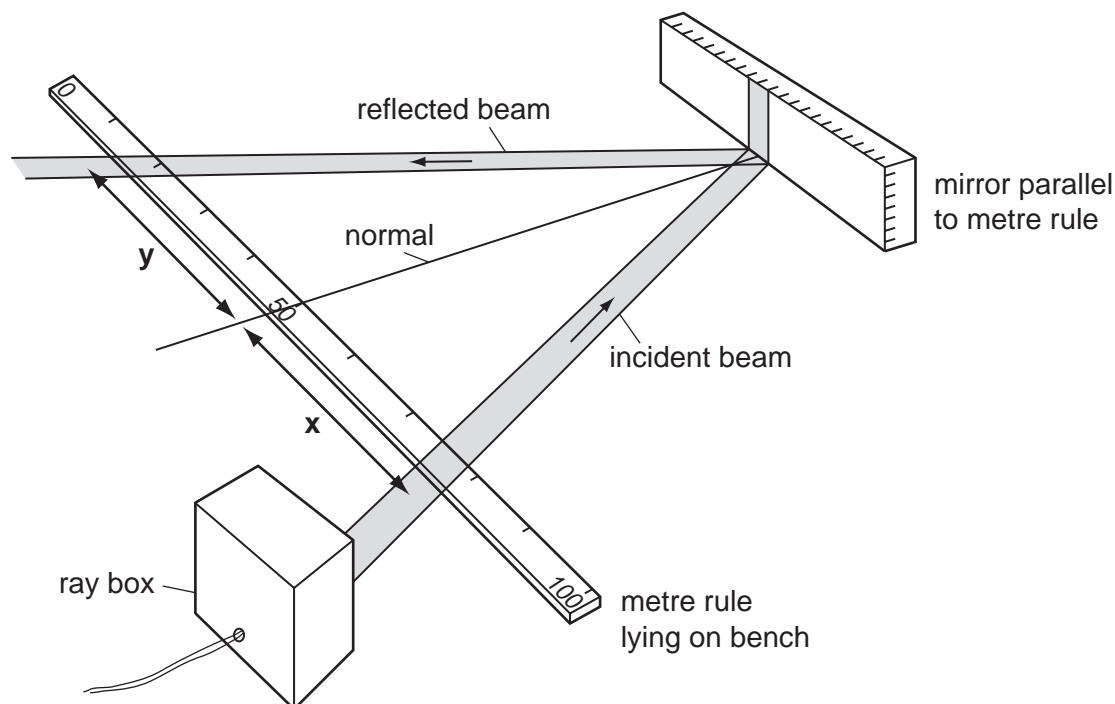

Fig. 2.1

Experiment 1.

The student notes the places where the mid-points of the incident and reflected beams cross the metre rule and records them in Fig. 2.2. He calculates and records the distances x and y .

Experiments 2 and 3.

The student moves the ray box so that each time the beam crosses the metre rule at a different place but meets the mirror at the same point as before.

experiment number	mid-point of incident beam crosses at /cm	distance x /cm	mid-point of reflected beam crosses at /cm	distance y /cm
1	76.5	26.5	24.0	26.0
2				
3				

Fig. 2.2

(a) The incident and reflected beams crossing the metre rule for experiments 2 and 3 are shown in Fig. 2.3.

(i) Read the scales and record the results in Fig. 2.2. [2]

(ii) Calculate the distances x and y for experiments 2 and 3. [2]

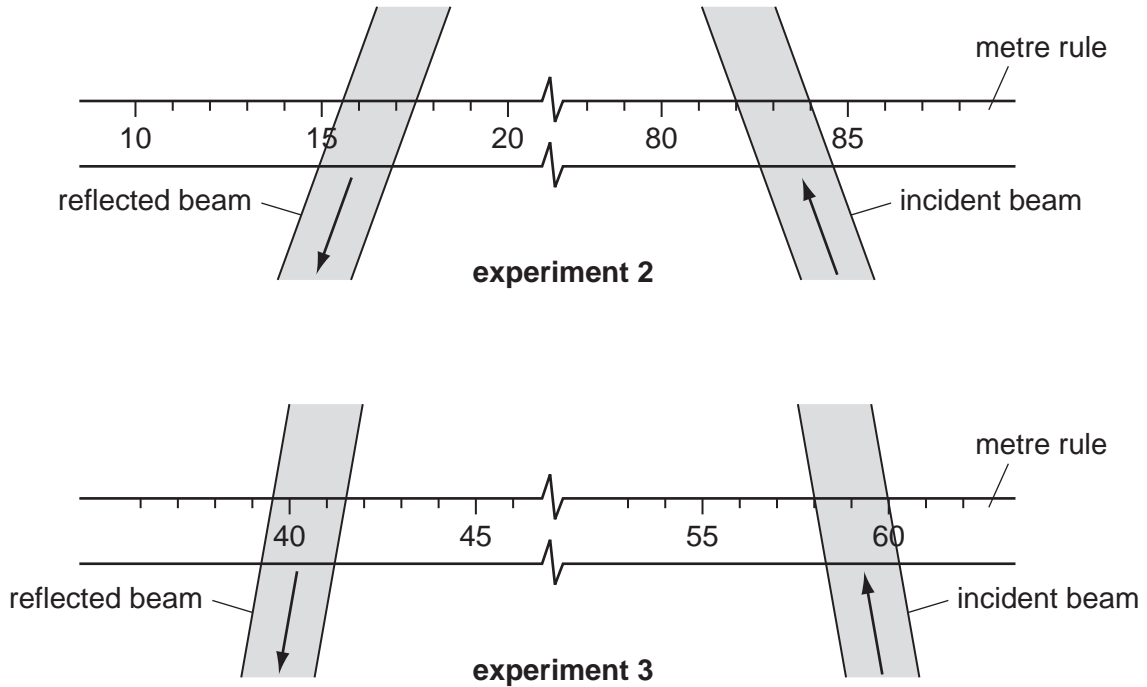

Fig. 2.3

(b) Explain how the results illustrate the laws of reflection at a plane mirror.

.....

.....

..... [2]

- (c) The student places a parallel-sided glass block in the path of a beam of light. Complete Fig. 2.4 to show the path of the beam **through** and **out of** the glass block. [2]

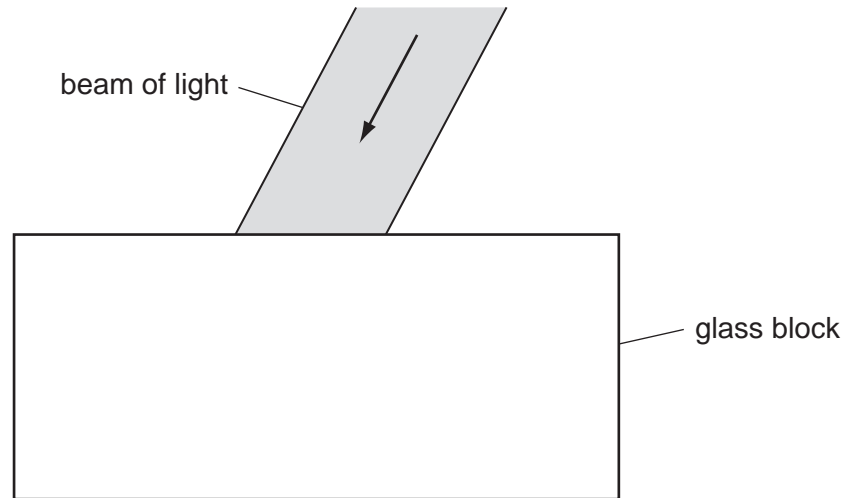

Fig. 2.4

- (d) The student places a convex lens in the path of a beam of light. The lens has a focal length of 5 cm. Fig. 2.5 shows the **actual size** of the beam. Complete Fig. 2.5 to show the path of the beam **through** and **out of** the lens. [2]

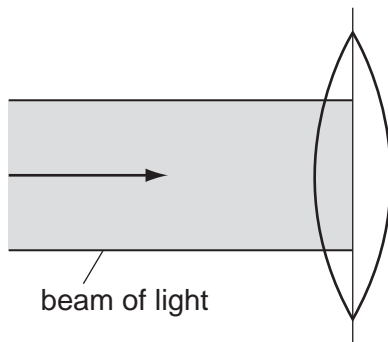

Fig. 2.5

BLANK PAGE

Turn to page 10 for Question 3

- 3 This question is about magnesium and two of its compounds. Fig. 3.1 shows how the magnesium compounds are formed.
Be careful to use the correct scientific words when you write the answers.

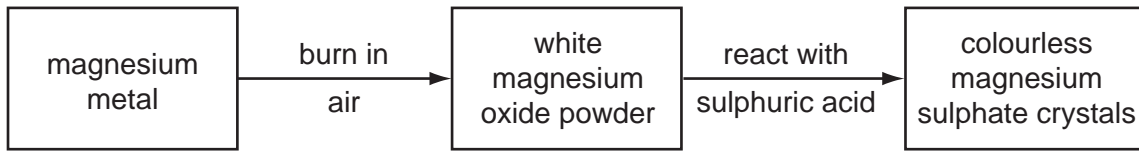

Fig. 3.1

- (a) A student burns a piece of magnesium ribbon in air.
(i) Explain how he can **safely** carry out this experiment.

.....

 [1]

He adds the white powder he has made to a test-tube half-filled with water. He shakes the tube. The mixture is cloudy.

- (ii) What does this tell him about magnesium oxide?

..... [1]

He adds Universal Indicator to the mixture from (i). The mixture turns blue.

- (iii) What does this tell him about the mixture?

..... [1]

- (b) The student half-fills a small beaker with dilute sulphuric acid. He warms the acid. He adds a spatula-full of magnesium oxide to the warm acid and stirs the mixture. The white powder disappears into the clear sulphuric acid.

- (i) What does this tell the student about magnesium oxide?

.....
 [2]

The student adds more magnesium oxide to the acid. The mixture of acid and magnesium oxide turns cloudy, like the mixture in (a)(i).

- (ii) Why does the student add magnesium oxide until the mixture is cloudy?

.....
 [1]

- (iii) Draw a diagram to show how the student obtains clear aqueous magnesium sulphate from the mixture in the beaker.

[2]

- (c) The student places the aqueous magnesium sulphate in a dish on top of a beaker half full of water. He heats the water so that it boils. After a few minutes there is still a liquid in the dish, but no solid has formed.

- (i) Why does the student heat the aqueous magnesium sulphate in this way?

.....
..... [1]

After a while, about 20 cm³ of the aqueous magnesium sulphate is left in the dish. The student stops heating and allows the dish to cool down to room temperature. Crystals of magnesium sulphate begin to form.

- (ii) Explain why the crystals now begin to form.

.....
..... [1]

- 4 Scientists use bicarbonate indicator to show changes in the concentration of carbon dioxide gas in air. In normal air the indicator is coloured orange. If the level of carbon dioxide increases it turns yellow. The indicator is purple if the level of carbon dioxide is lower than in normal air.

A student set up three tubes, as shown in Fig. 4.1. He put tube **A** in bright sunlight, tube **B** in the dark, and tube **C** was left in normal daylight. After a few hours the tubes were examined. The results are shown in Fig. 4.2.

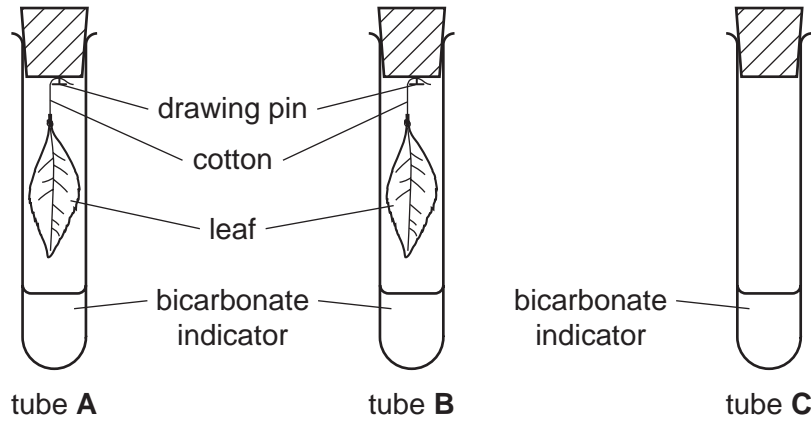

Fig. 4.1

- (a) Complete Fig. 4.2 with full explanations for the results.

tube	colour of indicator	explanation
A	purple	
B	yellow	
C	orange	

Fig. 4.2

[6]

- (b) What was the purpose of tube **C**?

.....
 [1]

- (c) The student decided to adapt the apparatus to study the effect of small invertebrates, for example woodlice, on the concentration of carbon dioxide in air. In the space below draw how he could do this.

[2]

- 5 The teacher showed the class experiments using two compounds, **X** and **Y**. The compounds were metal oxides. They were both black powders.

Experiment 1

He put 10 cm³ of hydrogen peroxide, a colourless aqueous solution, into a test-tube fitted with a delivery tube, shown in Fig. 5.1. He added a small amount of compound **X**. After a few minutes, the amount of gas collected in a graduated tube was noted. Then the experiment was repeated using compound **Y**.

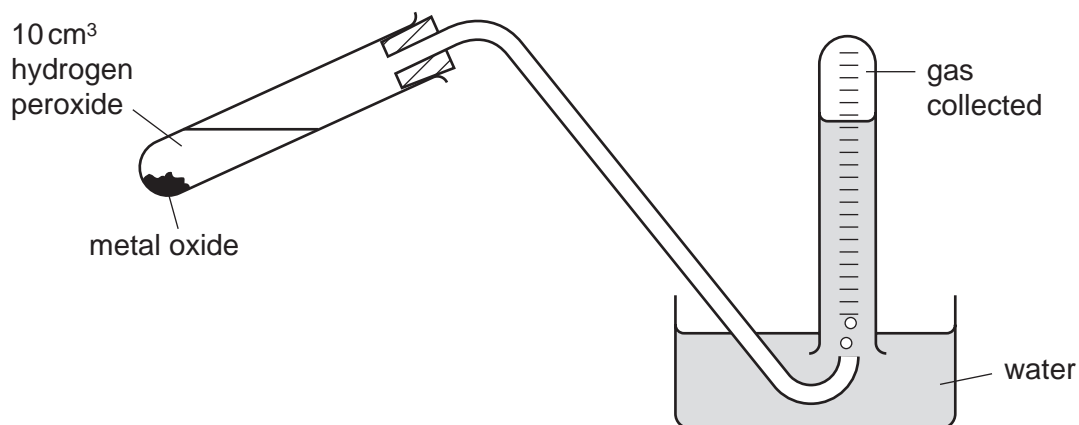

Fig. 5.1

- (a) Read the graduated tubes shown in Fig. 5.2 and record the volumes of gas given off.

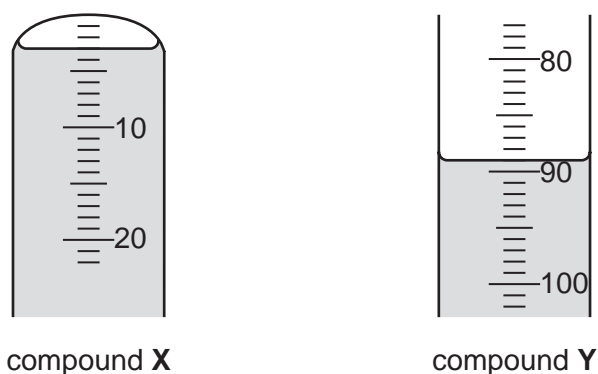

Fig. 5.2

compound **X** cm³

compound **Y** cm³

[2]

- (b) The teacher told the class that the gas collected in each tube was probably oxygen. Suggest how he can prove that the gas is oxygen.

test

result

[2]

(c) The teacher told the class that both of the black compounds acted like enzymes, decomposing hydrogen peroxide into water and oxygen. He filtered off the black compounds from the mixtures in (a). Then he dried them and added each of them to another 10 cm³ of hydrogen peroxide using apparatus identical to that shown in Fig. 5.1.

(i) Will the volumes of oxygen given off be **smaller than**, **larger than**, or **the same as** the volumes shown in Fig. 5.2?

..... [1]

(ii) Explain your answer to (i).

.....
..... [1]

Experiment 2

The teacher placed about 5 cm³ of dilute hydrochloric acid in a test-tube. He added a little of black compound **X** and then warmed the tube. After the mixture had cooled down he added aqueous sodium hydroxide until there was no further change.

He repeated the experiment using black compound **Y**.

Fig. 5.3 shows the observations made by the class.

test	observation using compound X	observation using compound Y
warm with dilute hydrochloric acid	black compound X dissolves a blue solution is made	black compound Y dissolves a gas is given off that bleaches litmus paper
add aqueous sodium hydroxide	a light blue precipitate	a dirty white precipitate

Fig. 5.3

(d) (i) Suggest the identity of the gas that bleaches litmus paper.

..... [1]

(ii) Black compound **X** dissolved giving a blue solution. Suggest the name of the ions that cause it to be blue.

..... [1]

(iii) Explain how you would use aqueous ammonia to confirm the presence of the named metal ion in the blue solution.

.....
.....
..... [2]

- 6 A student sets up the circuit shown in Fig. 6.1. Two lamps are in series.

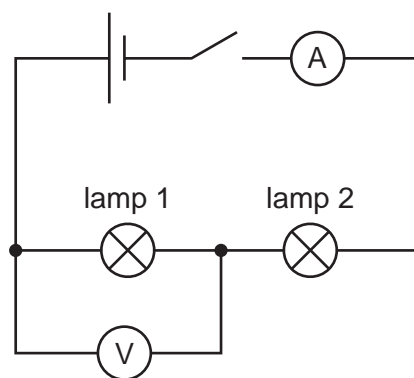

Fig. 6.1

- (a) He closes the switch and reads the ammeter.
Read the ammeter dial shown in Fig. 6.2 and record the current, I , in Fig. 6.3. [1]

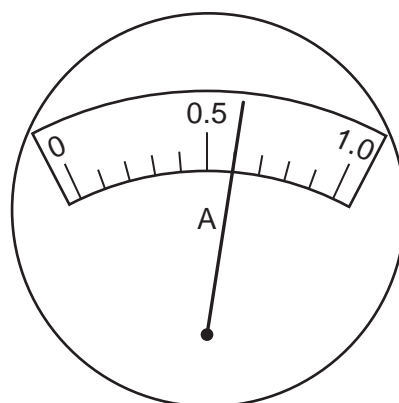

Fig. 6.2

current I through the circuit / A	
voltage across lamp 1 / V	
voltage across lamp 2 / V	

Fig. 6.3

- (b) The student reads the voltage across lamp 1 using the voltmeter shown in Fig. 6.1. Then he re-connects the voltmeter to show the voltage across lamp 2. Read the voltmeter dials shown in Fig. 6.4 and record the values in Fig. 6.3. [2]

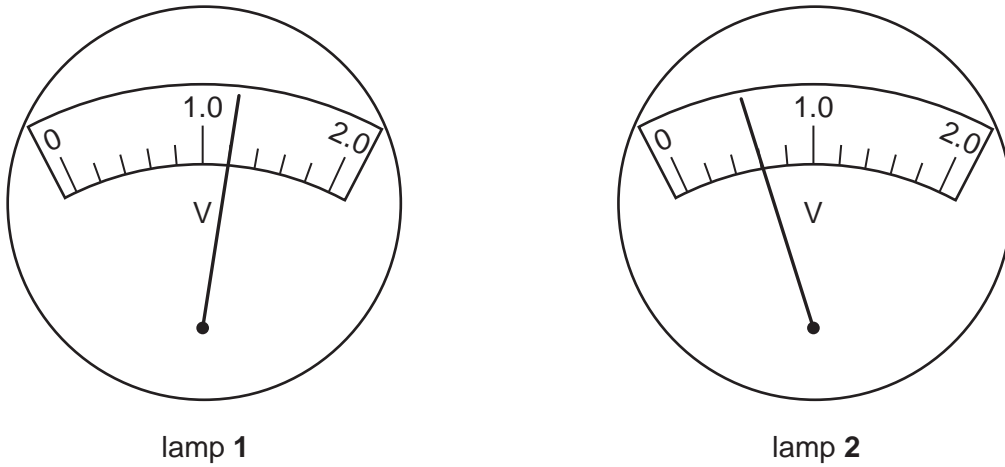

Fig. 6.4

- (c) Use the equation $R = \frac{V}{I}$ and the values you have recorded in Fig. 6.3 to calculate the resistances of lamp 1 and lamp 2. Give the units of resistance.

resistance of lamp 1 =

resistance of lamp 2 =

name of the unit of resistance =

[3]

- (d) The student thought it was possible to increase the brightness of both the lamps by rearranging the circuit shown in Fig. 6.1.
 - (i) Draw a circuit diagram to show how this might be done. Do **not** include the voltmeter in your circuit.

[2]

- (ii) Explain why the lamps would be brighter using the circuit you have drawn.

.....

.....

..... [2]

BLANK PAGE

BLANK PAGE

Permission to reproduce items where third-party owned material protected by copyright is included has been sought and cleared where possible. Every reasonable effort has been made by the publisher (UCLES) to trace copyright holders, but if any items requiring clearance have unwittingly been included, the publisher will be pleased to make amends at the earliest possible opportunity.

University of Cambridge International Examinations is part of the Cambridge Assessment Group. Cambridge Assessment is the brand name of University of Cambridge Local Examinations Syndicate (UCLES), which is itself a department of the University of Cambridge.