

Centre Number

Candidate Number

Name

CAMBRIDGE INTERNATIONAL EXAMINATIONS  
International General Certificate of Secondary Education

**CO-ORDINATED SCIENCES**

**0654/02**

Paper 2

October/November 2003

**2 hours**

Candidates answer on the Question Paper.  
No Additional Materials are required.

**READ THESE INSTRUCTIONS FIRST**

Write your Centre number, candidate number and name on all the work you hand in.  
Write in dark blue or black pen in the spaces provided on the Question Paper.  
You may use a soft pencil for any diagrams, graphs, tables or rough working.  
Do not use staples, paper clips, highlighters, glue or correction fluid.

Answer **all** questions.

At the end of the examination, fasten all your work securely together.

The number of marks is given in brackets [ ] at the end of each question or part question.

A copy of the Periodic Table is printed on page 20.

**For Examiner's Use**

1

2

3

4

5

6

7

8

9

10

11

**Total**

If you have been given a label, look at the details. If any details are incorrect or missing, please fill in your correct details in the space given at the top of this page.

Stick your personal label here, if provided.

This document consists of **19** printed pages and **1** blank page.



1 Fig. 1.1 shows some cells that are found in the lining of the trachea (windpipe).

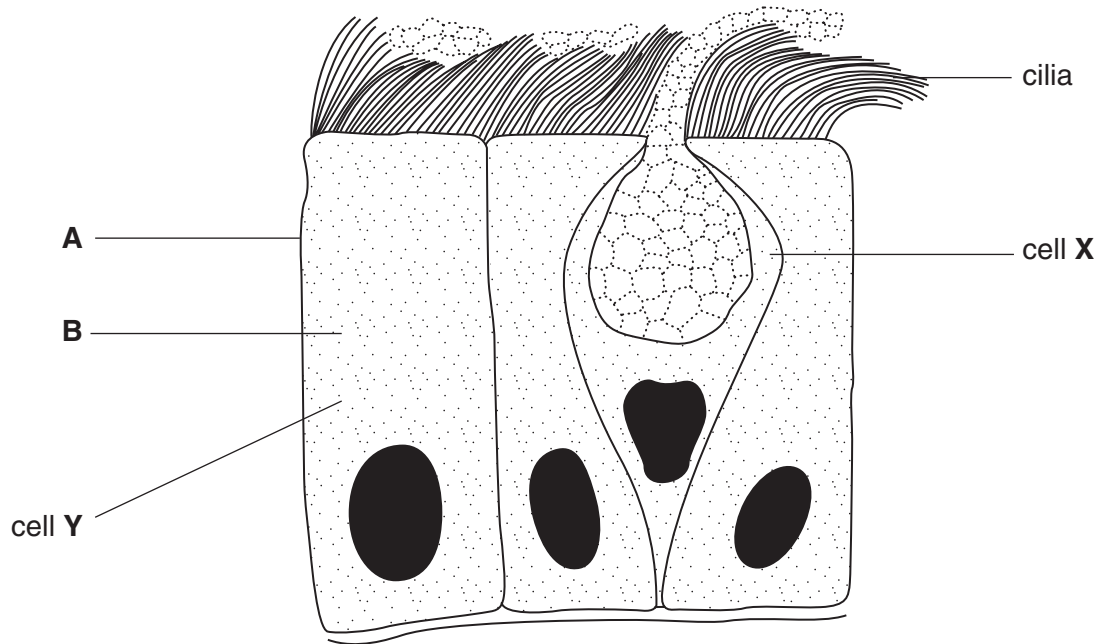

Fig. 1.1

(a) (i) Name the parts of cell Y that are labelled A and B.

A .....

B .....

[2]

(ii) How can you tell that cell Y is an animal cell and not a plant cell?

.....  
 ..... [2]

(b) Describe the function of cell X.

.....  
 .....  
 ..... [2]

(c) When a person smokes a cigarette, the cilia stop working.

Explain how this can affect the smoker's breathing system.

.....  
 .....  
 .....  
 ..... [3]

- 2 Fig. 2.1 shows an electrical circuit set up to measure the current going through a lamp and the voltage across it.

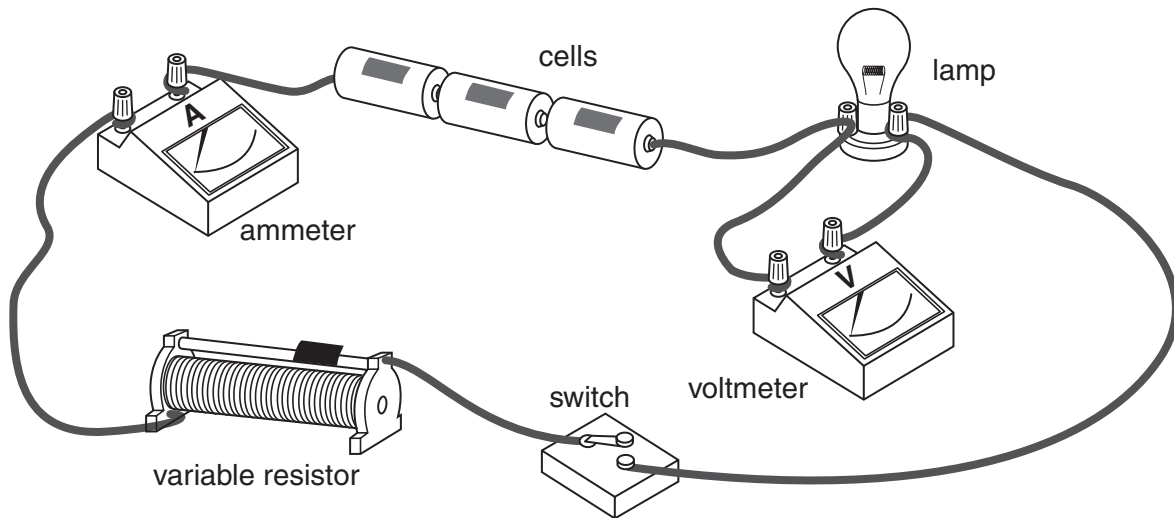

Fig. 2.1

- (a) Draw the circuit diagram for the apparatus used in this experiment.

[3]

- (b) State **one** way to increase the current in this circuit.

.....[1]

- (c) If the resistance of the variable resistor is increased, state and explain what happens to

(i) the voltmeter reading, .....

.....

(ii) the ammeter reading, .....

.....

(iii) the brightness of the lamp. ....

.....

[3]

- 3 (a) Many metals react with dilute hydrochloric acid. A general word equation for the reaction is shown below.

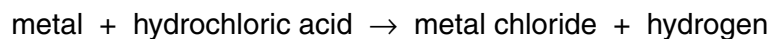

- (i) Describe the test for hydrogen.

.....  
 .....[2]

- (ii) The apparatus shown in Fig. 3.1 can be used to investigate the rate of reaction between hydrochloric acid and a metal. To start the reaction, the flask is tilted to mix the reactants.

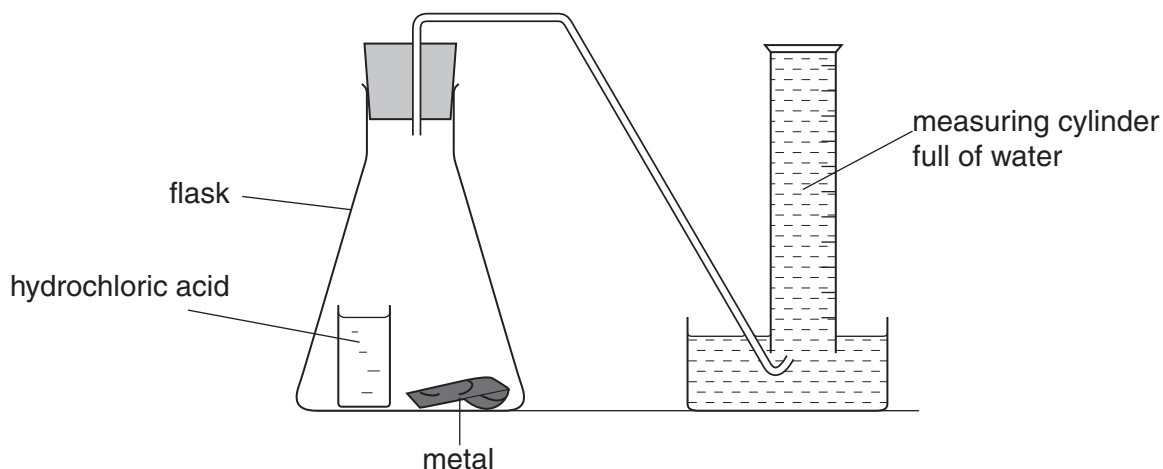

**Fig. 3.1**

Describe how the apparatus could be used to compare the rates of reaction between hydrochloric acid and two metals **A** and **B**.

.....  
 .....  
 .....  
 .....  
 .....  
 .....  
 .....  
 .....[3]

(b) The metals shown below are listed in order of their chemical reactivity.

magnesium (most reactive)

zinc

iron

tin

copper

A student carried out an experiment to investigate rusting of iron nails. He joined small pieces of different metals to identical iron nails and placed the nails in open test-tubes which contained a little water. The observations that the student made some days later are shown in Fig. 3.2.

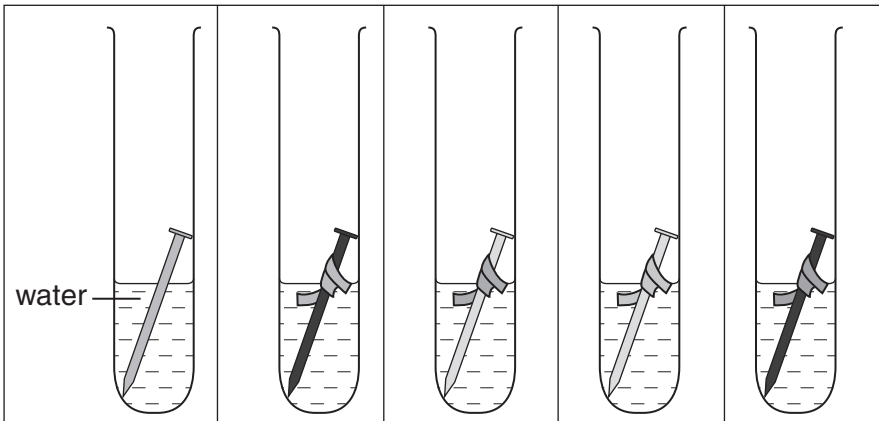

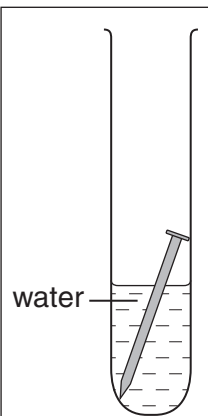
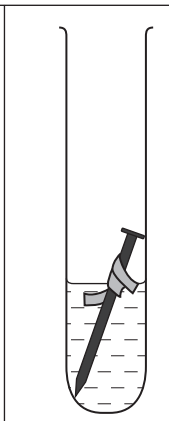
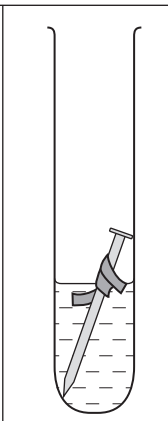
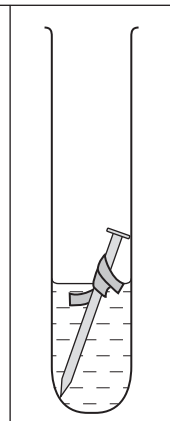
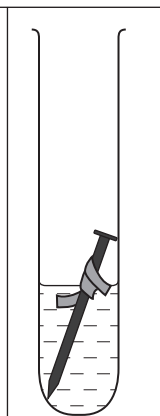
					
metal joined to nail	none (control)	tin	magnesium	zinc	copper
observation	slight rust	heavy rust	no rust	no rust	heavy rust

**Fig. 3.2**

What conclusions could the student draw from these observations?

.....

.....

.....

.....[2]

- 4 (a) A bat locates a moth by emitting a pulse of ultrasound as shown in Fig. 4.1. The pulse takes 0.2 seconds to reach the moth and return to the bat after reflection. The speed of ultrasound waves in air is 330 m/s.

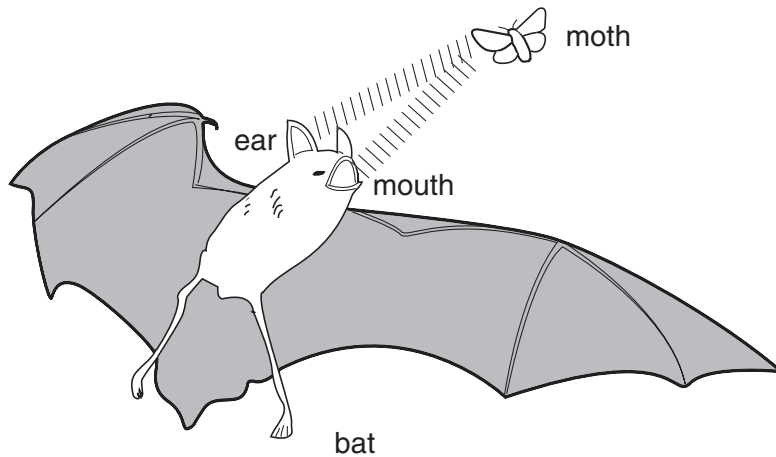

**Fig. 4.1**

- (i) Calculate the distance between the moth and the bat. State the formula that you use and show your working.

formula

working

.....m [3]

- (ii) Ultrasound waves travel through the air like sound waves. Explain how these waves travel.

.....

.....

.....[2]

- (iii) Ultrasound waves from a bat have the same amplitude as the sound wave shown on the oscilloscope trace in Fig. 4.2, but a higher frequency.

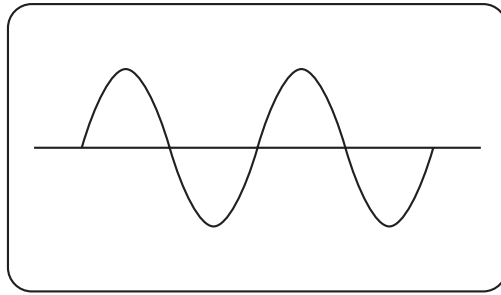

**Fig. 4.2**

On Fig. 4.3, sketch the trace that would be produced by the ultrasound waves from a bat.



**Fig. 4.3**

[2]

- (b) A locust of mass 2.5 g jumps at a speed of 3 m/s. Calculate the kinetic energy of the locust at this moment. State the formula that you use and show your working.

formula

working

.....J [3]

- 5 Whenever a person eats food, small amounts of the food are left on and between the teeth. Bacteria in the mouth feed on this, producing acids.

(a) Fig. 5.1 shows the pH in a boy's mouth from the time that he got up to when he went to bed.

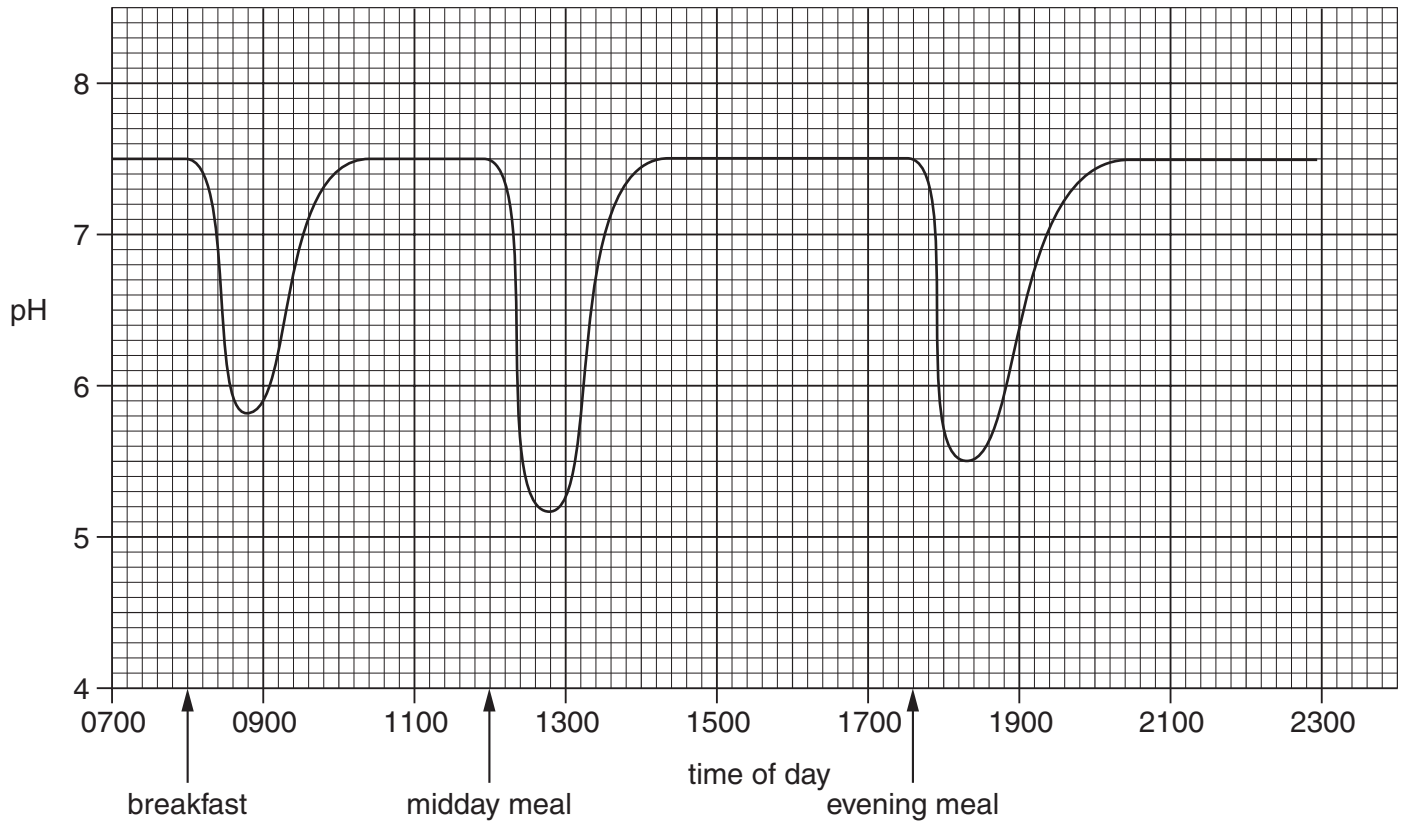

**Fig. 5.1**

(i) What is the normal pH in the boy's mouth?

.....

[1]

(ii) Explain why the pH dropped just after midday.

.....

.....

.....[2]



(iii) Toothpastes contain a weak alkali. On Fig. 5.1, draw a line to show what the pH in the mouth might be between 08:00 and 12:00 if the boy had cleaned his teeth immediately after breakfast. [1]

(iv) With reference to Fig. 5.1 and your own knowledge, explain how cleaning your teeth can prevent tooth decay.

.....  
.....  
.....  
.....[3]

(b) Fig. 5.2 shows the teeth on one side of a person's lower jaw.

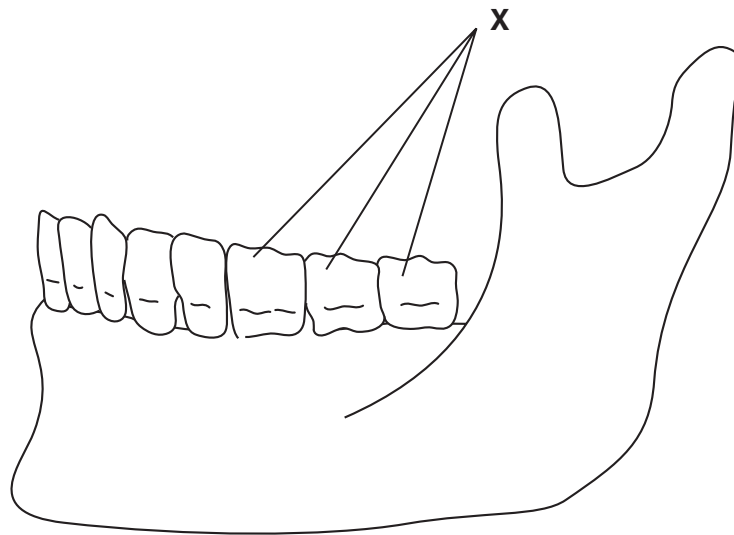

Fig. 5.2

(i) On Fig. 5.2, label an incisor tooth. [1]

(ii) Describe the function of the teeth labelled X.

.....  
.....  
.....[2]

(iii) Tooth decay is more common in the teeth labelled X than in other teeth. Suggest why this is so.

.....  
.....  
.....[2]

- 6 Silicon is an important element used to make microchips for electronic devices. Silicon is obtained from silicon dioxide,  $\text{SiO}_2$ , found in the Earth's crust.

(a) (i) Name a **non-metallic** element in the same period of the Periodic Table as silicon.

.....[1]

(ii) Name a **metallic** element in the same group of the Periodic Table as silicon.

.....[1]

(iii) State the number of electrons in the outer shell of a silicon atom. Explain how you obtained your answer.

.....

.....

.....[2]

(b) Glass is made by melting a mixture of silicon dioxide and metal oxides. Two mixtures, **A** and **B**, used to make glass are shown below.

mixture <b>A</b>	mixture <b>B</b>
silicon dioxide	silicon dioxide
calcium oxide	calcium oxide
sodium oxide	sodium oxide
	iron oxide

(i) Suggest and explain a visible difference in the appearance of the two types of glass made from these mixtures.

.....

.....

.....[2]

(ii) Underline **two** phrases in the following list that correctly describe the structure of glass.

**disorderly arrangement of atoms**

**atoms regularly arranged**

**simple molecules**

**giant structure**

[2]

- (c) The raw materials used to make glass have to be extracted from the Earth. In some countries much waste glass is re-cycled. Fig. 6.1 shows some information about the energy needed to produce one kilogram of new glass.

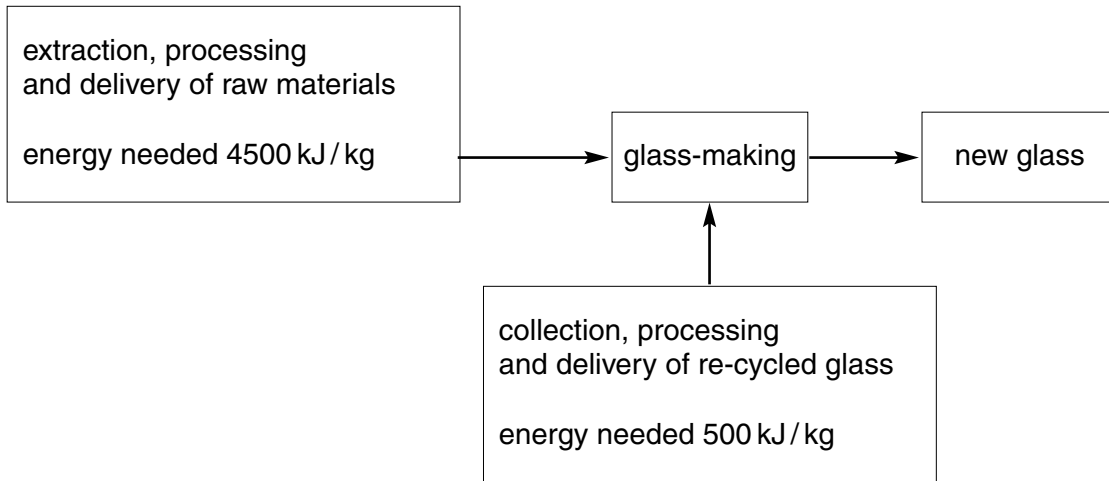

**Fig. 6.1**

Suggest two advantages of re-cycling waste glass.

- 1 .....
- .....
- 2 .....
- .....[2]

- 7 (a) Fig. 7.1 shows what happens to rays of white light that are shone at two objects, **A** and **B**.

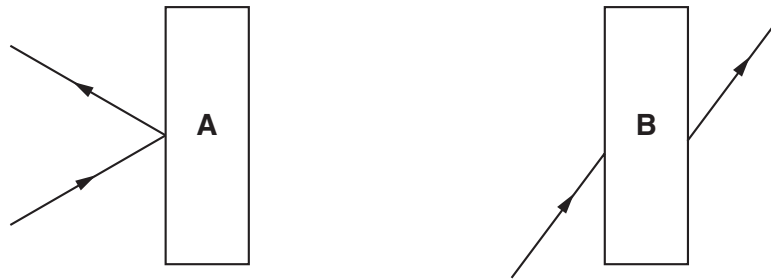

Fig. 7.1

Suggest what objects **A** and **B** might be. Explain your answers.

**A** .....

.....

.....

**B** .....

.....

.....[4]

- (b) Fig. 7.2 shows a ray of light entering an optical fibre.

Complete the diagram in Fig. 7.2 to show what happens to the ray.

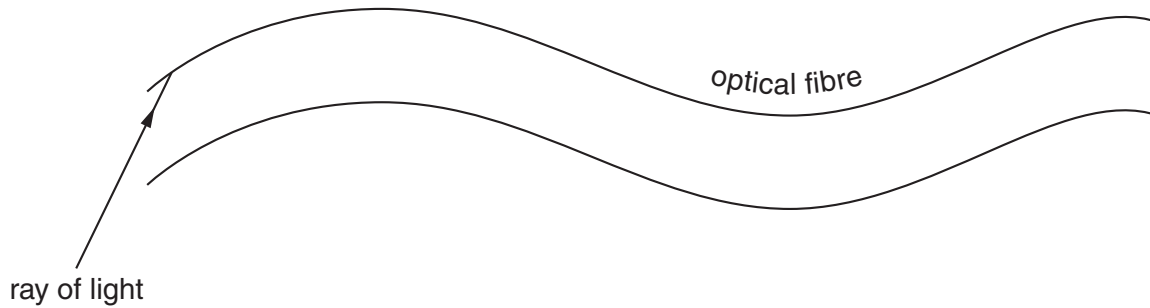

Fig. 7.2

[3]

8 To the people of ancient Greece the word *element* meant earth, air, fire or water.

(a) (i) Which of the ancient Greek “elements” would be described today as

a compound, .....

a gaseous mixture, .....

evidence of a chemical reaction? ..... [3]

(ii) Use an example of your choice to explain the meaning of the term *element* as it is used in modern Chemistry.

example .....

meaning .....

.....

.....[2]

(b) The people of ancient Greece used the word *atom* to describe a tiny particle that could not be broken into anything smaller.

Fig. 8.1 shows a diagram of an atom as it is understood today.

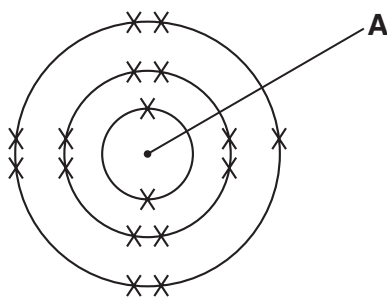

Fig. 8.1

(i) Name the particles present in part A.

.....[2]

(ii) Name the particle represented by the symbol X

.....[1]

(iii) Describe briefly what happens when the atom shown in Fig. 8.1 changes into an ion.

.....

.....[1]

9 (a) Complete the **word** equation for photosynthesis.

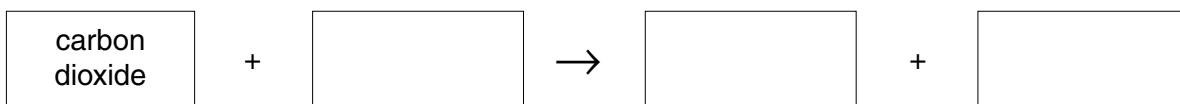

[2]

(b) Describe the role of chlorophyll in photosynthesis.

.....

.....

.....[2]

(c) Some of the substances that are made in photosynthesis are converted into a sugar called sucrose. The sucrose is transported around the plant.

(i) Name the tissue in which sucrose is transported in the plant.

.....[1]

(ii) Some of the sucrose is transported to the flowers of the plant.

Suggest and explain **one** reason why flowers need sugar.

.....

.....

.....[2]

(d) (i) With reference to the photosynthesis equation in (a), explain why deforestation could contribute to global warming.

.....

.....

.....

.....

.....[3]

(ii) Describe **one** other way in which deforestation can endanger living organisms.

.....

.....

.....[2]

**Turn over for Question 10**

10 A skier is pulled up a mountain slope by a cable as shown in Fig. 10.1.

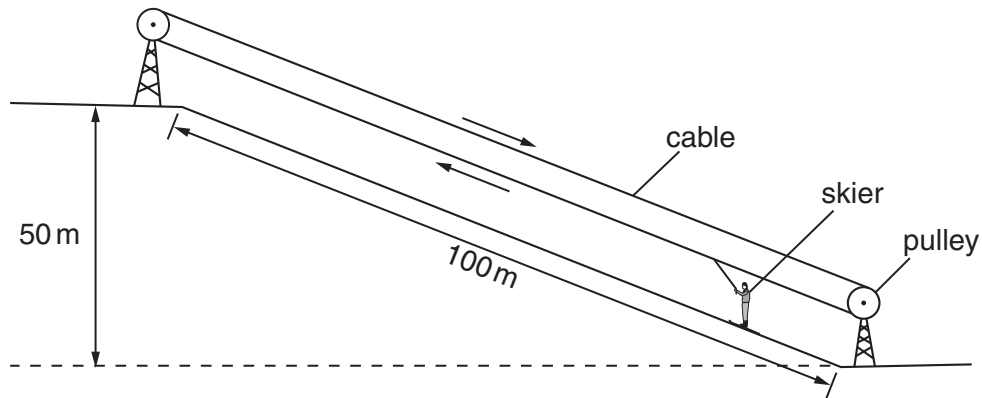

Fig. 10.1

(a) The skier weighs 650 N. She travels 100 m along the slope and rises a vertical height of 50 m.

(i) Calculate the work done in lifting the skier to the top of the slope. You should ignore work done against friction.  
State the formula that you use and show your working.

formula

working

.....J [3]

(ii) What form of energy did the skier gain by travelling to the top of the slope?

.....[1]



- (b) Skiers use a stick in each hand to help control their motion. The sticks work best when they only go a few centimetres into the snow.

Fig. 10.2 shows a skier using ski sticks.

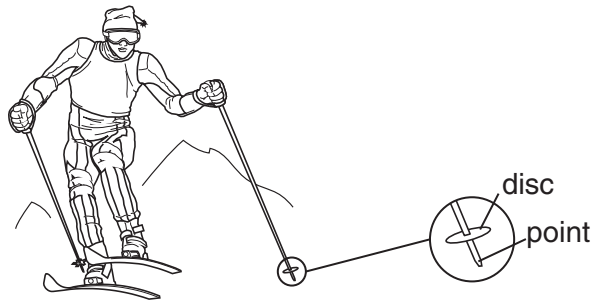

**Fig. 10.2**

Explain, using the terms pressure, force and area,

- (i) why the ski stick has a pointed end,

.....  
 .....  
 .....[2]

- (ii) why the stick has a disc a few centimetres above the pointed end.

.....  
 .....  
 .....[2]

- (c) Why does the skier keep the lower surface of her skis smooth and well polished?

.....  
 .....[1]

11 Limestone is a rock containing calcium carbonate. Limestone may suffer both physical and chemical weathering.

(a) Describe **one** process that causes the **physical** weathering of limestone.

.....  
 .....  
 .....[2]

(b) Rainwater reacts with limestone to form a solution of calcium hydrogencarbonate. This causes the water to become hard.

(i) State two disadvantages of hard water.

1 .....  
 .....  
 2 .....  
 .....[2]

(ii) State **one** method of softening hard water containing calcium hydrogencarbonate.

.....  
 .....[1]

(c) Fig. 11.1 shows a simplified diagram of a lime kiln which is used to convert calcium carbonate into calcium oxide.

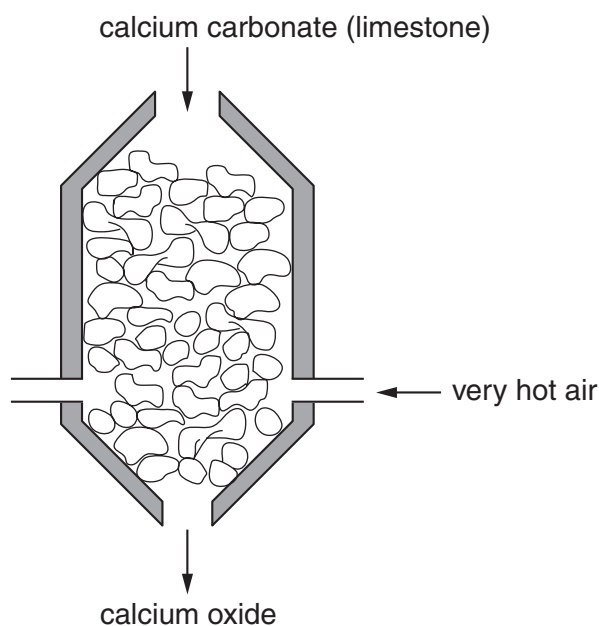

Fig. 11.1

The balanced equation for the reaction in the lime kiln is



- (i) Name the type of chemical reaction that produces calcium oxide in the lime kiln.

.....[1]

- (ii) Describe briefly how dilute hydrochloric acid could be used to show that a rock contains a carbonate.

.....

.....

.....[2]

**DATA SHEET**  
**The Periodic Table of the Elements**

		Group										
I	II	III	IV	V	VI	VII	O					
		1 <b>H</b> Hydrogen 1										4 <b>He</b> Helium 2
7 <b>Li</b> Lithium 3	9 <b>Be</b> Beryllium 4		11 <b>B</b> Boron 5	12 <b>C</b> Carbon 6	14 <b>N</b> Nitrogen 7	16 <b>O</b> Oxygen 8	19 <b>F</b> Fluorine 9	20 <b>Ne</b> Neon 10				
23 <b>Na</b> Sodium 11	24 <b>Mg</b> Magnesium 12		27 <b>Al</b> Aluminium 13	28 <b>Si</b> Silicon 14	31 <b>P</b> Phosphorus 15	32 <b>S</b> Sulphur 16	35.5 <b>Cl</b> Chlorine 17	40 <b>Ar</b> Argon 18				
39 <b>K</b> Potassium 19	40 <b>Ca</b> Calcium 20		70 <b>Ga</b> Gallium 31	65 <b>Zn</b> Zinc 30	59 <b>Ni</b> Nickel 28	64 <b>Cu</b> Copper 29	65 <b>Zn</b> Zinc 30	84 <b>Kr</b> Krypton 36				
85 <b>Rb</b> Rubidium 37	88 <b>Sr</b> Strontium 38		115 <b>In</b> Indium 49	112 <b>Cd</b> Cadmium 48	106 <b>Pd</b> Palladium 46	108 <b>Ag</b> Silver 47	112 <b>Cd</b> Cadmium 48	131 <b>Xe</b> Xenon 54				
133 <b>Cs</b> Caesium 55	137 <b>Ba</b> Barium 56		204 <b>Tl</b> Thallium 81	201 <b>Hg</b> Mercury 80	195 <b>Pt</b> Platinum 78	197 <b>Au</b> Gold 79	201 <b>Hg</b> Mercury 80	186 <b>Rn</b> Radon 86				
226 <b>Ra</b> Radium 88	227 <b>Ac</b> Actinium 89		204 <b>Tl</b> Thallium 81	201 <b>Hg</b> Mercury 80	195 <b>Pt</b> Platinum 78	197 <b>Au</b> Gold 79	201 <b>Hg</b> Mercury 80	186 <b>Rn</b> Radon 86				
*58-71 Lanthanoid series												
†90-103 Actinoid series												
<div style="display: flex; justify-content: space-between; align-items: center;"> <div style="border: 1px solid black; padding: 5px;"> <math>a</math> <b>X</b> <math>b</math> </div> <div style="text-align: right;"> <math>a</math> = relative atomic mass  <math>X</math> = atomic symbol  <math>b</math> = proton (atomic) number         </div> </div>												
140 <b>Ce</b> Cerium 58	141 <b>Pr</b> Praseodymium 59	144 <b>Nd</b> Neodymium 60	150 <b>Sm</b> Samarium 62	152 <b>Eu</b> Europium 63	157 <b>Gd</b> Gadolinium 64	162 <b>Dy</b> Dysprosium 66	165 <b>Ho</b> Holmium 67	167 <b>Er</b> Erbium 68	169 <b>Tm</b> Thulium 69	173 <b>Yb</b> Ytterbium 70	175 <b>Lu</b> Lutetium 71	
232 <b>Th</b> Thorium 90	238 <b>Pa</b> Protactinium 91	238 <b>U</b> Uranium 92	94 <b>Pu</b> Plutonium 94	95 <b>Am</b> Americium 95	96 <b>Cm</b> Curium 96	98 <b>Cf</b> Californium 98	99 <b>Es</b> Einsteinium 99	100 <b>Fm</b> Fermium 100	101 <b>Md</b> Mendelevium 101	102 <b>No</b> Nobelium 102	103 <b>Lr</b> Lawrencium 103	

The volume of one mole of any gas is 24 dm<sup>3</sup> at room temperature and pressure (r.t.p.).