



UNIVERSITY OF CAMBRIDGE INTERNATIONAL EXAMINATIONS
International General Certificate of Secondary Education

www.XtremePapers.com

CO-ORDINATED SCIENCES

0654/01

Paper 1 Multiple Choice

October/November 2009

45 minutes

Additional Materials: Multiple Choice Answer Sheet
Soft clean eraser
Soft pencil (type B or HB is recommended)



READ THESE INSTRUCTIONS FIRST

Write in soft pencil.

Do not use staples, paper clips, highlighters, glue or correction fluid.

Write your name, Centre number and candidate number on the Answer Sheet in the spaces provided unless this has been done for you.

There are **forty** questions on this paper. Answer **all** questions. For each question there are four possible answers **A, B, C** and **D**.

Choose the **one** you consider correct and record your choice in **soft pencil** on the separate Answer Sheet.

Read the instructions on the Answer Sheet very carefully.

Each correct answer will score one mark. A mark will not be deducted for a wrong answer.

Any rough working should be done in this booklet.

A copy of the Periodic Table is printed on page 20.

This document consists of **17** printed pages and **3** blank pages.



1 An animal is observed swimming in a river. It has legs, but no fins. Its skin is scaly.

To which class of vertebrates does this animal belong?

- A amphibians
- B fish
- C mammals
- D reptiles

2 The diagram shows a plant cell that has been placed in a concentrated solution for 30 minutes.

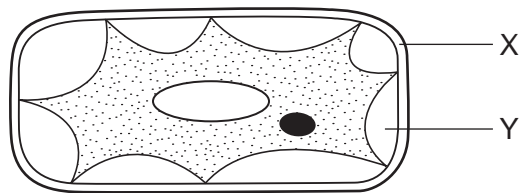

What identifies X and Y?

	X	Y
A	cell membrane	air
B	cell membrane	concentrated solution
C	cell wall	air
D	cell wall	concentrated solution

3 The diagram shows a cross section of a leaf.

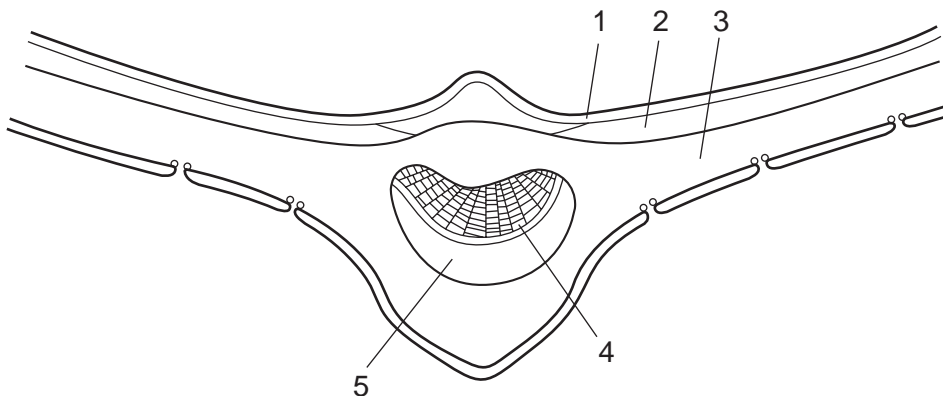

In which two parts of the leaf does photosynthesis take place?

- A 1 and 3
- B 2 and 3
- C 3 and 4
- D 4 and 5

4 How do goblet cells and cilia help to keep the lungs free from infection?

	goblet cells	cilia
A	form a secretion that kills viruses	cough up the dead viruses
B	make a fluid that traps bacteria	move the fluid from the bronchioles
C	produce saliva	move saliva from the lungs to the mouth
D	secrete mucus that bacteria stick to	pump mucus out of the alveoli

5 The diagram shows a section through the heart with blood vessels, seen from the front.

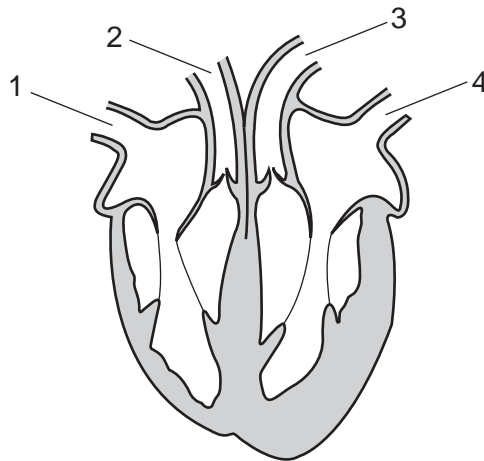

In one circulation of the body, **excluding the lungs**, in which order does blood flow through the vessels shown?

- A** 1 → 2 → 4 → 3
- B** 2 → 3 → 1 → 4
- C** 3 → 4 → 1 → 2
- D** 4 → 3 → 1 → 2

6 What happens during anaerobic respiration in muscle cells?

	oxygen used	waste products
A	no	carbon dioxide and water
B	no	lactic acid
C	yes	carbon dioxide and water
D	yes	lactic acid

7 The diagram shows parts of the digestive system.

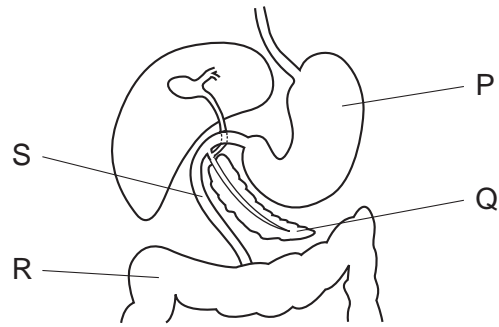

Which labelled parts are the small intestine and the pancreas?

- A** P and Q **B** Q and R **C** S and R **D** S and Q

8 The diagram shows a section through the front of the eye.

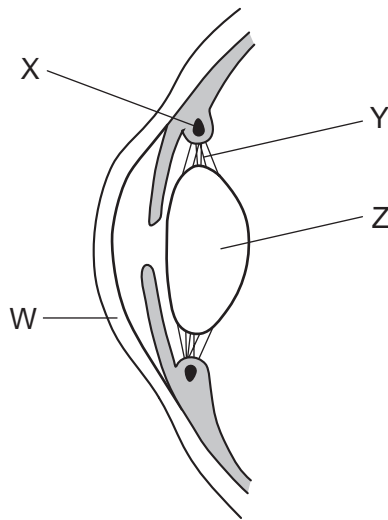

Where are muscles found?

	W	X	Y	Z
A	x	✓	x	x
B	x	✓	✓	✓
C	✓	x	✓	x
D	✓	✓	x	x

key

✓ = found

x = not found

9 The diagram shows a section through a bean seed.

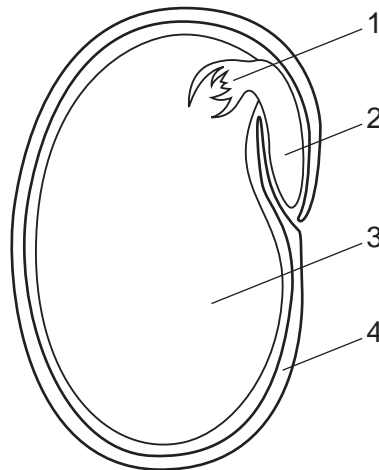

Which numbers identify the parts of the seed?

	cotyledon	plumule	radicle	testa
A	2	1	4	3
B	2	3	4	1
C	3	1	2	4
D	3	2	1	4

10 Which structure contracts while a baby is being born?

- A** cervix
- B** placenta
- C** umbilical cord
- D** uterus

11 What are clones?

- A** organisms which are heterozygous
- B** organisms which are homozygous
- C** organisms with the same genotype
- D** organisms with the same phenotype

12 The diagram shows a food chain. The arrows show the flow of energy between organisms.

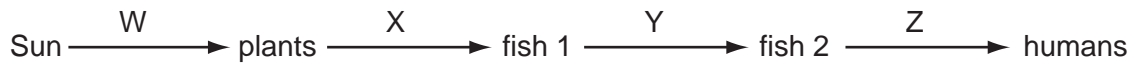

Where will energy loss occur?

- A from W only
- B from W, X and Y only
- C from X, Y and Z only
- D from W, X, Y and Z

13 The diagram shows part of the water cycle.

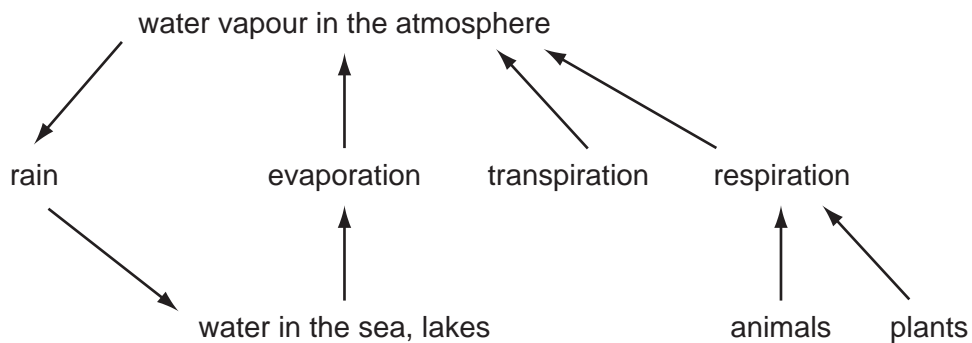

Which returns most water to the atmosphere?

- A evaporation from the sea and lakes
- B respiration from animals
- C respiration from plants
- D transpiration

14 Element X can form four covalent bonds. Element Y can form two covalent bonds.

What is the simplest formula of the compound formed by X and Y?

- A XY_2
- B X_2Y
- C X_2Y_4
- D X_4Y_2

15 Element X forms a basic oxide.

How should X be described?

	type of element	position in the Periodic Table
A	metal	on the left
B	metal	on the right
C	non-metal	on the left
D	non-metal	on the right

16 Catalytic cracking is useful in the petrochemical industry.

Which two of the listed equations are possible cracking reactions?

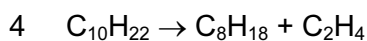
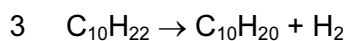
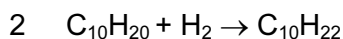
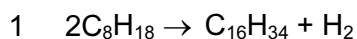

A 1 and 3

B 1 and 4

C 2 and 3

D 3 and 4

17 Which statement about cellulose is **not** correct?

A It is used to make paper.

B It is a carbohydrate.

C It is used to make glass.

D It is a natural polymer.

18 Why is carbon used to extract some metals from their oxide ores?

A It oxidises the ore by removing oxygen.

B It prevents the oxygen of the air reacting with the ore.

C It reacts with impurities in the ore.

D It reduces the ore by removing oxygen.

19 Which process can be used to produce sodium and chlorine from the compound sodium chloride?

- A cracking
- B distillation
- C electrolysis
- D filtration

20 Tests on some 10 cm³ samples of tap water give the following results.

test	result
add 2 cm ³ of soap solution and shake	no lather
boil the tap water, add 2 cm ³ of soap solution and shake	lather
add acidified aqueous barium nitrate	white precipitate

What do the results show about the tap water?

- A It is hard and contains chloride ions.
- B It is hard and contains sulfate ions.
- C It is soft and contains chloride ions.
- D It is soft and contains sulfate ions.

21 An acid reacts with an alkali.

Which type of reaction and which temperature change takes place?

	type of reaction	temperature change
A	endothermic	decrease
B	endothermic	increase
C	exothermic	decrease
D	exothermic	increase

22 What is released from rocks during weathering to help plants grow?

- A calcium hydroxide
- B nitrogen gas
- C soluble salts
- D sodium chloride

23 What is used to test for ammonia gas?

- A a lighted splint
- B aqueous sodium hydroxide
- C damp red litmus paper
- D limewater

24 Why is Aspirin said to be an analgesic?

- A It relieves pain.
- B It forms a colloid when dissolved in water.
- C It is an antacid.
- D It can be obtained from plants.

25 An experiment using olive oil and water is shown. Liquid X is added and the contents of the test-tube are shaken.

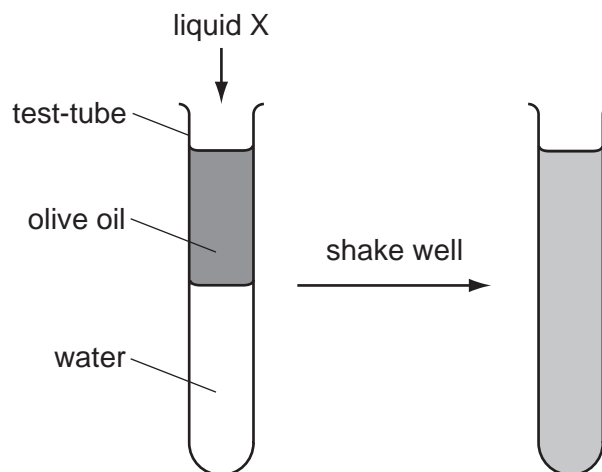

How is liquid X described?

- A a colloid
- B an emulsifier
- C a gel
- D a sol

26 An element present in fuels such as coal and coke is1.....

When the fuel is2..... this element reacts to form an3..... gas that is harmful to trees.

Which words correctly complete gaps 1, 2 and 3?

	1	2	3
A	carbon	burned	alkaline
B	carbon	distilled	acidic
C	nitrogen	reduced	alkaline
D	sulfur	burned	acidic

27 Circuits P, Q, R and S are set up as shown.

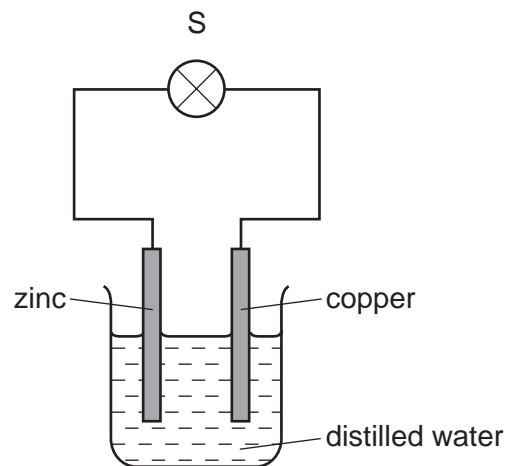
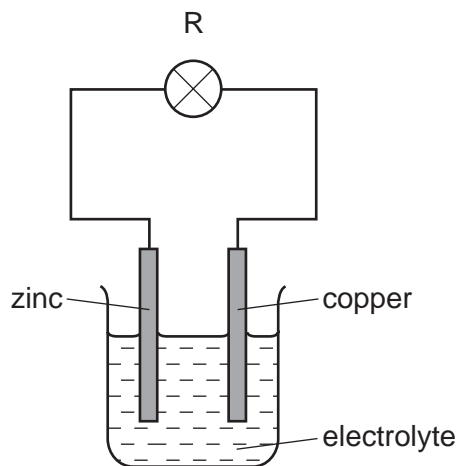
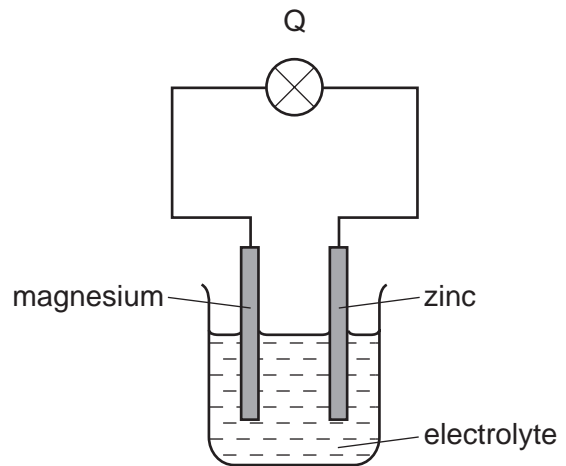
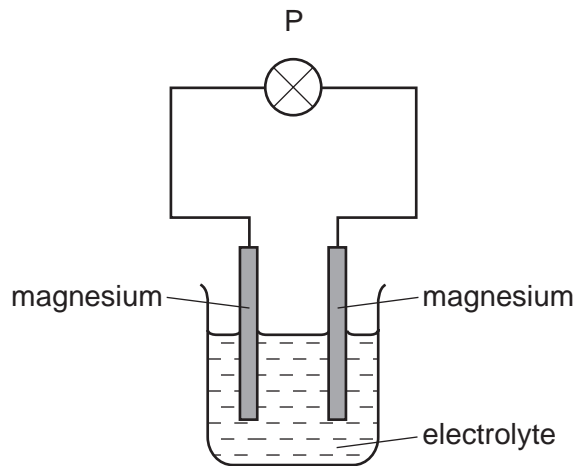

In which circuits does the lamp light?

- A P and Q only
- B Q and R only
- C R and S only
- D P, Q, R and S

- 28 A stopwatch is used to time an athlete running 100 m. The timekeeper forgets to reset the watch to zero before using it to time another athlete running 100 m.

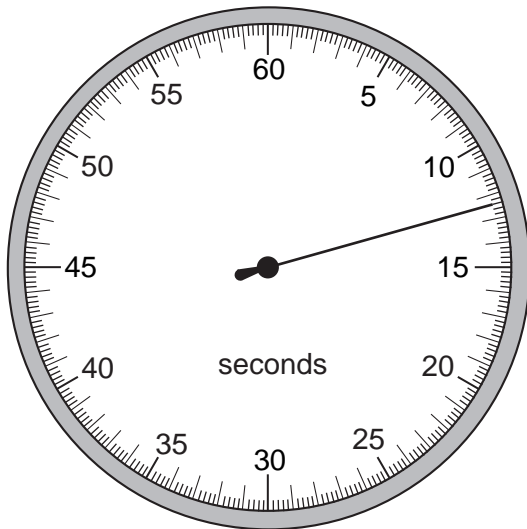

stopwatch at
end of first
athlete's run

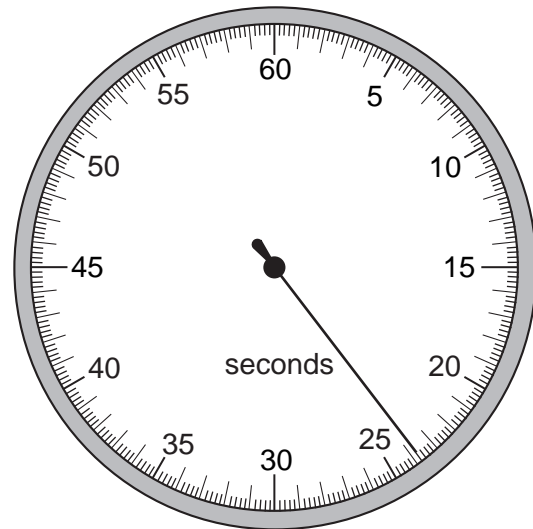

stopwatch at
end of second
athlete's run

How long does the second athlete take to run 100 m?

- A** 11.2 s **B** 11.4 s **C** 12.4 s **D** 23.8 s
- 29 Which property of a body can be measured in newtons?
- A** density
B mass
C volume
D weight

- 30 The diagrams show a rectangular box with inside measurements of 5 cm × 6 cm × 4 cm.

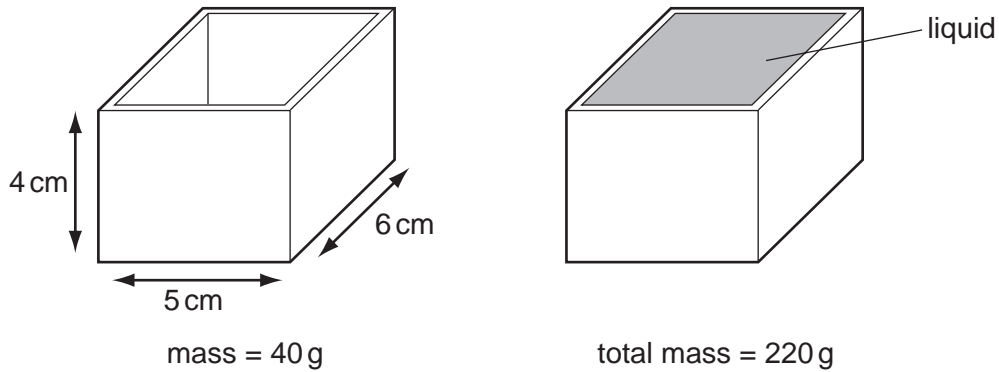

The box has a mass of 40 g when empty. When filled with a liquid it has a total mass of 220 g.

What is the density of the liquid?

- A $\frac{220}{(5 \times 6 \times 4)} \text{ g/cm}^3$
- B $\frac{(220 - 40)}{(5 \times 6 \times 4)} \text{ g/cm}^3$
- C $\frac{(5 \times 6 \times 4)}{220} \text{ g/cm}^3$
- D $\frac{(5 \times 6 \times 4)}{(220 - 40)} \text{ g/cm}^3$

- 31 The object in the diagram is acted upon by the two forces shown.

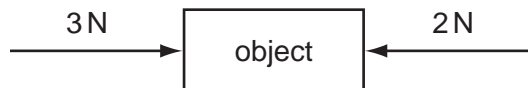

What is the effect of these forces?

- A The object moves to the left with constant speed.
- B The object moves to the left with constant acceleration.
- C The object moves to the right with constant speed.
- D The object moves to the right with constant acceleration.

32 A beaker contains water at room temperature.

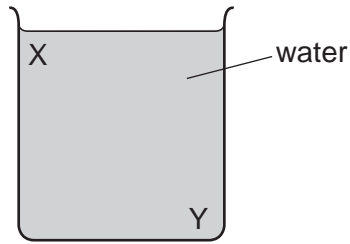

How could a convection current be set up in the water?

- A cool the water at X
- B cool the water at Y
- C stir the water at X
- D stir the water at Y

33 The drawing shows a wave.

Which labelled distance is the wavelength?

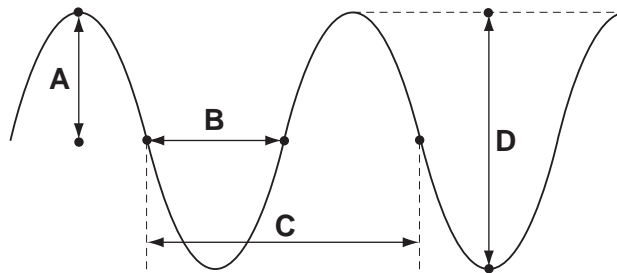

34 An object O is placed in front of a converging lens of focal length f .

At which point will the top of the image be seen?

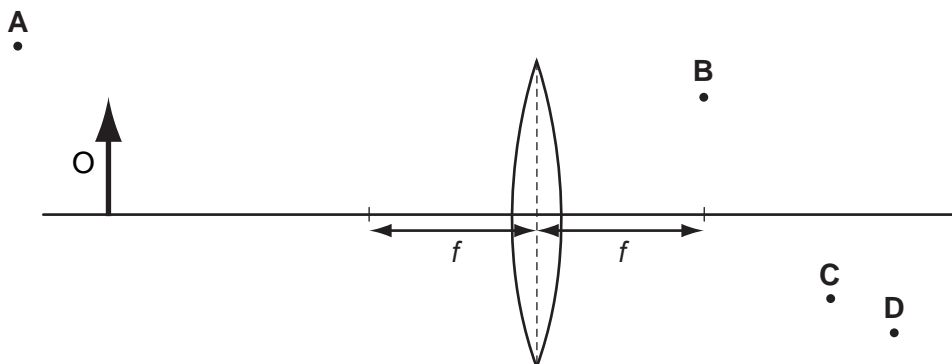

35 A pupil measures the potential difference across a device and the current in it.

Which calculation gives the resistance of the device?

- A current + potential difference
- B current \div potential difference
- C potential difference \div current
- D potential difference \times current

36 A student uses a length of wire as a resistor. He discovers that the resistance of the wire is too small.

To be certain of making a resistor of higher value, he should use a piece of wire that is

- A longer and thicker.
- B longer and thinner.
- C shorter and thicker.
- D shorter and thinner.

37 The diagram shows a battery connected to two identical resistors. Three ammeters M_1 , M_2 and M_3 are connected in the circuit.

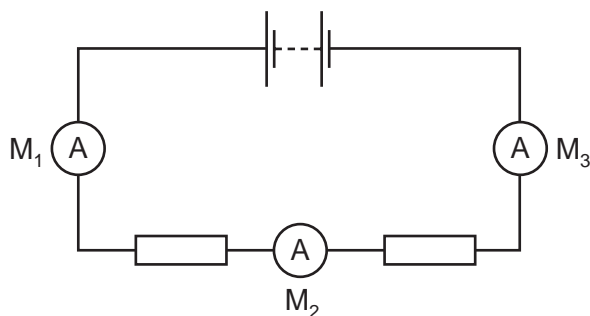

Meter M_1 reads 1.0 A.

What are the readings on M_2 and M_3 ?

	reading on M_2/A	reading on M_3/A
A	0.5	0.0
B	0.5	0.5
C	0.5	1.0
D	1.0	1.0

- 38 An electric heater is connected to the mains using insulated copper wires. The wires become very warm.

What can be done to prevent so much heat being produced in the connecting wires?

- A Use thicker copper wires.
 B Use thinner copper wires.
 C Use thicker insulation.
 D Use thinner insulation.
- 39 Which statement explains the meaning of the half-life of a radioactive substance?
- A half the time taken for half the substance to decay
 B half the time taken for the substance to decay completely
 C the time taken for half the substance to decay
 D the time taken for the substance to decay completely
- 40 The diagram shows the paths of three different types of radiation, X, Y and Z.

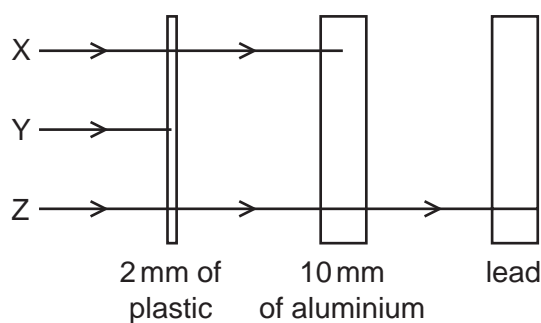

Which row in the table correctly identifies X, Y and Z?

	X	Y	Z
A	alpha radiation	beta radiation	gamma radiation
B	beta radiation	alpha radiation	gamma radiation
C	beta radiation	gamma radiation	alpha radiation
D	gamma radiation	alpha radiation	beta radiation

BLANK PAGE

