



Cambridge International Examinations
Cambridge International General Certificate of Secondary Education

CANDIDATE NAME

CENTRE NUMBER

CANDIDATE NUMBER



CO-ORDINATED SCIENCES

0654/51

Paper 5 Practical Test

October/November 2018

2 hours

Candidates answer on the Question Paper.

Additional Materials: As listed in the Confidential Instructions.

READ THESE INSTRUCTIONS FIRST

Write your Centre number, candidate number and name on all the work you hand in.
Write in dark blue or black pen.
You may use an HB pencil for any diagrams or graphs.
Do not use staples, paper clips, glue or correction fluid.
DO NOT WRITE IN ANY BARCODES.

Answer **all** questions.
Electronic calculators may be used.
You may lose marks if you do not show your working or if you do not use appropriate units.
Notes for Use in Qualitative Analysis for this paper are printed on page 12.

At the end of the examination, fasten all your work securely together.
The number of marks is given in brackets [] at the end of each question or part question.

For Examiner's Use	
1	
2	
3	
Total	

This document consists of **11** printed pages and **1** blank page.

1 You are going to investigate a leaf.

(a) In the box, make a large detailed pencil drawing of the leaf.

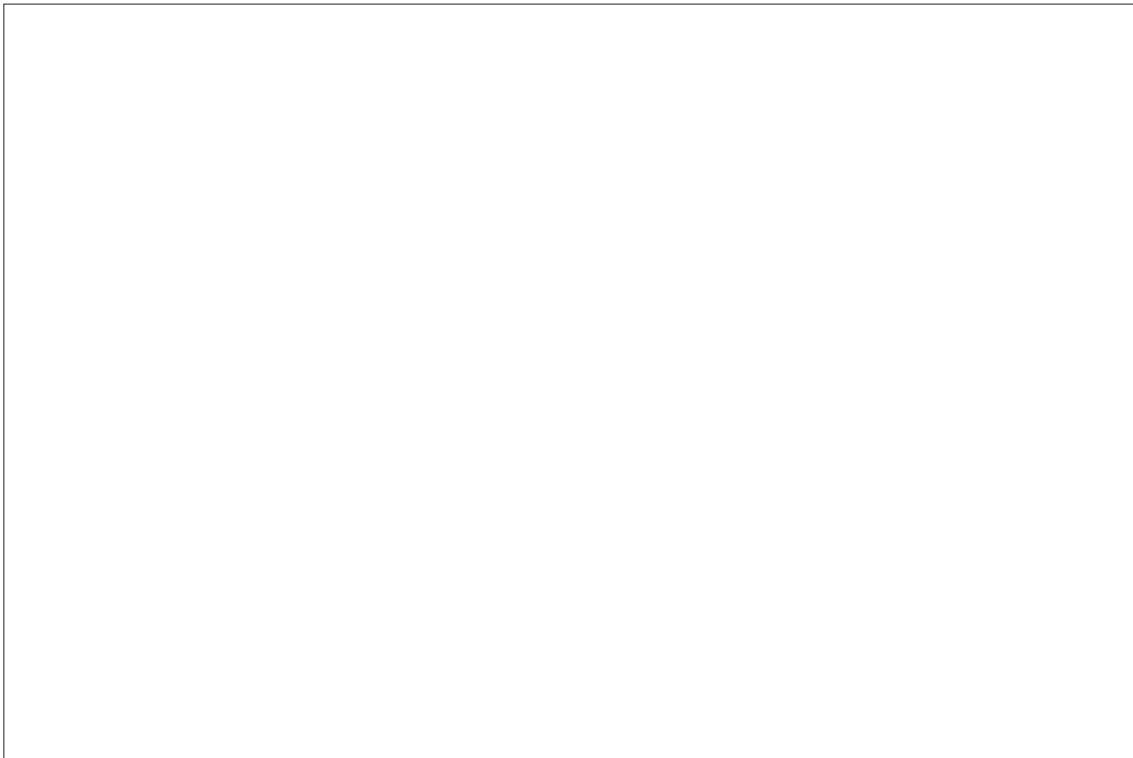

[3]

(b) (i) Measure the longest length of the leaf, not including any stalk.

Record this length, in millimetres, to the nearest millimetre.

length of leaf mm [1]

(ii) Draw a straight line to show this longest length on your drawing.

Measure and record the length of this line, in millimetres, to the nearest millimetre.

length of line on drawing mm [1]

(iii) Use your measurements from (b)(i) and (b)(ii) to calculate the magnification of your drawing.

magnification = [1]

(c) (i) Describe, in detail, the method used to test the leaf for the presence of starch.

Include the observation for a positive result.

method

.....

.....

.....

observation for a positive result

.....

[4]

(ii) Describe **and** explain one safety precaution, **not** including safety glasses, tying back hair or wearing gloves, that should be taken when carrying out this procedure.

safety precaution

explanation

[2]

(d) Leaves have stomata in the upper and lower surfaces. These can be seen using a light microscope.

A teacher says that all plants have more stomata on the lower surface of their leaves.

Plan an investigation to find out if the teacher is correct.

.....

.....

.....

.....

.....

.....

.....

.....

[3]

2 You are going to investigate the temperature changes when solid **H** reacts with solution **J**.

- (a) (i) Using the thermometer, measure the temperature T of solution **J**. Record, in Table 2.1, this value to the nearest $0.5\text{ }^{\circ}\text{C}$ in the appropriate space for time = 0 min. [1]

Table 2.1

time/min	temperature $T/^{\circ}\text{C}$
0	
0.5	
1.0	
1.5	
2.0	
2.5	
3.0	
3.5	
4.0	

(ii) **Procedure**

- Place all of solid **H** into a plastic cup supported in a beaker.
- Measure 25 cm^3 solution **J** using the measuring cylinder.
- Add the measured volume of solution **J** to the solid **H** in the plastic cup.
- Start the stopclock.
- Stir the mixture thoroughly.
- Continue stirring and measure the temperature of the mixture every half minute for four minutes.
- Record, in Table 2.1, the values to the nearest $0.5\text{ }^{\circ}\text{C}$.
- After the final reading, record in Table 2.2 the appearance of the solid and the solution.

Table 2.2

observations	solid H	solution J
before the reaction	grey	blue
after the reaction		

[4]

- (b) (i) Use the data in Table 2.1 to estimate the maximum rise in temperature ΔT of the mixture during the reaction.

ΔT $^{\circ}\text{C}$ [1]

- (ii) Explain why the value in (b)(i) is only an estimate.

.....
[1]

- (iii) Suggest how you could improve the procedure in (a)(ii) to achieve a more accurate value of the rise in temperature for this experiment without changing the apparatus or chemicals.

.....
[1]

- (c) (i) Calculate the heat energy E released in this reaction using the equation shown.

$$E = \text{volume of solution J} \times 4.2 \times \Delta T$$

Give your answer to 2 significant figures.

$$E = \dots\dots\dots \text{ joules [2]}$$

- (ii) Your value of E in (c)(i) is less than the actual amount of energy released by the reaction.

Suggest an improvement to the **apparatus** (not the chemicals) that would result in a higher value of E .

Explain why your improvement would result in a higher value of E .

improvement

.....

explanation

.....

[2]

- (d) (i) Place 1 cm depth of unused solution **J** in a test-tube and slowly add ammonia solution until in excess.

Record your observations.

.....
.....[1]

- (ii) Using your observation from (d)(i) and one other piece of evidence, identify the cation in solution **J**.

State the other piece of evidence that you have used.

cation in **J** is

other piece of evidence is

.....
[2]

3 You are going to measure the acceleration of free fall g using a spring.

(a) Measure and record the unstretched length l_0 of the spring to the nearest millimetre.

Do **not** include the loops at the end of the spring in your measurement.

$l_0 = \dots\dots\dots$ mm [1]

(b) Attach the spring to the clamp as shown in Fig. 3.1.

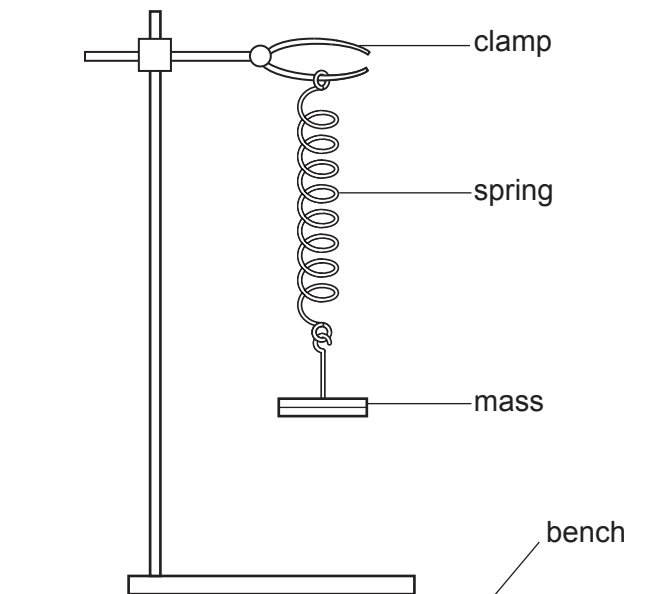

Fig. 3.1

Procedure

- Suspend a 200 g mass on the spring.
- Measure the stretched length l_1 of the spring.
- Record your value in Table 3.1 on page 8.
- Calculate the extension e of the spring produced by the mass. Use the equation shown.

$$e = l_1 - l_0$$

- Record your value in Table 3.1 on page 8. [1]

Table 3.1

mass m/g	stretched length l_1/mm	extension e/mm	time t taken for 20 oscillations /s	period T/s	T^2/s^2
200					
300					
400					
500					

- (c) Pull the mass down a **small** distance and release it. The mass oscillates up and down. The period T of the oscillations is the time taken for **one** oscillation.

One oscillation is one complete up-motion and one complete down-motion of the mass, as shown in Fig. 3.2.

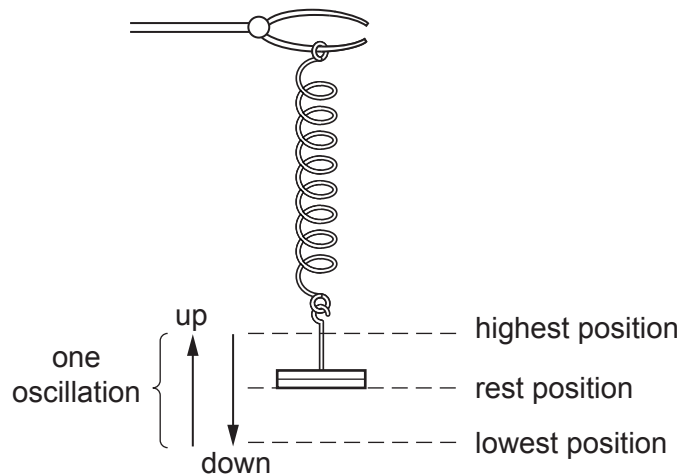

Fig. 3.2

- (i) Measure the time t taken for 20 oscillations. Record this time in Table 3.1. [1]
- (ii) Repeat the procedure in (b) and the measurement in (c)(i) for masses of 300g, 400g and 500g. [1]
- (iii) Use your answers from (c)(i) and (c)(ii) to calculate the period T (the time for one oscillation) for each of the masses.

Record, in Table 3.1, your values of T .

[1]

- (iv) Calculate the values of T^2 . Record, in Table 3.1, your answers to **two** significant figures. [1]

- (d) (i) On the grid provided, plot a graph of T^2 (vertical axis) against e . Start your axes at (0,0).

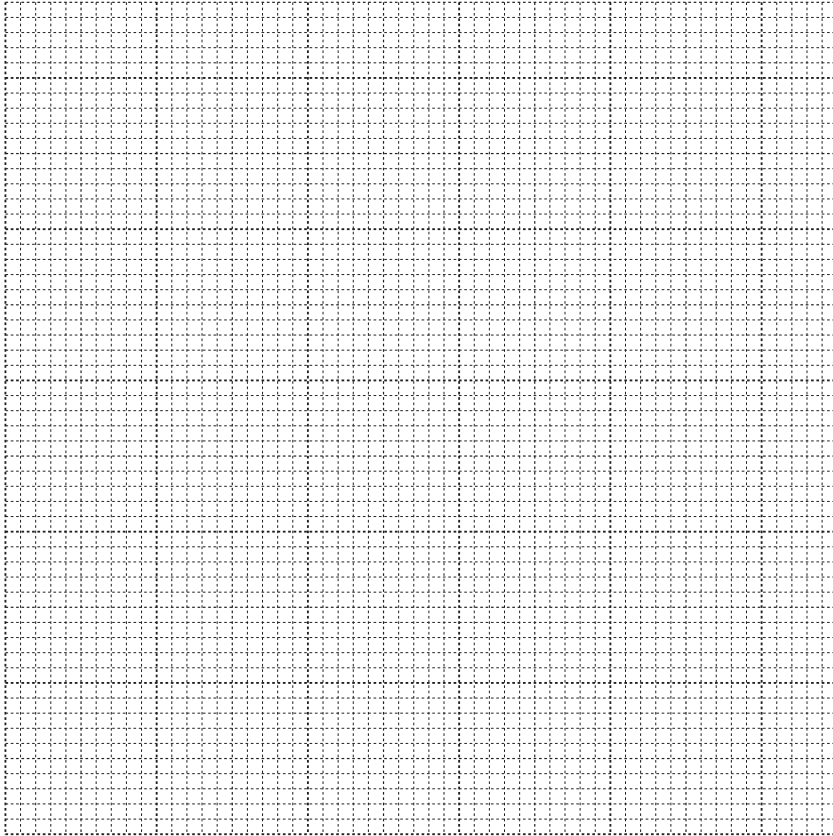

[3]

- (ii) Draw the best-fit straight line.

[1]

- (iii) Calculate the gradient of your line.

Show all working and indicate on your graph the values you chose to enable an accurate value of the gradient to be calculated.

gradient =[2]

- (iv) Use your answer to (d)(iii) and the equation shown, to determine a value for the acceleration of free fall g .

$$g = \frac{0.0395}{\text{gradient}}$$

$g = \dots\dots\dots \text{ m/s}^2$ [1]

(e) It is important to avoid line-of-sight (parallax) errors when measuring the length of the spring.

Describe how you avoided this error.

.....
.....
.....[1]

(f) The value of g at the Earth's surface is 9.8 m/s^2 .

State **and** explain whether your value in (d)(iv) agrees with this value to within the limits of experimental accuracy.

.....
.....[1]

NOTES FOR USE IN QUALITATIVE ANALYSIS

Tests for anions

<i>anion</i>	<i>test</i>	<i>test result</i>
carbonate (CO_3^{2-})	add dilute acid	effervescence, carbon dioxide produced
chloride (Cl^-) [in solution]	acidify with dilute nitric acid, then add aqueous silver nitrate	white ppt.
nitrate (NO_3^-) [in solution]	add aqueous sodium hydroxide, then aluminium foil; warm carefully	ammonia produced
sulfate (SO_4^{2-}) [in solution]	acidify with dilute nitric acid, then add aqueous barium nitrate	white ppt.

Tests for aqueous cations

<i>cation</i>	<i>effect of aqueous sodium hydroxide</i>	<i>effect of aqueous ammonia</i>
ammonium (NH_4^+)	ammonia produced on warming	–
copper(II) (Cu^{2+})	light blue ppt., insoluble in excess	light blue ppt., soluble in excess, giving a dark blue solution
iron(II) (Fe^{2+})	green ppt., insoluble in excess	green ppt., insoluble in excess
iron(III) (Fe^{3+})	red-brown ppt., insoluble in excess	red-brown ppt., insoluble in excess
zinc (Zn^{2+})	white ppt., soluble in excess, giving a colourless solution	white ppt., soluble in excess, giving a colourless solution

Tests for gases

<i>gas</i>	<i>test and test result</i>
ammonia (NH_3)	turns damp red litmus paper blue
carbon dioxide (CO_2)	turns limewater milky
chlorine (Cl_2)	bleaches damp litmus paper
hydrogen (H_2)	'pops' with a lighted splint
oxygen (O_2)	relights a glowing splint

Permission to reproduce items where third-party owned material protected by copyright is included has been sought and cleared where possible. Every reasonable effort has been made by the publisher (UCLES) to trace copyright holders, but if any items requiring clearance have unwittingly been included, the publisher will be pleased to make amends at the earliest possible opportunity.

To avoid the issue of disclosure of answer-related information to candidates, all copyright acknowledgements are reproduced online in the Cambridge International Examinations Copyright Acknowledgements Booklet. This is produced for each series of examinations and is freely available to download at www.cie.org.uk after the live examination series.

Cambridge International Examinations is part of the Cambridge Assessment Group. Cambridge Assessment is the brand name of University of Cambridge Local Examinations Syndicate (UCLES), which is itself a department of the University of Cambridge.