



**Surname** \_\_\_\_\_

**Other Names** \_\_\_\_\_

**Centre Number** \_\_\_\_\_

**Candidate Number** \_\_\_\_\_

**Candidate Signature** \_\_\_\_\_

**AS**

**PHYSICS**

**Paper 1**

**7407/1**

**Tuesday 15 May 2018      Morning**

**Time allowed: 1 hour 30 minutes**

**At the top of the page, write your surname and other names, your centre number, your candidate number and add your signature.**

**[Turn over]**



**For this paper you must have:**

- **a pencil and a ruler**
- **a scientific calculator**
- **a Data and Formulae Booklet.**

## **INSTRUCTIONS**

- **Use black ink or black ball-point pen.**
- **Answer ALL questions.**
- **You must answer the questions in the spaces provided. Do not write on blank pages.**
- **Do all rough work in this book. Cross through any work you do not want to be marked.**
- **Show all your working.**



## **INFORMATION**

- **The marks for questions are shown in brackets.**
- **The maximum mark for this paper is 70.**
- **You are expected to use a scientific calculator where appropriate.**
- **A Data and Formulae Booklet is provided as a loose insert.**

**DO NOT TURN OVER UNTIL TOLD TO DO SO**

**Answer ALL questions.**

**0 | 1 | . | 1** Describe the interaction that is responsible for keeping protons and neutrons together in a stable nucleus.

**You should include details of the properties of the interaction in your answer. [3 marks]**

---

---

---

---

---

---

---

---

---

---

---

---

---

---

---

---

---

---

---

---

---

---

---

**0 1 . 2** Nuclei can decay by alpha decay and by beta decay.

**In alpha decay only one particle is emitted but in beta decay there are two emitted particles.**

**Explain how baryon number is conserved in alpha and beta decay. [3 marks]**

---

---

---

---

---

---

---

---

---

---

---

---

**[Turn over]**



**0 1 . 3** Kaons are mesons that can be produced by the strong interaction between pions and protons.

The equation shows a reaction in which a kaon and a lambda particle are produced.

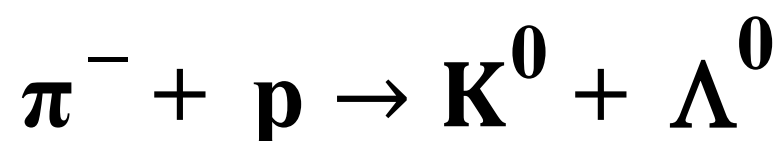

Deduce the quark structure of the  $\Lambda^{0}$   
[2 marks]

quark structure = \_\_\_\_\_

**0 1 . 4** The kaon decays by the weak interaction.

The equation shows an example of kaon decay.

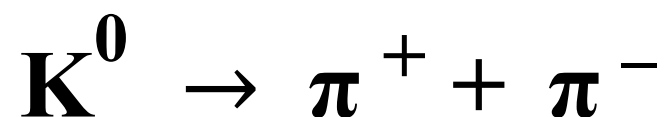

State ONE feature of this decay that shows it is an example of the weak interaction. [1 mark]

---

---

---

**[Turn over]**

**BLANK PAGE**





**0 1 . 5**

**There have been considerable advances in our understanding of particle physics over the past 100 years.**

**Explain why it is necessary for many teams of scientists and engineers to collaborate in order for these advances to be made. [2 marks]**

---

---

---

---

---

---

---

---

---

---

<b>11</b>

**[Turn over]**



**0 2 . 1** **FIGURE 1** shows a truck moving freely down a ramp inclined at an angle to the horizontal.

**FIGURE 1**

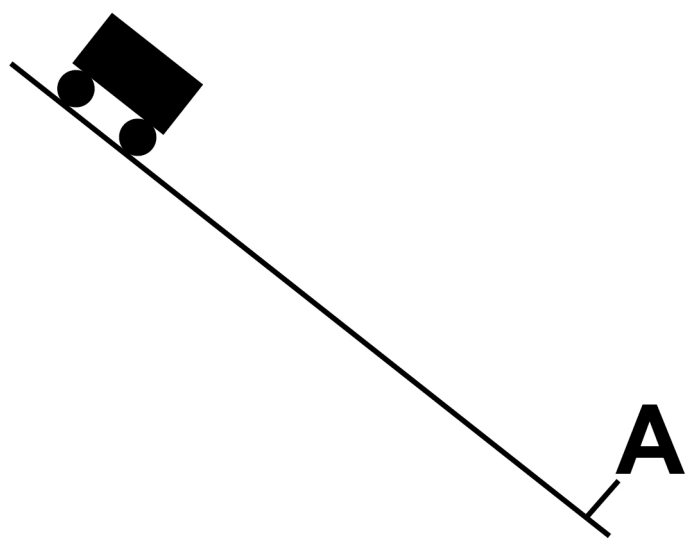

**The truck starts from rest at the top of the ramp and reaches point A. Friction and air resistance are negligible.**

**As the truck moves down the ramp to point A, its centre of mass has a total vertical displacement of 8.0 m**

11

**Calculate the speed of the truck  
at point A. [2 marks]**

**speed = \_\_\_\_\_ m s<sup>-1</sup>**

**[Turn over]**



**0 2 . 2** FIGURE 2 shows the truck moving down a ramp with a varying slope.

**FIGURE 2**

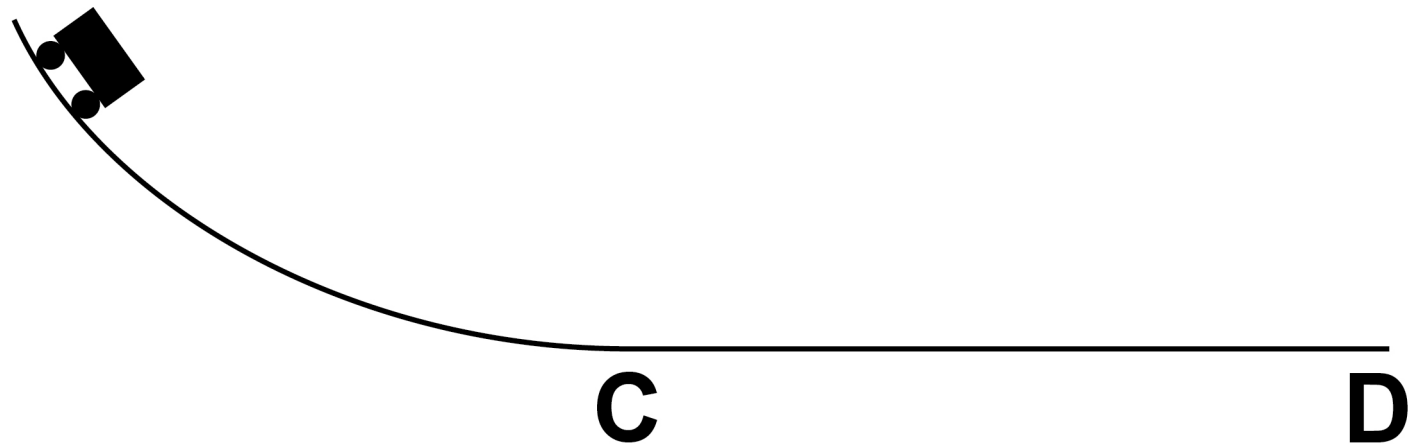

**The truck starts from rest and moves freely down the ramp. It reaches point C and then moves along the horizontal runway to D. Friction and air resistance are negligible.**

**13**

**Discuss how the acceleration of the truck in FIGURE 2 differs from the acceleration of the truck in FIGURE 1. [3 marks]**

---

---

---

---

---

---

---

---

---

---

---

---

---

---

---

---

---

---

---

---

---

---

---

**[Turn over]**



**0 2 . 3** The total vertical displacement of the centre of mass of the truck in FIGURE 2 is also 8.0 m

The speed of the truck when it reaches the horizontal runway is the same as the speed of the truck in FIGURE 1 when it reaches point A.

**Explain why. [1 mark]**

---

---

---

---

---

---

---

**[Turn over]**

**0 2 . 4** The horizontal runway in FIGURE 2, on page 12, has negligible friction and air resistance. As the truck moves along the runway, it starts to rain. The rain falls vertically and water collects in the truck.

**Discuss whether there are any changes in the momentum of the truck and collected water.**  
**[3 marks]**

---

---

---

---

---

---

---

---

---

---





03

**FIGURE 3** shows some of the energy levels for a hydrogen atom.

The diagram is not drawn to scale.

**FIGURE 3**

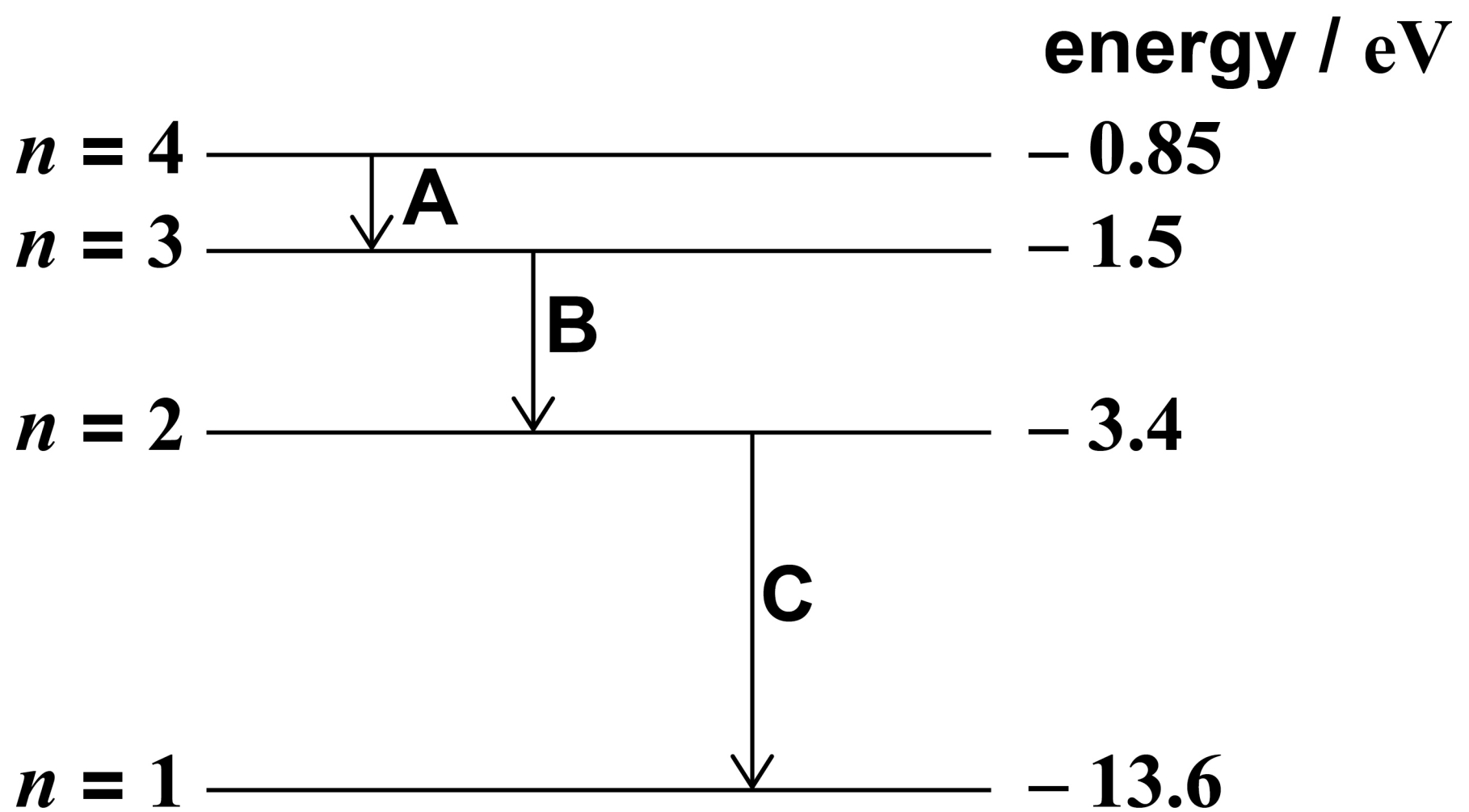

An excited hydrogen atom can emit photons of certain discrete frequencies. Three possible transitions are shown in **FIGURE 3**.

**03.1** The transitions shown in **FIGURE 3** result in photons being emitted in the ultraviolet, visible and infrared regions of the electromagnetic spectrum.

To which region of the spectrum do the emitted photons belong?

Tick (✓) the correct box for each transition, A, B and C.

[1 mark]

Transition	Ultraviolet	Visible	Infrared
A	<input type="checkbox"/>	<input type="checkbox"/>	<input type="checkbox"/>
B	<input type="checkbox"/>	<input type="checkbox"/>	<input type="checkbox"/>
C	<input type="checkbox"/>	<input type="checkbox"/>	<input type="checkbox"/>

[Turn over]



**03.2** Two ways to excite a hydrogen atom are by collision with a free electron or by the absorption of a photon.

**Explain why, for a particular transition, the photon must have an exact amount of energy whereas the free electron only needs a minimum amount of kinetic energy. [3 marks]**

---

---

---

---

---

---

---

---

---

---



**0 3 . 3** The surface of a sample of caesium is exposed to photons emitted in each of the three transitions shown in FIGURE 3 on page 18.

The threshold frequency of caesium is  $5.1 \times 10^{14}$  Hz

Determine whether any of these transitions would produce photons that would cause electrons to be emitted from the surface of caesium. [3 marks]

---

---

---

---

---

---

---

**[Turn over]**



**BLANK PAGE**





**0 3 . 4** Photons each with energy 12.1 eV are incident on the surface of the caesium sample.

**Calculate the maximum speed of electrons emitted from the caesium. [3 marks]**

**maximum speed = \_\_\_\_\_ m s<sup>-1</sup>**

**[Turn over]**

<b>10</b>



04

FIGURE 4 shows a uniform beam supported by two light cables, AB and AC, which are attached to a single steel cable from a crane. The beam is stationary and in equilibrium.

FIGURE 4

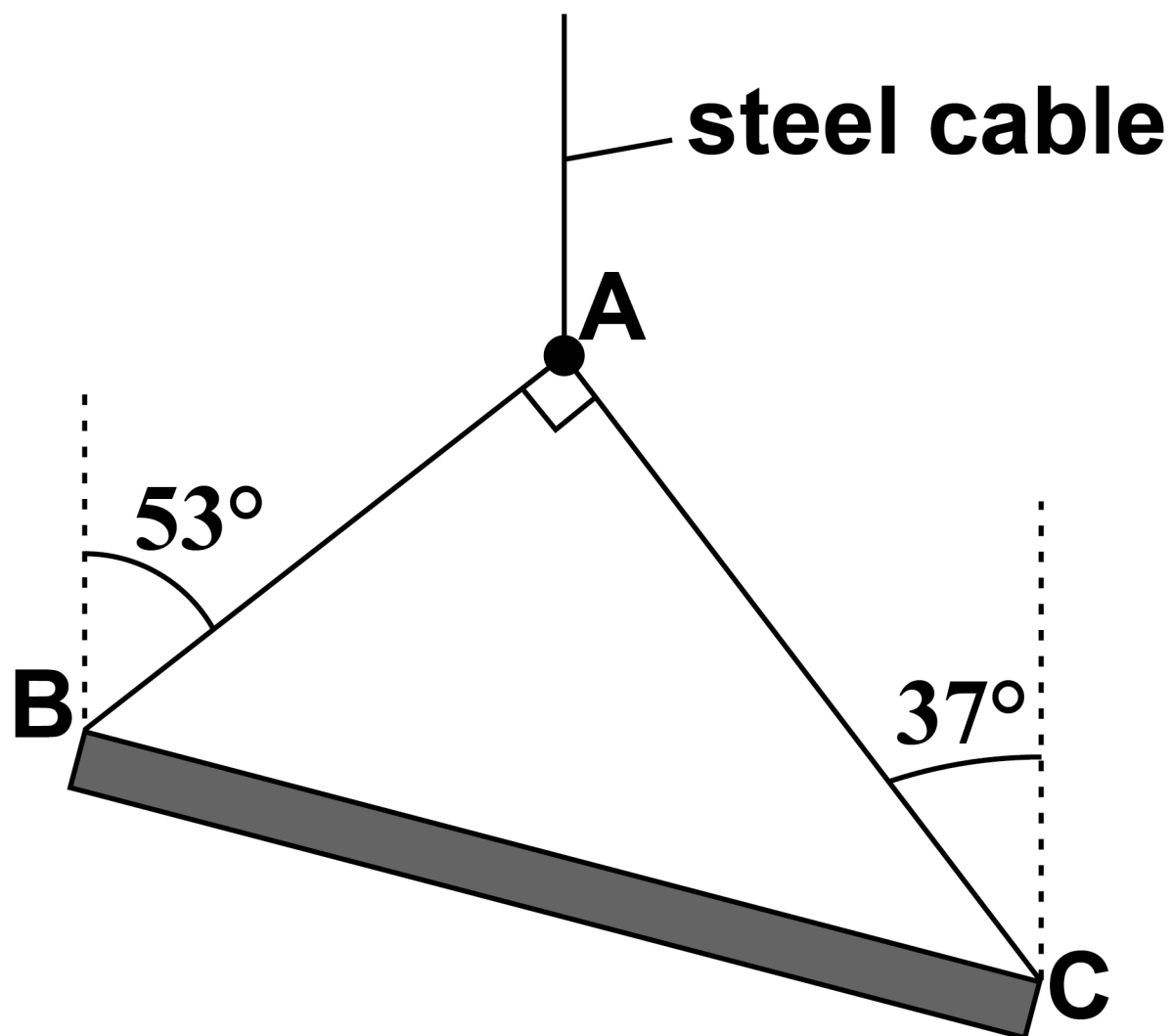

**0 4 . 1**

**State TWO necessary conditions for the beam to be in equilibrium. [2 marks]**

**Condition 1** \_\_\_\_\_

---

---

---

---

---

**Condition 2** \_\_\_\_\_

---

---

---

---

**[Turn over]**

**0 4 . 2** State what is meant by the centre of mass. [1 mark]

---

---

---

**0 4 . 3** Explain why the centre of mass of the beam in FIGURE 4, on page 26, must be vertically below A. [2 marks]

---

---

---

---

---

---

---

**0 4 . 4** The weight of the beam is  
12 000 N

**Calculate the tension  $T_1$  in cable  
AB and the tension  $T_2$  in cable  
AC. [4 marks]**

$$T_1 = \underline{\hspace{15em}} \text{ N}$$

$$T_2 = \underline{\hspace{15em}} \text{ N}$$

**[Turn over]**



**0 4 . 5** The steel cable from the crane has a circular cross-section of diameter  $1.5 \times 10^{-2}$  m. The cable is 12 m long.

Calculate the extension of the cable caused by the weight of the beam. You can assume that the weights of **ALL CABLES** are negligible.

Young modulus of steel =  $2.0 \times 10^{11}$  Pa [3 marks]

extension = \_\_\_\_\_ m

12



**0 5 . 1** Calculate the weight of an ice cube that has volume  $4.0 \times 10^{-6} \text{ m}^3$

density of ice =  $920 \text{ kg m}^{-3}$   
[2 marks]

weight = \_\_\_\_\_ N

[Turn over]



**0 5 . 2** **FIGURE 5** shows the ice cube floating in a beaker of water.

**FIGURE 5**

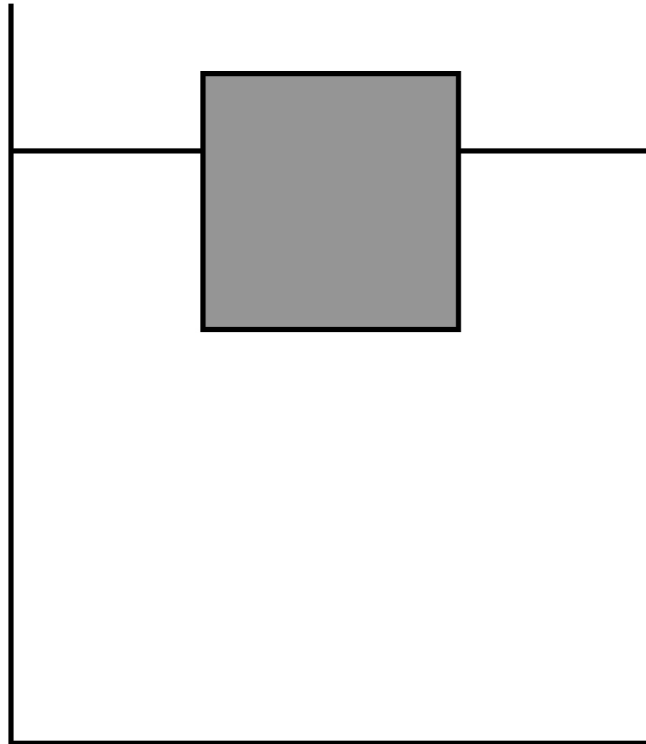

**When the ice cube is placed in the beaker, it displaces a volume of water causing the water level to rise.**

**The weight of water displaced is equal to the weight of the ice cube.**



**33**

**Calculate the volume of water displaced by the ice cube. [1 mark]**

**density of water =  $1000 \text{ kg m}^{-3}$**

**volume = \_\_\_\_\_  $\text{m}^3$**

**[Turn over]**



**05.3**

The ice cube in FIGURE 5, on page 32, is replaced by another cube also with volume

$$4.0 \times 10^{-6} \text{ m}^3$$

This cube is made of ice containing a small piece of iron. The mass of water now displaced is  $3.9 \times 10^{-3} \text{ kg}$

Calculate the volume of the piece of iron.

density of iron =  $7800 \text{ kg m}^{-3}$   
[3 marks]

volume = \_\_\_\_\_  $\text{m}^3$

6

0	6
---	---

A student connects four lamps A, B, C and D in the circuit shown in FIGURE 6. The battery has an emf of  $9.0\text{ V}$  and negligible internal resistance.

**FIGURE 6**

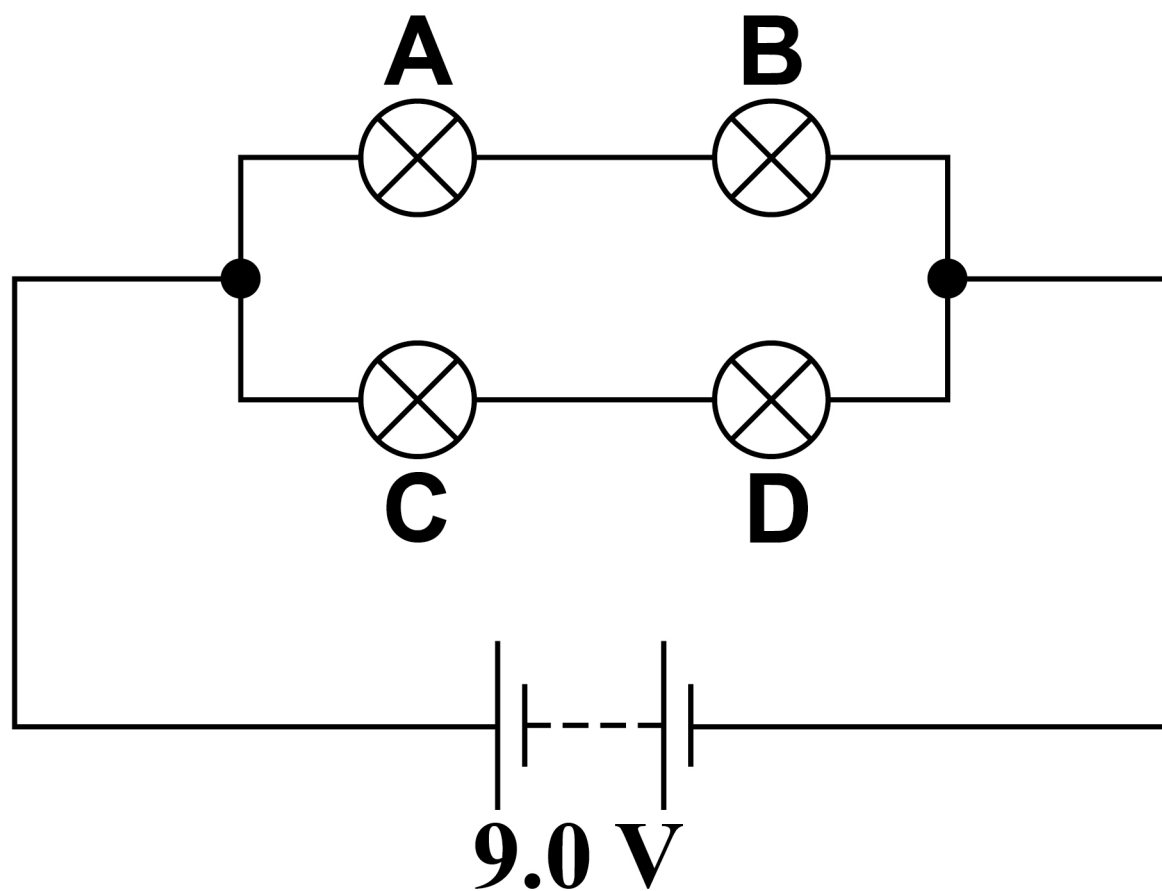

**[Turn over]**

**06.1** TABLE 1 shows the operating conditions for the lamps when they are at normal brightness.

**TABLE 1**

<b>Lamps</b>	<b>Operating voltage / V</b>	<b>Power / W</b>
<b>A and C</b>	<b>6.0</b>	<b>6.0</b>
<b>B and D</b>	<b>3.5</b>	<b>4.1</b>

**The student observes that TWO of the lamps are at their normal brightness.**

**Assume that any changes in resistance of the lamps are negligible.**

**Determine which TWO lamps are at their normal brightness.**

**Use calculations to support your answer. [4 marks]**

---

---

---

**[Turn over]**



- 06.2** The student connects another lamp E in the circuit as shown in **FIGURE 7**.  
Lamp E is identical to lamps A and C.

**FIGURE 7**

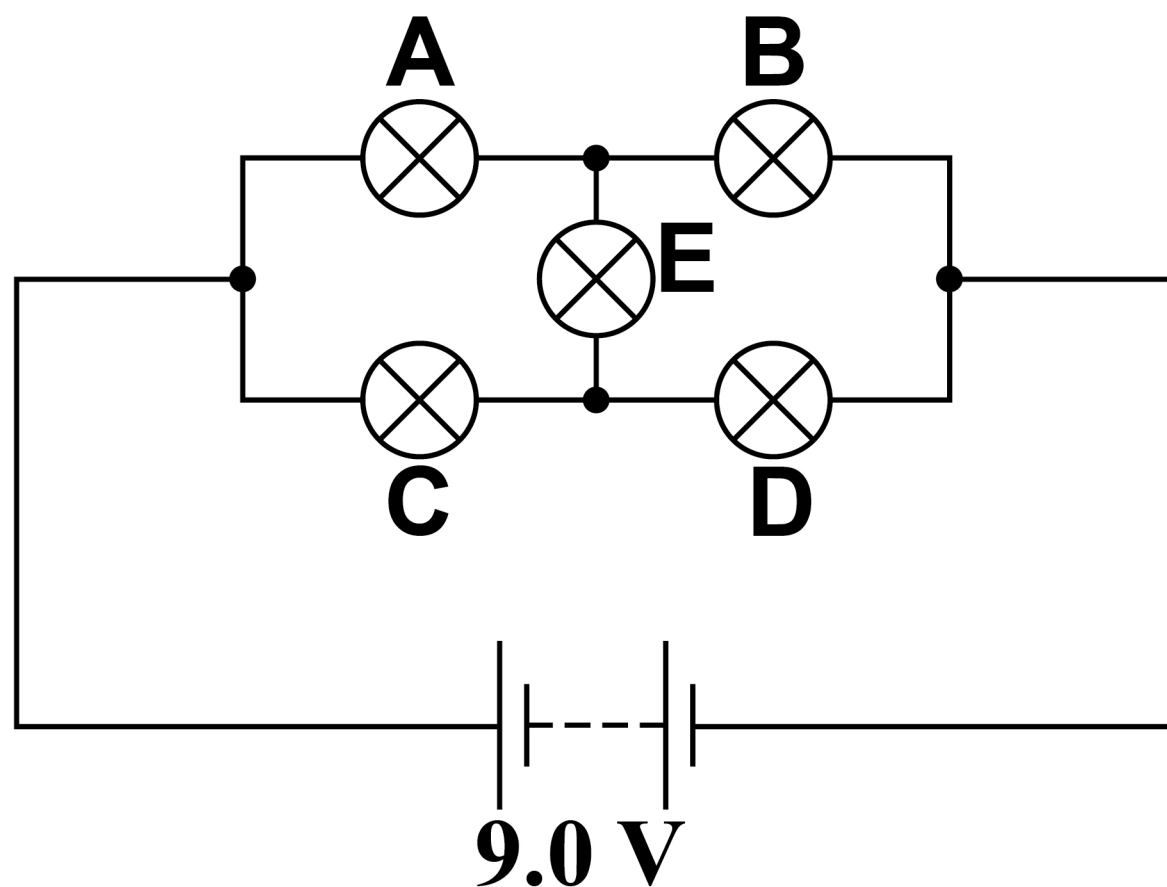

**Explain what the student would observe regarding the brightness of the lamps.**

**Refer to potential differences across lamp E in your answer.**  
**[3 marks]**







---

---

---

---

---

---

**[Turn over]**

<b>10</b>



07

**FIGURE 8** shows a diagram of apparatus used to demonstrate the formation of interference fringes using a white light source in a darkened room. Light from the source passes through a single slit and then through two narrow slits  $S_1$  and  $S_2$ .

The diagram is not drawn to scale.

**FIGURE 8**

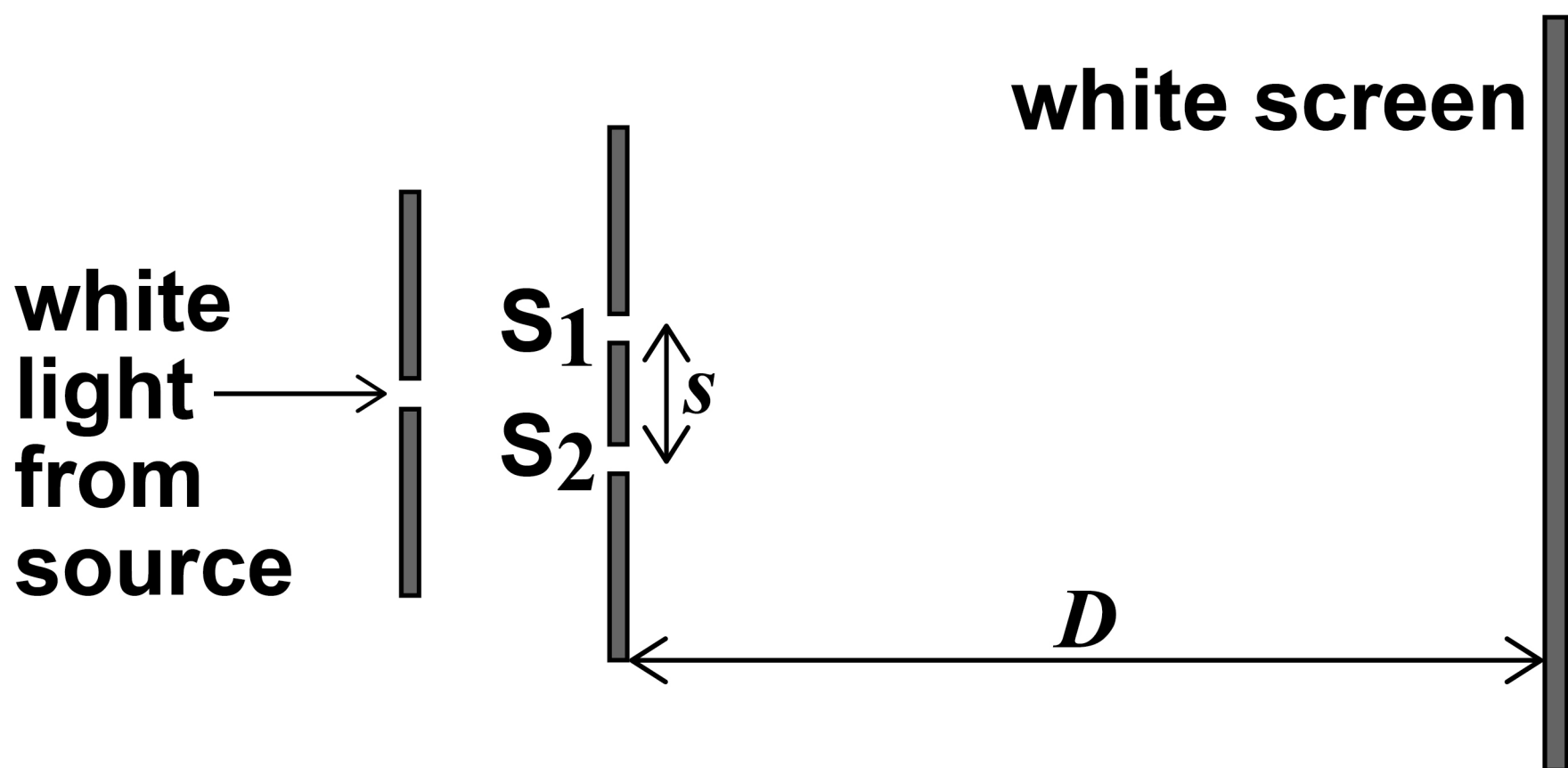



**07.2** A filter transmits only green light of wavelength  $\lambda$  and red light of wavelength  $1.2\lambda$ . This filter is placed between the light source and the single slit.

**Describe the interference pattern now seen on the white screen.**

**Use a calculation to support your answer. [4 marks]**



**07.3**

**A student decides to use the apparatus shown in FIGURE 8, on page 42, to determine the wavelength of red light using a filter that transmits only red light.**

**The student suggests the following changes:**

- decrease slit separation  $s$**
- decrease  $D$ , the distance between the slits and the screen.**

**The student decides to make each change independently.**

**Discuss the effects each independent change has on the interference pattern, and whether this change is likely to reduce uncertainty in the determination of the wavelength. [6 marks]**













**There are no questions printed on this page.**

For Examiner's Use	
Question	Mark
1	
2	
3	
4	
5	
6	
7	
<b>TOTAL</b>	

### Copyright information

For confidentiality purposes, from the November 2015 examination series, acknowledgements of third party copyright material will be published in a separate booklet rather than including them on the examination paper or support materials. This booklet is published after each examination series and is available for free download from [www.aqa.org.uk](http://www.aqa.org.uk) after the live examination series.

Permission to reproduce all copyright material has been applied for. In some cases, efforts to contact copyright-holders may have been unsuccessful and AQA will be happy to rectify any omissions of acknowledgements. If you have any queries please contact the Copyright Team, AQA, Stag Hill House, Guildford, GU2 7XJ.

Copyright © 2018 AQA and its licensors. All rights reserved.

**IB/M/Jun18/LO/7407/1/E3**

