

Answer Sheets

SECTION 1

- 1 A B C D E
- 2 A B C D E
- 3 A B C D E
- 4 A B C D E
- 5 A B C D E

- 6 A B C D E
- 7 A B C D E
- 8 A B C D E
- 9 A B C D E
- 10 A B C D E

- 11 A B C D E
- 12 A B C D E
- 13 A B C D E
- 14 A B C D E
- 15 A B C D E

- 16 A B C D E
- 17 A B C D E
- 18 A B C D E
- 19 A B C D E
- 20 A B C D E

SECTION 2

- 1 A B C D E
- 2 A B C D E
- 3 A B C D E
- 4 A B C D E
- 5 A B C D E
- 6 A B C D E

- 7 A B C D E
- 8 A B C D E
- 9 A B C D E
- 10 A B C D E
- 11 A B C D E

- 12 A B C D E
- 13 A B C D E
- 14 A B C D E
- 15 A B C D E
- 16 A B C D E

- 17 A B C D E
- 18 A B C D E
- 19 A B C D E
- 20 A B C D E
- 21 A B C D E

SECTION 3

- 1 A B C D E
- 2 A B C D E
- 3 A B C D E
- 4 A B C D E
- 5 A B C D E
- 6 A B C D E
- 7 A B C D E
- 8 A B C D E

- 9 A B C D E
- 10 A B C D E
- 11 A B C D E
- 12 A B C D E
- 13 A B C D E
- 14 A B C D E
- 15 A B C D E
- 16 A B C D E

- 17 A B C D E
- 18 A B C D E
- 19 A B C D E
- 20 A B C D E
- 21 A B C D E
- 22 A B C D E
- 23 A B C D E

- 24 A B C D E
- 25 A B C D E
- 26 A B C D E
- 27 A B C D E
- 28 A B C D E
- 29 A B C D E
- 30 A B C D E

SECTION 4

- 1 A B C D E
- 2 A B C D E
- 3 A B C D E
- 4 A B C D E
- 5 A B C D E
- 6 A B C D E
- 7 A B C D E

- 8 A B C D E
- 9 A B C D E
- 10 A B C D E
- 11 A B C D E
- 12 A B C D E
- 13 A B C D E
- 14 A B C D E

- 15 A B C D E
- 16 A B C D E
- 17 A B C D E
- 18 A B C D E
- 19 A B C D E
- 20 A B C D E
- 21 A B C D E

- 22 A B C D E
- 23 A B C D E
- 24 A B C D E
- 25 A B C D E
- 26 A B C D E
- 27 A B C D E

SECTION 5

- 1 A B C D E
- 2 A B C D E
- 3 A B C D E
- 4 A B C D E
- 5 A B C D E
- 6 A B C D E

- 7 A B C D E
- 8 A B C D E
- 9 A B C D E
- 10 A B C D E
- 11 A B C D E

- 12 A B C D E
- 13 A B C D E
- 14 A B C D E
- 15 A B C D E
- 16 A B C D E

- 17 A B C D E
- 18 A B C D E
- 19 A B C D E
- 20 A B C D E
- 21 A B C D E

Answer Sheets

SECTION

6

- 1 (A) (B) (C) (D) (E)
2 (A) (B) (C) (D) (E)
3 (A) (B) (C) (D) (E)
4 (A) (B) (C) (D) (E)

- 5 (A) (B) (C) (D) (E)
6 (A) (B) (C) (D) (E)
7 (A) (B) (C) (D) (E)
8 (A) (B) (C) (D) (E)

- 9 (A) (B) (C) (D) (E)
10 (A) (B) (C) (D) (E)
11 (A) (B) (C) (D) (E)
12 (A) (B) (C) (D) (E)

- 13 (A) (B) (C) (D) (E)
14 (A) (B) (C) (D) (E)
15 (A) (B) (C) (D) (E)
16 (A) (B) (C) (D) (E)





SECTION





7



For Questions 1–13:

Only answers entered in the ovals in each grid area will be scored.

You will not receive credit for anything written in the boxes above the ovals.

1  2  3  4  5 

6  7  8  9  10 

11  12  13 

Practice Test

2

Section 1

20 Questions ■ Time—25 Minutes

Directions: Read each of the passages carefully, then answer the questions that come after them. The answer to each question may be stated overtly or only implied. You will not have to use outside knowledge to answer the questions—all the material you will need will be in the passage itself. In some cases, you will be asked to read two related passages and answer questions about their relationship to one another. Mark the letter of your choice on your answer sheet.

A bill is the form used for most legislation in the United State Congress. Only constitutional amendments and procedural issues affecting the House and Senate are adopted by a resolution, rather than a bill. Bills can be written to be permanent or temporary, general or special. A bill originating in the House of Representatives is designated by the letters “H.R.,” signifying “House of Representatives,” followed by a number that it retains throughout all its parliamentary stages. The number on the bill is determined by the order in which it was submitted during a particular session. Bills are presented to the President for action when approved in identical form by both the House of Representatives and the Senate.

1. From the passage, it can be inferred that a bill that is designated as H.R. 1 is the first bill
 - (A) voted upon by the House of Representatives in a particular session of Congress.
 - (B) submitted to the House of Representatives in a particular session of Congress.
 - (C) sent to the Senate from the House of Representatives in a particular session of Congress.
 - (D) originating in the House of Representatives signed by the President in a particular session of Congress.
 - (E) debated on the floor of the House of Representatives in a particular session of Congress.

2. It is implied in the passage that once a bill is passed in the House of Representatives that it might be sent to which of the following two places?

- (A) Senate, conference committee
- (B) Senate, House committee
- (C) Senate, President
- (D) President, Supreme Court
- (E) President, Congress

Native American views of nature have important parallels in contemporary ecology. Through traditional customs and symbols like the medicine wheel, a circular arrangement of stones often interpreted as representing the relationship between Earth, air, water, and fire, Native Americans have long recognized and celebrated the connectedness among all natural things. Indeed, the Native American view of the world has always been consistent with that of Earth ecology—that Earth is a single system of interconnected parts.

3. The symbol of the medicine wheel is given as a(n)

- (A) illustration of how Native Americans view the Earth as an interconnected system.
- (B) example of the Native American understanding of the four elements.
- (C) example of the interrelatedness of the four basic elements.
- (D) critique of contemporary ecological understandings of the Earth.
- (E) contrast to contemporary ecological understandings of the Earth.

4. Given what the passage states about Native American views of nature, which of the following scenarios most accords with a Native American view?

- (A) Studying a microorganism removed from its habitat.
- (B) Studying Earth through satellite images.
- (C) Studying only animals and substances with spiritual symbolism.
- (D) Studying a specific organism's interrelationships with its habitat.
- (E) Studying a habitat as a whole.

Questions 5–12 are based on the following passage.

This passage is about Aaron Copland, one of the most celebrated American composers.

Line Copland's music of the late 1920s
culminates in two key works, both
uncompromising in their modernism: the
Symphonic Ode of 1929 and the *Piano*
(5) *Variations* of 1930. The fate of these
compositions contrasts sharply. While the
Piano Variations is not often performed
in concert, it is well known to pianists
because, although it does contain
(10) virtuoso passages, even those of very
modest ability can "play at" the work in
private. It represents the twentieth-
century continuation of the great
tradition of keyboard variations—the
(15) tradition that produced such works as
the Bach *Goldberg Variations*, and
Beethoven's *Diabelli Variations*. Cop-
land's *Symphonic Ode*, on the other
hand, remains almost unknown: An
(20) intense symphonic movement, it was
considered unperformable by the
conductor Serge Koussevitzky, otherwise
the most potent American champion of

(25) Copland's work during the first half of the century. Koussevitzky did perform a revised version in 1932; but even with a second, more extensive revision in 1955, the *Ode* is seldom played. It is Copland's single longest orchestral movement.

(30) Perhaps as a reaction to the performance problems of the *Symphonic Ode*, Copland's next two orchestral works deal in shorter units of time: the *Short Symphony* of 1933 requires fifteen
(35) minutes for three movements and the six *Statements* for orchestra of 1935 last only nineteen minutes. Yet, in fact, these works were more complex than the *Ode*; in particular, the wiry, agile rhythms of
(40) the opening movement of the *Short Symphony* proved too much for both the conductors Serge Koussevitzky and Leopold Stokowski. In the end it was Carlos Chávez and the Orquesta Sinfónica de México who gave the *Short Symphony* its premiere.
(45)

It may have been partly Copland's friendship with Carlos Chávez that drew him to Mexico. Copland first visited
(50) Mexico in 1932 and returned frequently in later years. His initial delight in the country is related in his letter of January 13, 1933, to Mary Lescaze, in which he glowingly describes the Mexican people and the Mexican landscape. His interest
(55) in Mexico is also reflected in his music, including *El Salón México* (1936) and the *Three Latin American Sketches* (1972).

(60) Mexico was not Copland's only Latin American interest. A 1941 trip to Havana suggested his *Danzón Cubano*. By the early 1940s he was friends with South American composers such as
(65) Jacobo Ficher, and in 1947 he toured South America for the State Department.

(Some of the folk music he heard in Rio de Janeiro on this trip appears in his later works.) Copland in fact envisioned
(70) "American music" as being music of the Americas as a whole. His own use of Mexican material in the mid-1930s helped make his style more accessible to listeners not willing to accept the
(75) challenges of modern symphonic music.

5. What is the author's tone toward Copland's music?
- (A) Strident skepticism
 - (B) Clinical objectivity
 - (C) Respectful description
 - (D) Qualified enthusiasm
 - (E) Unqualified praise
6. The word "virtuoso" in line 10 could best be replaced with
- (A) ostentatious.
 - (B) intricate
 - (C) raucous.
 - (D) abstruse.
 - (E) publicized.

7. In the first paragraph the author states that *Symphonic Ode* and *Piano Variations* had different fates in that
- (A) one was largely ignored while the other was almost universally praised.
 - (B) one, a simpler piece, won popular acclaim, while the other, a more complex piece, won critical acclaim.
 - (C) one, a simpler piece, became widely known by pianists, but the other, a more complex piece, remained largely unknown.
 - (D) one, featuring Mexican influences, was popular in Latin America, and the other, a modernist piece, was popular in the United States.
 - (E) both were initially acclaimed but only one became part of Copland's corpus of beloved works.
8. Koussevitzky is mentioned as an example of a(n)
- (A) American conductor who admired Copland's work, but nonetheless found some pieces too difficult to perform.
 - (B) friend of Copland's who agreed to perform his less popular works.
 - (C) European composer who took issue with the difficulty of Copland's early work.
 - (D) musician who appreciated Copland's work but was unable to play it.
 - (E) European conductor who performed Copland's work.
9. The author of the passage believes that Copland's works immediately subsequent to the *Symphonic Ode* were possibly written
- (A) for Copland's new relationship with Carlos Chávez and the Orquesta Sinfónica de México.
 - (B) to be simpler than the *Symphonic Ode*, on account of its difficulty in being performed.
 - (C) to be shorter than the *Symphonic Ode*, because the *Ode* was not being performed.
 - (D) to demand even more of conductors and musicians attempting to play Copland's music.
 - (E) to reflect Copland's new interest in Latin America.
10. In the sentence beginning "Yet, in fact, these works. . ." in lines 37–43 [second paragraph], the author suggests that
- (A) parts of the *Short Symphony* simply weren't melodic enough to engage audiences.
 - (B) the *Statements* were too brief to warrant a formal performance.
 - (C) even those who admired Copland's work lost patience with the *Short Symphony* and *Statements*.
 - (D) the *Statements* and *Short Symphony* determined which performers were truly excellent and which were mediocre.
 - (E) the *Short Symphony* had melodies that were too quick to be played even by famous musicians.

11. The author suggests that Copland believed Latin American music

- (A) was unfamiliar enough to a North American audience that he needed to introduce them to it.
- (B) was different enough from North American music that incorporating aspects of it would make his music unique and exciting.
- (C) influenced and was influenced by North American music.
- (D) primarily originated in Mexico and Cuba.
- (E) embodied the polar opposite of modernist aesthetics.

12. The sentence beginning “His own use of Mexican material. . .” in lines 71–75 suggests that the modernist music which also influenced Copland’s compositions was

- (A) superior in quality to his Latin American influences.
- (B) dry and passionless.
- (C) technically more challenging to perform.
- (D) inaccessible but rewarding.
- (E) outmoded by the 1930s.

Questions 13–20 are based on the following passage.

The following passage was written by Ed Lu, an astronaut, while a crew member of the International Space Station.

Line Whenever I get a chance, I spend time
just observing the planet below. It turns
out you can see a lot more from up here
than you might expect. First off, we
(5) aren’t as far away as some people
think—our orbit is only about 240 miles
above the surface of the Earth. While this
is high enough to see that the Earth is

(10) round, we are still just barely skimming
the surface when you consider that the
diameter of the Earth is over 8,000 miles.

So how much of the Earth can we see
at one time? When you are standing on
the ground, the horizon is a few miles
(15) away. When in a tall building, the
horizon can be as far as about 40 miles.
From the International Space Station, the
distance to the horizon is over 1,000
miles. So from horizon to horizon, the
(20) section of the Earth you can see at any
one time is a patch about 2,000 miles
across, almost enough to see the entire
United States at once. It isn’t exactly
seeing the Earth like a big blue marble,
(25) it’s more like having your face up against
a big blue beach ball. When I look out a
window that faces straight down, it is
actually pretty hard to see the horizon—
you need to get your face very close to
(30) the window. So what you see out a
window like that is a moving patch of
ground (or water).

From the time a place on the ground
comes into view until it disappears over
the horizon is only a few minutes, since
we are traveling 300 miles per minute.
When looking out a sideward facing
window, you can see the horizon of the
Earth against the black background of
(40) space. The horizon is distinctly curved.
The edge of the Earth isn’t distinct but
rather is smeared out due to the atmo-
sphere. Here you can get a feel for how
relatively thin the atmosphere is com-
(45) pared to the Earth as a whole. I can see
that the width of the atmosphere on the
horizon is about 1 degree in angular size,
which is about the width of your index
finger held out at arms length. There
(50) really isn’t a sharp boundary to the
atmosphere, but it gets rapidly thinner

(55) the higher you go. Not many airplanes can fly higher than about 10 miles, and the highest mountains are only about 6 miles high. Above about 30 miles there is very little air to speak of, but at night you can see a faint glow from what little air there is at that height.

(60) Since we orbit at an altitude about 40 times higher than the tallest mountain, the surface of the Earth is pretty smooth from our perspective. A good way to imagine our view is to stand up and look down at your feet. Imagine that your eyes are where the International Space Station is orbiting, and the floor is the surface of the Earth. The atmosphere would be about 6 inches high, and the height of the tallest mountain is less than 2 inches, or about the height of the tops of your feet. Almost all of the people below you would live in the first one quarter of an inch from the floor. The horizon of the Earth is a little over 20 feet away from where you are standing. If you are standing on top of Denver, then about 15 feet to one side you can see San Francisco, and about 15 feet to the other side you can see Chicago.

13. The primary purpose of this passage is to
- (A) provide a layperson's account of the Space Station's motion over the Earth.
 - (B) explain the relationship between the diameter of the Earth and the thickness of the Earth's atmosphere.
 - (C) answer the imagined question, "What do astronauts see from space?"
 - (D) give a glimpse of some of the daily activities of astronauts in space.
 - (E) discuss the thickness and composition of the atmosphere.

14. The second half of the second paragraph is primarily concerned with
- (A) how one's location affects one's visual horizon.
 - (B) the thickness and density of the atmosphere.
 - (C) the speed of the International Space Station.
 - (D) the visual horizon from atop a tall building.
 - (E) being able to see all the Earth at once.
15. The author compares the view of the Earth from a downward-facing window in the International Space Station to
- (A) holding a blue marble at arm's length.
 - (B) having your face up-close to a big blue beach ball.
 - (C) looking at the tips of your shoes when standing up.
 - (D) looking at an object that is on the ground fifteen feet away when you are standing up.
 - (E) the view from a high-flying plane.
16. In the passage, the author contrasts the view from a window looking "straight down" with the view from
- (A) the observational deck.
 - (B) a sideward-facing window.
 - (C) a passenger airliner.
 - (D) a window looking "straight up."
 - (E) the circular windows on the space station.

17. The “faint glow” at night that the author speaks of in the passage comes from
- (A) low-lying atmosphere.
 - (B) the outer edges of the atmosphere.
 - (C) the eastern horizon of the Earth just before sunrise.
 - (D) haze from foreign particulates in the atmosphere.
 - (E) the sun reflecting off aircraft in the high atmosphere.
18. In the last paragraph the author provides the thought exercise with the reader’s height primarily to
- (A) demonstrate the distance from Denver to San Francisco.
 - (B) give the reader a concrete sense of the proportions involved in looking down from the space station.
 - (C) point out that most humans live at a low altitude relative to the height of the atmosphere.
 - (D) illustrate the expansion of one’s horizon at high altitudes.
 - (E) provide visual details of his activities in space.
19. The tone of the passage is best described as
- (A) fairly technical.
 - (B) highly professional.
 - (C) refreshingly irreverent.
 - (D) engagingly conversational.
 - (E) lyrically impassioned.
20. From the passage as a whole, it can be inferred that the astronauts’ training
- (A) did not prepare them for their free time in space.
 - (B) included a great deal of zero-gravity exercises.
 - (C) was more physical than technical.
 - (D) involved a strong background in math.
 - (E) focused on the astronauts’ communication procedures and abilities.

STOP

Do not proceed to the next section until time is up.

Section 2

21 Questions ■ Time—25 Minutes

Directions: Solve the following problems using any available space on the page for scratchwork. Mark the letter of your choice on the answer sheet that best corresponds to the correct answer.

Notes:

1. You may use a calculator. All of the numbers used are real numbers.
2. You may use the figures that accompany the problems to help you find the solution. Unless the instructions say that a figure is not drawn to scale, assume that it has been drawn accurately. Each figure lies in a plane unless the instructions say otherwise.

Reference Information

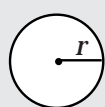

$$A = \pi r^2$$

$$C = 2\pi r$$



$$A = \ell w$$

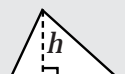

$$A = \frac{1}{2}bh$$

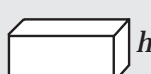

$$V = \ell wh$$



$$V = \pi r^2 h$$



$$c^2 = a^2 + b^2$$

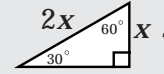

Special Right Triangles

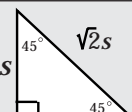

The number of degrees of arc in a circle is 360.

The measure in degrees of a straight angle is 180.

The sum of the measures in degrees of the angles of a triangle is 180.

1. If $x + 4y = 3$ and $x = -y$, then $y =$

- (A) -1
- (B) 0
- (C) 1
- (D) 2
- (E) 3

2. It takes Michael three hours to mow $2d$ acres. If Michael mows d acres at the same rate, how many minutes would it take?

- (A) 75
- (B) 90
- (C) 100
- (D) 120
- (E) 150

3. If $3f + 15 = 27$, then $3f - 6 =$

- (A) 6
- (B) 10
- (C) 12
- (D) 17
- (E) 20

4.

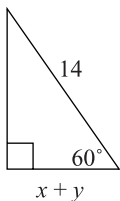

What is the value of $x + y$?

- (A) 7
- (B) $7\sqrt{2}$
- (C) $7\sqrt{3}$
- (D) 14
- (E) It cannot be determined.

5. Steve bought a snack and a drink for \$1.30. If the snack costs twenty cents less than the drink, how much does the drink cost?

- (A) \$0.50
- (B) \$0.55
- (C) \$0.65
- (D) \$0.75
- (E) \$0.80

6. If $f(x) = x + x^x$, when $x = 2$, $f(2x) =$

- (A) 6
- (B) 20
- (C) 200
- (D) 260
- (E) 4096

7. If $\sqrt{x^2} = 2x + 3$, then $x =$

- (A) $-x$
- (B) -3
- (C) x
- (D) -1
- (E) 4

8. If $|x + 1| > |y|$ then which of the following expresses the relationship between x and y ?

- (A) $x + 1 > y$
- (B) $x + 1 > y$
- (C) $x < y$
- (D) $x > y$
- (E) It cannot be determined.

9. 75% of 104 is the same value as 60% of what number?

- (A) 130
- (B) 133
- (C) 136
- (D) 140
- (E) 144

10. If $3y - x = 12$ is the equation of a line, what is twice the value of this line's y -intercept?

- (A) -2
- (B) 2
- (C) 4
- (D) 8
- (E) 24

11.

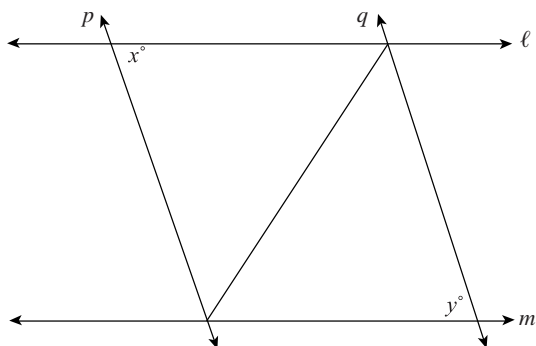

Given the figure above, which of the following must be a true statement?

- (A) $x > y$
- (B) $x < y$
- (C) $x = y$
- (D) $x + y = 90$
- (E) $x - y = 90$

Questions 12–14 refer to the following definition.

Let $\in m$ be defined for any positive integer m as the number obtained when the first and last digit of m switch places.

For example $\in 4 = 4$, $\in 35 = 53$, and $\in 2003 = 3002$.

12. $\in 2323 - \in 2321 =$

- (A) 2
- (B) 20
- (C) 200
- (D) 2000
- (E) 20,000

13. If A is a two-digit number between 10 and 20 and $(\in A)^2 = \in(A^2)$, then $A =$

- (A) 11
- (B) 13
- (C) 14
- (D) 16
- (E) 18

14. If $A > B > C > D > E$, and each is a digit 1 through 9, then $ABCD - \in(ABCD)$ is

- (A) less than zero.
- (B) between zero and 100.
- (C) between 100 and 500.
- (D) between 500 and 1000.
- (E) more than 1000.

15.

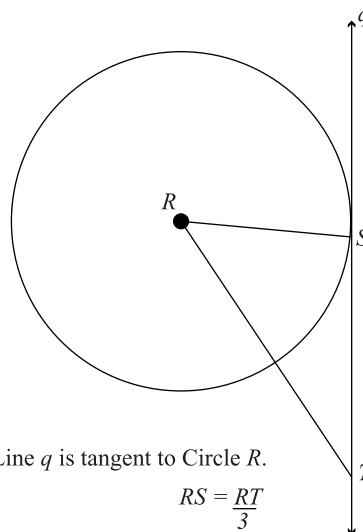

Line q is tangent to Circle R .

$$RS = \frac{RT}{3}$$

If $RT = 18$, what is the area of the above circle?

- (A) 6π
- (B) 12π
- (C) 36π
- (D) 81π
- (E) 324π

16. August and September Bassonet Sales

August Sales:	<input type="checkbox"/>	<input type="checkbox"/>	<input type="checkbox"/>	<input type="checkbox"/>
September Sales:	<input type="checkbox"/>	<input type="checkbox"/>	<input type="checkbox"/>	<input type="checkbox"/>

– 1,000 bassonets sold

– 50 bassonets sold and returned

Total Sales = -

According to the above table, which of the following statements is true?

- (A) September total sales are 3.5% greater than August total sales.
- (B) September total sales are 2.5% less than August total sales.
- (C) September total sales are 2.5% greater than August total sales.
- (D) September total sales are 5.4% less than August total sales.
- (E) September total sales are 5.4% greater than August total sales.

17.

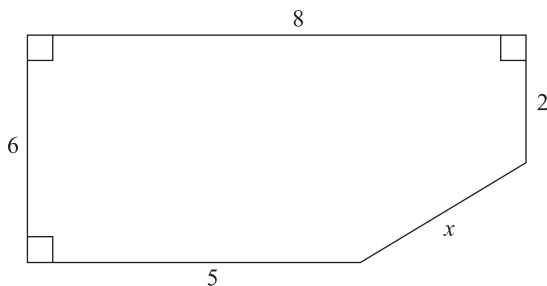

What is the perimeter of the above figure?

- (A) 24
- (B) 25
- (C) 26
- (D) 27
- (E) 28

18. Which of the following is the product of two prime numbers whose difference is twenty one?

- (A) 46
- (B) 51
- (C) 55
- (D) 57
- (E) 58

19. What is the distance from the midpoint of \overline{DE} to the origin, if $D(0,12)$ and $E(5,0)$?

- (A) 5
- (B) 6.5
- (C) 8.2
- (D) 12
- (E) 13

20. If $-b^2 = (b - 7)(b + 3) - (2b + 2)(b + 5)$, then b equals

- (A) $-1\frac{15}{16}$
- (B) $1\frac{3}{8}$
- (C) 2
- (D) $2\frac{10}{11}$
- (E) $5\frac{1}{3}$

21. Between 1950 and 2000, the population of Cree County tripled every ten years, except for the decade of the 1980s when the population of the country fell by one-half. If the population of Cree country was 1000 people in 1950, what is the population now?

- (A) 40,500
- (B) 72,900
- (C) 121,500
- (D) 218,700
- (E) 243,000

STOP

Do not proceed to the next section until time is up.

Section 3

30 Questions ■ Time—25 Minutes

Identifying Sentence Errors

Directions: Mark the letter of your choice on the answer sheet that best corresponds to the correct answer.

Notes:

1. The following questions test your knowledge of the rules of English grammar, as well as word usage, word choice, and idioms.
2. Some sentences are correct, but others contain a single error. No sentence contains more than one error.
3. Any errors that occur will be found in the underlined portion of the sentence. Choose the letter underneath the error to indicate the part of the sentence that must be changed.
4. If there is no error, pick answer choice (E).
5. There will be no change in any parts of the sentence that are not underlined.

1. The scientists found that there were less strands of the mold they were studying than they needed to conduct the experiment. No error

A
B C
D E

2. The painter gave a fantastic demonstration for Ada and I and we vowed to utilize the new technique in our own work. No error

A
B C
D E

3. The team, which is composed of four cyclists, compete against other cycling teams from around the nation and around the world. No error

A
B C D
E

4. Depending on which historian you read, the *Pax Romana* was either as long as five centuries or as short as three. No error

A B
C D E

5. Because they have extensively surveyed the
A
Lower Ohio Valley, Louis and Clark
B
were well prepared to navigate uncharted
C
territory along the Missouri River. No error
D E

6. The administrator suggested that the staff
first focus on contacting
A
prospective participants for the upcoming
B
seminar and then on follow-up with
C D
previous speakers. No error
E

7. The Ottoman Empire initiated better trade
A B
relations with the Austrian Empire when
its border disputes with Russia
C
were resolved (D). No error
D E

8. The census statistics was a complex source
A
of information, in that the demographers
B
knew that certain groups of people were
C
more likely to respond than others.
D
No error
E

9. Because of the large traffic jam, scarcely
A
no one from the group made it to the
B C
airport in time to catch the flight to the
D
conference in San Antonio. No error
E

10. Even though he had the title of
A
Vice-President of Operations, his duties
B
and responsibilities were not much greater
C
than a midlevel manager. No error
D E

Improving Sentences

Directions:

1. The following questions test your knowledge of English grammar, word usage, word choice, sentence construction, and punctuation.
2. Every sentence contains a portion that is underlined.
3. Any errors that occur will be found in the underlined portion of the sentence. If you believe there is an error, choose the answer choice that corrects the original mistake. Answer choices (B), (C), (D), and (E) contain alternative phrasings of the underlined portion. If the sentence contains an error, one of these alternate phrasings will correct it.
4. Choice (A) repeats the original underlined portion. If you believe the underlined portion does not contain any errors, select answer choice (A).
5. There will be no change in any parts of the sentence that are not underlined.

11. In an effort to make the Constitution both more accessible and understandable to the public, the House of Representatives has authorized the publication of a series of pamphlets about the Constitution.

- (A) both more accessible and understandable to the public
- (B) more both accessible and understandable to the public
- (C) more accessible to the public and more understandable for it
- (D) both more accessible and more understandable to the public
- (E) accessible to the public and understandable

12. Widely considered one of the most original poets of all time, Gerard Manley Hopkins's poems display utterly nonconventional systems of rhyme.

- (A) Gerard Manley Hopkins's poems display utterly nonconventional systems of rhyme.
- (B) Gerard Manley Hopkins's poems displayed utterly nonconventional systems of rhyme.
- (C) Gerard Manley Hopkins's poems have systems of rhyme that are utterly nonconventional.
- (D) Gerard Manley Hopkins wrote poems using utterly nonconventional systems of rhyme.
- (E) Gerard Manley Hopkins had written poems that were displaying utterly nonconventional systems of rhyme.

13. Eleanor Roosevelt, the wife of President Franklin D. Roosevelt, made an active contribution to many political organizations, this included the Human Rights Commission.

- (A) organizations, this included the Human Rights Commission.
- (B) organizations, being included the Human Rights Commission.
- (C) organizations, whose participation included the Human Rights Commission.
- (D) organizations; this including the Human Rights Commission.
- (E) organizations, including the Human Rights Commission.

14. Sputnik was the first artificial satellite successfully propelled into orbit and began the space race between the United States and the Soviet Union, in 1957 it was launched by the Soviets.

- (A) Sputnik was the first artificial satellite successfully propelled into orbit and began the space race between the United States and the Soviet Union, in 1957 it was launched by the Soviets.
- (B) In 1957, the first satellite and space race were beginning when Sputnik was launched.
- (C) Launched by the Soviets in 1957, Sputnik was the first artificial satellite successfully propelled into orbit, beginning the space race between the United States and the Soviet Union.
- (D) The launching of Sputnik was in 1957, the first artificial satellite was successfully propelled and the space race between the United States and the Soviet Union was begun.
- (E) The first artificial satellite successfully propelled into orbit was when Sputnik was launched in 1957, and the space race between the United States and the Soviet Union was begun as well.

15. The newly hired CEO stated clearly in her opening address to the company that her plans for reinvigorating the company were to cut back on discretionary spending, refinance the company's largest loans, and her plans of keeping the company's holdings in the stock market.
- (A) her plans of keeping the company's holdings in the stock market.
 - (B) keep the company's holdings in the stock market.
 - (C) to get the company to keep its holdings in the stock market.
 - (D) her plans to keep the company's holdings in the stock market.
 - (E) keeping the company's holdings in the stock market.
16. Typically, a restaurant's kitchen is divided into a number of sections, each with a particular aspect of food preparation performed there.
- (A) each with a particular aspect of food preparation performed there.
 - (B) each corresponding to a particular aspect of food preparation.
 - (C) where they each have their particular aspect of food preparation to perform.
 - (D) which has a particular aspect of food preparation performed there.
 - (E) they each correspond to a particular aspect of food preparation.
17. Domesticated over 5,000 years ago, the camel is a useful pack animal because of its tolerance for hot sand, extreme temperatures, and it needs little drinking water.
- (A) of its tolerance for hot sand, extreme temperatures, and it needs little drinking water.
 - (B) of its tolerance for hot sand and extreme temperatures and its need for water is very small.
 - (C) it can tolerate hot sand, extreme temperatures, and a lack of drinking water.
 - (D) it can tolerate hot sand, withstanding extreme temperatures, and needs little water.
 - (E) it can tolerate hot sand and extreme temperatures, and needs little water.
18. Legally, an agreement among two people to commit a crime or concealing it constitutes a criminal conspiracy.
- (A) among two people to commit a crime or concealing it
 - (B) among two people to commit a crime or agreeing to conceal it
 - (C) among two people committing a crime or concealing it
 - (D) between two people to commit a crime or conceal it
 - (E) between two people in the committing of a crime or the concealment of it

19. Not only was Sir Isaac Newton famous for his pioneering work in Physics, he was also a talented and well-respected economic advisor to the king.

- (A) he was also a talented and well-respected economic advisor to the king.
- (B) he had also been a talented and well-respected economic advisor to the king.
- (C) but he was also a talented and well-respected economic advisor to the king.
- (D) as he also was a talented and well-respected economic advisor to the king.
- (E) but he had also been a talented and well-respected economic advisor to the king.

20. If the high levels of stock market investment are to continue it will depend upon both how long the stock market remains stable and its long-term durability.

- (A) If the high levels of stock market investment are to continue it will depend
- (B) If the high levels of stock market investment are to continue, depending upon
- (C) If the high levels of stock market investment continue, it will depend
- (D) Whether the high levels of stock market investment continue will depend
- (E) Whether the high levels of stock market investment continue it will depend

Improving Paragraphs

Directions:

1. The following questions test your knowledge of paragraph and sentence construction.
2. The following passage is a rough draft of an essay. This rough draft contains various errors.
3. Read the rough draft and then answer the questions that follow. Some questions will focus on specific sentences and ask if there are any problems with that sentence's word choice, word usage, or overall structure. Other questions will ask about the paragraph itself. These questions will focus on paragraph organization and development.
4. Select the answer that best reflects the rules of English grammar and proper essay and paragraph writing.

Questions 21–25 are based on the following passage.

The following passage is part of an essay about the different meanings of the word “modern.”

Line (1) The word *modern* is a curious word
(2) It is curious for all its different
meanings. (3) If you take a freshman
class in philosophy, for instance, your
(5) professor might tell you about Rene
Descartes. (4) Descartes was a French
philosopher from the seventeenth
century. (5) Many consider him as the
first figure in modern philosophy. (6) So
(10) if you are talking to a philosophy
professor the word *modern* denotes
anytime between about 1615 and now.
(7) (Of course, some philosophers think
that modern times ended a few decades
(15) back and that we are already in to
postmodern times.) (8) Other academics
have a different timeline for the birth of
modern times, or modernity. (9) And
some historians point to the Industrial
(20) Revolution in England as the beginning
of modernity. (10) This dating technique
puts the beginning of modernity at least a

century after when the philosophers
reckon the beginning of modern times.

(25) (11) The philosophers and the historians
have a bit of a discrepancy here.

(12) Of course, you might think both
the philosophers and the historians are a
bit off on this whole modernity thing.

(30) (13) Who thinks of the mud and cobble-
stone streets of Paris in the early decades
of the seventeenth century as modern?

(14) Then again, London a century later
with the power of steam harnessed does

(35) not strike most as the picture of modern
times. (15) Most of us, when we think of
what modern means, we are thinking

about computers and cell phones and
wireless networks. (16) We are not

(40) thinking about some philosophical
discourse that a Frenchman wrote four
centuries back.

21. Which of the following is the best combination of sentences 1 and 2 (reproduced below)?

The word *modern* is a curious word. It is curious for all its different meanings.

- (A) The word *modern* is a curious word. It is curious for all its different meanings.
 - (B) *Modern* is a curious word because it has all its different meanings.
 - (C) It is curious that the word *modern* has various different meanings.
 - (D) Curiously, the word *modern* has many different meanings.
 - (E) *Modernity* is a curious word for all its various different meanings.
22. Which of the following is the best way to revise sentences 4 and 5 (reproduced below) so that they are condensed into one sentence?

Descartes was a French philosopher from the seventeenth century. Many consider him as the first figure in modern philosophy.

- (A) Descartes was a French philosopher from the seventeenth century, considering him the first figure in modern philosophy.
- (B) Descartes was a French philosopher from the seventeenth century, whom many consider the first figure in modern philosophy.
- (C) Descartes was a French philosopher from the seventeenth century, and many consider him the first figure in modern philosophy.
- (D) Descartes was a French philosopher from the seventeenth century, so he was the first figure in modern philosophy.
- (E) Descartes was a French philosopher from the seventeenth century and figuring him the first figure in modern philosophy.

23. Which of the following would be the best replacement for “And” at the beginning of sentence 9 (reproduced below)?

And some historians point to the Industrial Revolution in England as the beginning of modernity.

- (A) However,
 - (B) Moreover,
 - (C) Even so,
 - (D) Considering this,
 - (E) For example,
24. Which of the following is the best revision of the underlined portions of sentence 10 (reproduced below)?

This dating technique puts the beginning of modernity at least a century after when the philosophers reckon the beginning of modern times.

- (A) As it is now.
- (B) at least a century after when the philosophers reckon it.
- (C) at least a century after when the philosopher’s date modernity’s inception.
- (D) at least one century after when the philosophers had reckoned the inception of modernity.
- (E) at least a century after its having been reckoned by the philosophers.

25. Which of the following is the best revision of sentence 15 (reproduced below)?

Most of us, when we think of what modern means, we are thinking about computers and cell phones and wireless networks.

- (A) As it is now.
- (B) Most of us, when we think of what modern means, computers and cell phones and wireless networks coming to mind.
- (C) When we think of what modern means, think about computers and cell phones and wireless networks.
- (D) Most of us, when we think of what modern means, we are thinking about computers, cell phones, wireless networks.
- (E) Most of us, when we think of what modern means, think about computers and cell phones and wireless networks.

Questions 26–30 are based on the following passage.

The following is a first draft of an essay about the growth of the department store industry in the 1920s.

Line (1) Automobiles and radios became far more affordable in the 1920s. (2) By 1925 there was one automobile for every six people in the United States, by 1930 (5) this had increased to one for every 4.6 people. (3) Also by 1930, about 4 in 10 American families owned radios. (4) The popularity of automobiles and radios led to the spread of chain stores of all kinds. (10) (5) Automobiles allowed consumers to travel further in search of the right item for the right price, while radios allowed businesses to advertise their products to a

(15) larger group of people. (6) Those people could be potential consumers.

(7) Many of our most famous department store chains first expanded during this time. (8) These include Sears, Roebuck; Woolworth's; the Great (20) Atlantic and Pacific Tea Company (the A&P); and Walgreen Drug. (9) Among the most successful department stores was Filene's in Boston and Macy's in New York. (10) Initially, department (25) stores were more like the malls of today. (11) Each department was leased to an individual owner. (12) Nowadays, virtually all departments are run by the larger company, including restaurants.

(30) (13) Also, with their radio campaigns, the new department stores of the 1920s put on extravagant advertising spectacles. (14) Sometimes, they even hosted entertainment events to attract (35) consumers. (15) The Macy's Thanksgiving Day Parade, an attempt to capture the children's toy market, is one example of popular merchandising. (16) Bloomingdale's posted ads on all New York (40) public transit, pronouncing, "All Cars Transfer to Bloomingdale's."

26. Which of the following is the best revision of the underlined portions of sentences 5 and 6 (reproduced below)?

Automobiles allowed consumers to travel further in search of the right item for the right price, while radios allowed businesses to advertise their products to a larger group of people. Those people could be potential consumers.

- (A) As it is now.
- (B) a larger group of people, who could be potential consumers.
- (C) a larger group of people, being potential consumers.
- (D) a larger group of people, whom they made into potential consumers.
- (E) a larger group of people, having the potential to become consumers.

27. “This time” in sentence 7 (reproduced below) is best made more specific. Which of the following phrases is the best revision?

Many of our most famous department store chains first expanded during this time.

- (A) these years
- (B) the twentieth century
- (C) the same when automobile sales and radio sales were also on the rise
- (D) the years described in the previous paragraph
- (E) the 1920s

28. If you were to combine sentences 10 and 11 (reproduced below), which would be the most appropriate and precise punctuation mark to use?

Initially, department stores were more like the malls of today. Each department was leased to an individual owner.

- (A) today ‘each. . . owner.’
- (B) today; each
- (C) today: each
- (D) today (each. . . owner).
- (E) today, each

29. Which of the following is the best revision of the underlined portion of sentence 13 (reproduced below)?

Also, with their radio campaigns, the new department stores of the 1920s put on extravagant advertising spectacles.

- (A) Moreover
- (B) Too
- (C) What’s more to their radio campaigns
- (D) In addition to their radio campaigns
- (E) The radio campaigns being included

30. Which of the following sentences, if added at the end of paragraph 3, is the best concluding sentence for the passage?

- (A) In the 20s, shopping and advertising started to look a lot like they do now.
- (B) Other stores also had extravaganzas.
- (C) So now get in your car and drive to a department store!
- (D) Department Stores having become huge successes.
- (E) Macy’s Thanksgiving Day Parade was always a big hit.

STOP

Do not proceed to the next section until time is up.

Section 4

27 Questions ■ Time—25 Minutes

Directions: Each sentence below has either one or two blanks in it and is followed by five choices, labeled (A) through (E). These choices represent words or phrases that have been left out. Choose the word or phrase that, if inserted into the sentence, would best fit the meaning of the sentence as a whole.

Example:

Canine massage is a veterinary technique for calming dogs that are extremely _____.

- (A) inept
- (B) disciplined
- (C) controlled
- (D) stressed
- (E) restrained

(A) (B) (C) (D) (E)

1. Jerome is a true _____ ; he rarely buys anything other than food, and even his food is plain and minimal.
 - (A) hermit
 - (B) teetotaler
 - (C) gourmand
 - (D) ascetic
 - (E) fanatic
2. The property tax hike in Colson County was not just _____ by the county residents; a series of protests were even _____.
 - (A) disliked. .organized
 - (B) espoused. .planned
 - (C) discouraged. .theorized
 - (D) bolstered. .analyzed
 - (E) detested. .negotiated

3. There was criticism that the councilman was _____ when he seized the ceremony _____ by the girl's tragic death to speak out against his opponent.
- (A) militaristic..negated
 (B) opportunistic..afforded
 (C) unreceptive..preempted
 (D) passive..created
 (E) defeatist..overshadowed
4. The computer expert underscored that the new software would _____ the prior version; users could simply _____ the old one.
- (A) preclude..destroy
 (B) outdo..implement
 (C) infect..disregard
 (D) undermine..detach
 (E) supercede..discard
5. Romania has a long and _____ tradition of activist-poets, who through poetry have _____ the dignity and equality of humanity.
- (A) reputable..initiated
 (B) storied..articulated
 (C) tenuous..supported
 (D) tactile..decried
 (E) exemplary..countered
6. Dr. Patel expected the surgery to be _____ and laborious, but it turned out to be speedy and _____.
- (A) fragile..simple
 (B) compelling..forthcoming
 (C) intricate..straightforward
 (D) complicated..locatable
 (E) hard..mechanical
7. Despite the longstanding _____ between the clans, both clans _____ each other in the aftermath of the disaster.
- (A) feud..assisted
 (B) grudge..maligned
 (C) detente..withstood
 (D) skirmish..ameliorated
 (E) alliance..discounted
8. The oral tradition of the Bambara people of West Africa is rich with humor and _____, characteristics which are evident in the merriment of their every-day life.
- (A) irony
 (B) mirth
 (C) cynicism
 (D) history
 (E) mystery
9. Although *Astropithicus* has more subspecies than *Pthicalitius*, the latter populates the Earth with _____ numbers and in more _____ geographic regions.
- (A) greater..diverse
 (B) lesser..secluded
 (C) milder..remote
 (D) scatter..familiar
 (E) larger..ominous
10. It is generally _____ by medical practitioners that the last few weeks of a pregnancy are crucial in the _____ of the fetus.
- (A) acknowledged..progression
 (B) hedged..health
 (C) endorsed..birthing
 (D) accepted..development
 (E) negated..vitality

11. Though the organization espoused outward-focused ideals, in practice, it was quite _____.

- (A) gregarious
- (B) vigilant
- (C) insular
- (D) hermetic
- (E) idiosyncratic

12. The prosecuting attorney described the defendant's character as _____ and base, but the defense attorney rejoined that the prosecution was _____ the testimonials about the defendant.

- (A) dark. .misunderstanding
- (B) nefarious. .misconstruing
- (C) lackluster. .misinterpreting
- (D) blustery. .misapplying
- (E) motley. .misrepresenting

13. Many believe that the new drug regime will be a _____ for helping cure diverse ailments related to spinal dysfunctions.

- (A) bane
- (B) panacea
- (C) module
- (D) fledgling
- (E) pariah

14. The executive charged that the whistleblower's actions were so self-centered that they were not just _____ but even _____.

- (A) self-involved. .altruistic
- (B) ill-tempered. .narcissistic
- (C) egocentric. .solipsistic
- (D) unduly. .respectable
- (E) erratic. .destructive

15. Technology, instead of alleviating the demands upon our time, has made the pace of modern-day life increase to a near _____ pace.

- (A) elicit
- (B) frenetic
- (C) lethargic
- (D) dilatory
- (E) cavalier

Questions 16–27 are based on the following passage.

The following passage tells the story of Juan Bautista Rael, an Hispanic-American scholar. It is adapted from a biography written by Enrique R. Lamadrid.

Line Linguist and folklorist Juan Bautista Rael was a highly regarded academic pioneer. His major contribution to linguistics was collecting and documenting the *Hispano* folk stories, plays, and religious traditions of northern New Mexico and southern Colorado.

(5) Rael was born on August 14, 1900, in Arroyo Hondo, New Mexico. Famous (10) for its spectacular setting north of Taos, the village lies in a deep, narrow valley between Taos mountain and the gorge of the Rio Grande to the west. His family prospered in sheep and cattle ranching and owned a mercantile business that served surrounding *Hispano* communities as well as nearby Taos Pueblo.

(15) Juan's parents, José Ignacio Rael and Soledad Santistevan, raised a family of (20) four sons and a daughter. José Ignacio had the foresight to recognize the changes that were coming with the increasing Americanization of New Mexico and realized that a fluent (25) knowledge of English and a good education would be necessary for his

family to excel. Since local schools were rudimentary at best, the family relied upon its own resources to get the best possible education for the children. Juan was a dedicated student from his earliest years, and his father's ambition was for him to become a lawyer and tend to the family lands and business. Juan's elementary schooling was at Saint Michael's College in Santa Fe, and his high school studies were at the Christian Brothers' College in St. Louis, Missouri. The boy's semester-long absences from his family led him to treasure the simple pleasures of village life. Summers are especially beautiful in Arroyo Hondo, and Christmas and Easter vacations were filled with colorful festivities and solemn ceremony. Rael later reminisced about how much the *Pastores*, or Shepherds' plays, impressed him as a child. Undoubtedly, the instincts and sympathies of Rael the folklorist can be traced to these beginnings—watching rehearsals and performances depicting shepherds, hermits, and the rich ensemble of pastoral characters.

What became clear in his post-secondary studies is that he was much more attracted to literature, philology, and the emerging disciplines of linguistics and folklore. His Bachelor's degree, from St. Mary's College in Oakland in 1923, led to a Master's degree from the University of California at Berkeley in 1927. In the meantime, in 1923, he married Quirina Espinoza of Antonito, Colorado. Rael's first inclination was to become an English teacher, but his bride helped convince him that his opportunities and strengths would be as an Hispanist. After deciding on a university career of teaching and research, Rael

(70) relinquished his family inheritance in land, cattle, and sheep to his three brothers and his sister.

Rael realized that the wealth in northern New Mexico that interested him was the vast repertory of folk narrative, song, and custom that had scarcely been documented. While teaching at the University of Oregon, he returned to Arroyo Hondo in the summer of 1930 to begin compiling his famous collection of over five hundred *Nuevo Mexicano* folk tales.

By then his work had attracted the attention of pioneer *Hispano* folklorist Aurelio Espinosa who invited Rael to Stanford in 1933. Rael completed his doctoral studies in 1937 there with a dissertation on the phonology and morphology of New Mexico Spanish that amplified the work of Espinosa with the huge corpus of folk tales, later published as, *Cuentos Españoles de Colorado y Nuevo Mexico: Spanish Folk Tales of Colorado and New Mexico*.

Well versed in the historic-geographic theory of transmission and diffusion of motifs, tale types, and genres, Dr. Rael set out on the formidable, almost quixotic task of gathering all the possible versions and texts of the tales, hymns, and plays he was studying. The vast majority of tales are of European provenance, with only minimal local references. He meticulously traced the shepherds' plays to several root sources in Mexico, and his study, *The Sources and Diffusion of the Mexican Shepherds' Plays*, is a standard reference on the subject. His ground-breaking study of the *alabado* hymn, *The New Mexican Alabado*, is also a prime resource. But inevitably the historic-geographic

(115) approach led more to collection building than to analysis. Later generations of scholars would develop interests in performance-centered studies, but the collections of Rael continue to be an indispensable landmark in the field.

16. The author's attitude towards Dr. Rael's work can best be described as
- (A) laudatory.
 - (B) engaged.
 - (C) ambivalent.
 - (D) disinterested.
 - (E) condescending.
17. The passage primarily
- (A) analyzes the academic contributions of Dr. Rael.
 - (B) contrasts Dr. Rael's work with the work of Dr. Espinosa.
 - (C) tells the story of Dr. Rael's life and work.
 - (D) discusses the basic assumptions of *Hispano* scholarship.
 - (E) relates the story of the Rael family.
18. The passage implies that Rael decided that he would have more opportunity as a Hispanist than as an English teacher because
- (A) Hispanics weren't often hired to teach English.
 - (B) Hispanic folklore would soon vanish.
 - (C) he would have to live far from his family to teach English.
 - (D) his English skills were mediocre.
 - (E) becoming an Hispanist was a nearer match to his educational background.
19. The author probably uses the word "relinquished" in line 70 to emphasize that
- (A) Rael had had friction with his siblings.
 - (B) Rael's family was very wealthy.
 - (C) Rael had tried to be a rancher for some time.
 - (D) Rael was relieved to be free of his family duties.
 - (E) Rael's career path was difficult and not lucrative.
20. It can be inferred from the passage that northern New Mexico in the early decades of the twentieth century
- (A) had a ranch-driven economy.
 - (B) was suffering severe economic depression.
 - (C) was economically booming because of a newly opened southern railroad route to California.
 - (D) had a strong public education system.
 - (E) was not a primarily English-speaking region.
21. Which of the following best describes Dr. Espinosa's relationship to Dr. Rael?
- (A) Boss
 - (B) Critic
 - (C) Mentor
 - (D) Pastor
 - (E) Father
22. The word "corpus" in line 91 most closely means
- (A) religious text.
 - (B) oeuvre.
 - (C) published collection.
 - (D) dissertation.
 - (E) dialect.

23. According to the passage, which of the following of Dr. Rael's activities as a young man was most important for the development of his later academic interests?
- (A) Working on his family's ranch
 - (B) Watching *Pastores* as a young man
 - (C) Studying in a religious school
 - (D) Reading books on the shepherds of northern New Mexico
 - (E) Struggling to retain his Spanish when his schooling was in English
24. The phrase "diffusion of motifs" in lines 96–97 refers to
- (A) variations in the same stories that occur over time or by region.
 - (B) adherence to standard literary structures.
 - (C) variations in language use by region.
 - (D) the surprising similarity of stories in different cultures.
 - (E) the loss of folklore in more industrialized societies.
25. The word "provenance," line 103, could best be replaced with which of the following words?
- (A) Authority
 - (B) Origin
 - (C) Location
 - (D) Destiny
 - (E) Ethos
26. The main criticism the author offers of Dr. Rael's work is that it
- (A) focuses too much on the *Pastores*.
 - (B) privileges Spanish-language stories over English-language stories.
 - (C) focuses too much on European stories and not enough on Mexican stories.
 - (D) doesn't offer enough analysis of the folklore.
 - (E) includes too many materials, without differentiating between good and bad.
27. The passage suggests, in lines 97–101 that Dr. Rael
- (A) was mistaken about how much folklore was circulating.
 - (B) traveled extensively as he gathered folklore.
 - (C) was disorganized but intelligent in his methods.
 - (D) had an historic insight about the source of New Mexican folklore.
 - (E) developed an excessively technical model for the development of folklore.

STOP

Do not proceed to the next section until time is up.

Section 5

21 Questions ■ Time—25 Minutes

Directions: Solve the following problems using any available space on the page for scratchwork. Mark the letter of your choice on the answer sheet that best corresponds to the correct answer.

Notes:

1. You may use a calculator. All of the numbers used are real numbers.
2. You may use the figures that accompany the problems to help you find the solution. Unless the instructions say that a figure is not drawn to scale, assume that it has been drawn accurately. Each figure lies in a plane unless the instructions say otherwise.

Reference Information

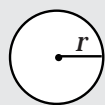

$$A = \pi r^2$$

$$C = 2\pi r$$



$$A = \ell w$$

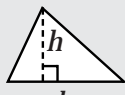

$$A = \frac{1}{2}bh$$



$$V = \ell wh$$

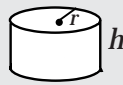

$$V = \pi r^2 h$$

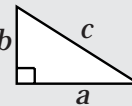

$$c^2 = a^2 + b^2$$

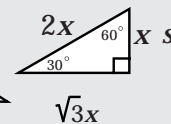

Special Right Triangles

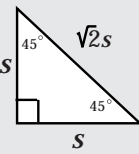

The number of degrees of arc in a circle is 360.

The measure in degrees of a straight angle is 180.

The sum of the measures in degrees of the angles of a triangle is 180.

1. At full capacity, Thompson Paper Factory produces 200 sheets of paper per second. If the factory is operating at a quarter of its full capacity, how many sheets of paper will the factory produce in twelve seconds?

- (A) 600
(B) 900
(C) 1200
(D) 2000
(E) 2400

2. If $Z = \frac{2x}{5}$ and $Z = 3$, then $x =$

- (A) $\frac{5}{3}$
(B) 2
(C) 5
(D) $\frac{19}{3}$
(E) $\frac{15}{2}$

3. Which of the following is the greatest common factor of 32 and 42?

- (A) 2
- (B) 3
- (C) 6
- (D) 8
- (E) 12

4.

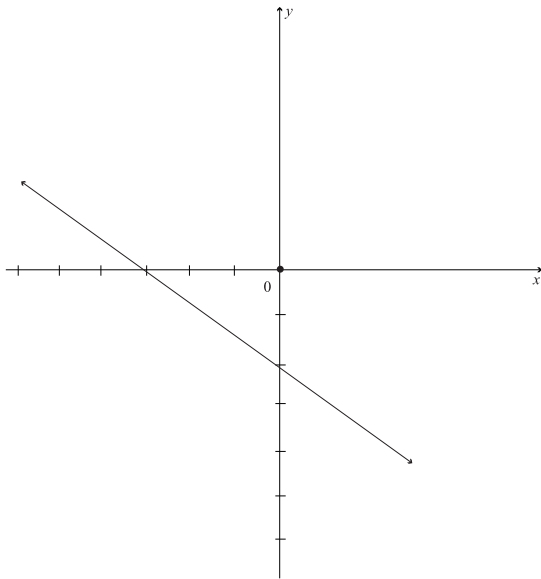

What is the slope of the above line?

- A. $-\frac{3}{2}$
- B. $-\frac{2}{3}$
- C. $\frac{2}{3}$
- D. 1
- E. $\frac{3}{2}$

Questions 5–6 refer to the following table.

5.

3rd and 4th Graders at
Hyde Park Elementary

	Boys	Girls	Total
3rd	16	14	
4th			32
Total			

According to the table, how many students are there in 3rd and 4th grade at Hyde Park Elementary?

- (A) 30
- (B) 32
- (C) 50
- (D) 60
- (E) 62

6. If there are 18 girls in 4th grade, how many boys are there in 3rd and 4th grade at Hyde Park Elementary?

- (A) 18
- (B) 22
- (C) 26
- (D) 30
- (E) 32

7. Which of the following is the value of the exponent when the expression $\frac{(m^3)^{-2}}{m^4}$ is simplified?

- (A) $-\frac{11}{4}$
- (B) $-\frac{29}{16}$
- (C) $-\frac{3}{4}$
- (D) $\frac{11}{4}$
- (E) $\frac{29}{6}$

8.

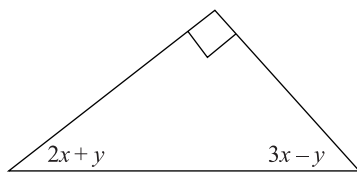

In the right triangle above, what is the value of x ?

- (A) 15
 - (B) 16
 - (C) 18
 - (D) 24
 - (E) 30
9. Taking the highway from Easton to Bethsaida is 7 miles longer than taking surface streets from Easton to Bethsaida. It is 31 miles total if you travel from Easton to Bethsaida via highway and return via surface streets. How many miles then, is the highway route?
- (A) 12
 - (B) 13
 - (C) 15
 - (D) 17
 - (E) 19

10. If $f(x) = \frac{3x^2}{x^2 + 3x - 18}$, for what values of x is the function undefined?

- (A) 0
- (B) $-3, 6$
- (C) $-3, 3$
- (D) $2, 5$
- (E) $3, -6$

11.

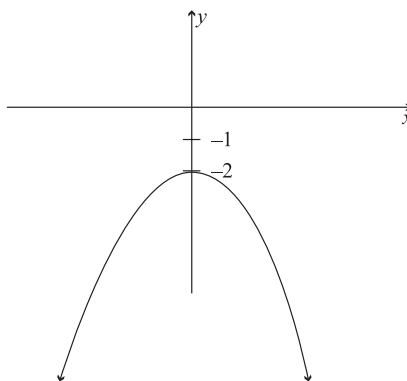

If $f(x)$ is graphed above, then $f(x) =$

- (A) $x^2 + 2$
- (B) $x^2 - 2$
- (C) $-x^2 + 2$
- (D) $-(x^2 + 2)$
- (E) $-(x + 2)^2$

12.

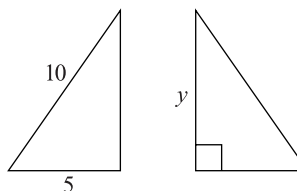

If the above triangles are congruent, what is the value of y ?

- (A) 5
- (B) $\sqrt{50}$
- (C) 8
- (D) $\sqrt{75}$
- (E) 9

13. $(y + 2)^2 = (y - 4)^2$ is true when y equals

- (A) 1 only
- (B) 1 and -1
- (C) 2 and -2
- (D) 1 and 2
- (E) 2 and 4

14. Z is the set of numbers 1 through 50 inclusive. How many members of Z are evenly divisible by 2 and 3?

- (A) 6
- (B) 8
- (C) 14
- (D) 16
- (E) 25

15.

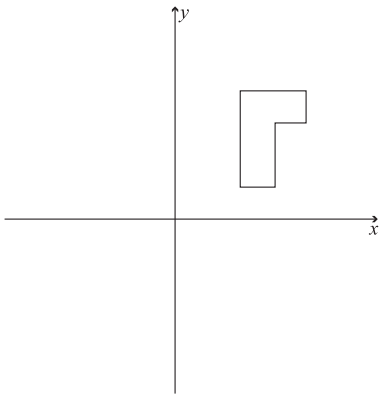

Which of the following figures is similar to the shape shown above?

(A)

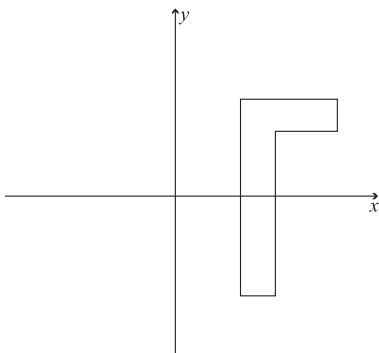

(B)

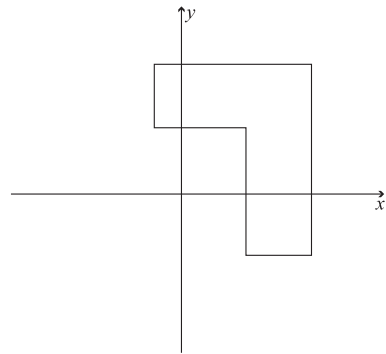

(C)

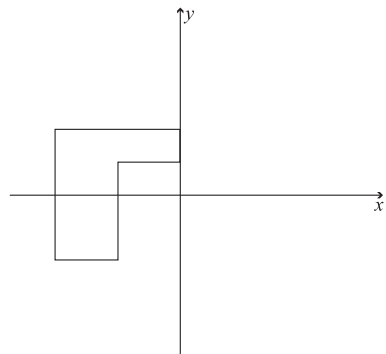

(D)

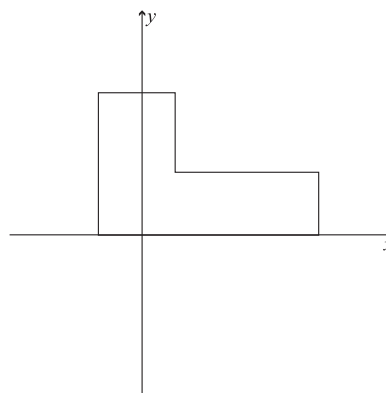

(E)

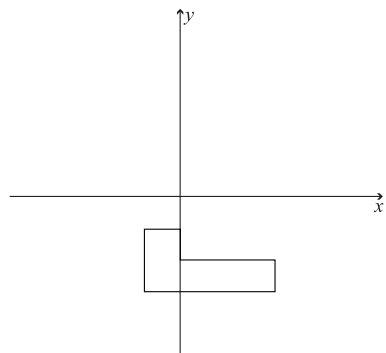

16.

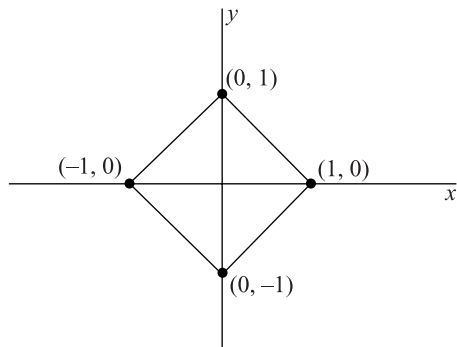

What is the area of the above figure?

- (A) 1
- (B) $\sqrt{2}$
- (C) 2
- (D) $1\sqrt{2}$
- (E) 4

17. The sum of eight positive even integers is 50. If no integer can appear more than twice in the set, what is the greatest possible value of one of the integers.

- (A) 8
- (B) 18
- (C) 22
- (D) 24
- (E) 32

18.

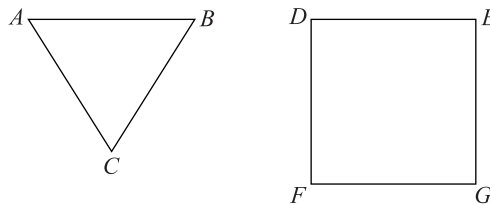

ABC is an equilateral triangle and $DEFG$ is a square. If $\overline{AB} = \overline{DE}$, how many different ways can ABC be placed in $DEFG$ such that two vertices of the triangle coincide with two corners of the square?

- (A) 4
- (B) 6
- (C) 8
- (D) 10
- (E) 12

19. G , S , and T are three points that lie on a plane. If the distance between G and S is 9, and the distance between S and T is 5, which of the following are possible distances between G and T ?

- I. 3
 - II. 5
 - III. 14
- (A) I only
 - (B) II only
 - (C) I and II only
 - (D) II and III only
 - (E) I, II, and III

20.

$B \bullet$

$A \bullet$

$D \bullet$

$C \bullet$

If $\overline{AB} = \overline{BC} = \overline{AC} = 6$, and D is the halfway between A and C , then $\overline{BD} =$

- (A) $2\sqrt{3}$
- (B) 3
- (C) $3\sqrt{3}$
- (D) $4\sqrt{2}$
- (E) $4\sqrt{3}$

21.

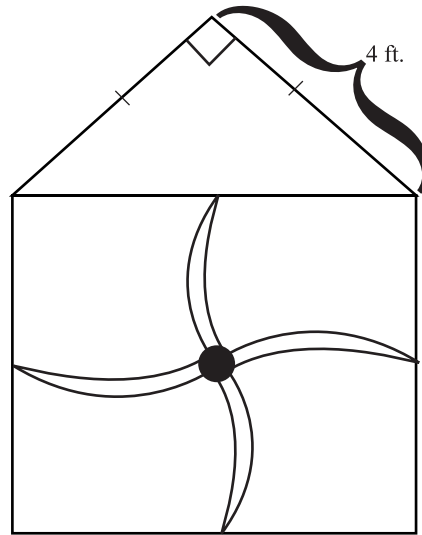

The figure above is the diagram of an industrial fan blade. If the fan's maximum blade speed is 100 revolutions per 10 seconds, what is the greatest distance (in feet) that any point on the blade could travel in 30 seconds?

- (A) $100\sqrt{2}\pi$
- (B) $200\sqrt{3}\pi$
- (C) $600\sqrt{2}\pi$
- (D) $600\sqrt{3}\pi$
- (E) $1200\sqrt{2}\pi$

STOP

Do not proceed to the next section until time is up.

Section 6

16 Questions ■ Time—20 Minutes

Directions: Each passage below is followed by a set of questions. Read each passage, then answer the accompanying questions, basing your answers on what is stated or implied in the passage and any introductory material provided. Mark the letter of your choice on the answer sheet that best corresponds to the correct answer.

Line Frederic Remington (1861–1909) has
long been celebrated as one of the most
gifted interpreters of the American West.
Initially, his western images appeared as
(5) illustrations in popular journals. As he
matured, however, Remington turned his
attention away from illustration,
concentrating instead on painting and
sculpture. About 1900 he began a series
(10) of paintings that took as their subject the
color of night. Before his premature
death in 1909 at age 48, Remington
completed more than seventy paintings in
which he explored the technical and
(15) aesthetic difficulties of painting darkness.

1. The passage suggests Remington's major artistic accomplishments were
- (A) magazine illustrations.
 - (B) sculptures.
 - (C) paintings of nocturnal cityscapes.
 - (D) paintings of nocturnal landscapes.
 - (E) color studies.

Line The question of what counts as literature
has been strongly debated over the last
few decades both in and out of academia.
Some argue that only the test of time
(5) ultimately vindicates a fictional work's
claim to the status of literature. Their
argument runs like this: if people still
read, still reference, still care about a
work of fiction decades or even centuries
(10) after its original publication, then that
work clearly rises to the auspicious status
of literature. Critics of this view, though,
point out that this method of determining
what is and is not literature by definition
(15) excludes contemporary works from
consideration. We do not know, they
rightfully contend, if a novel published in
the last few years will be read in a
hundred years or not. And so they ask,
(20) does this mean we cannot meaningfully
discuss whether the work is important, or
influential, or of great merit?

2. The author uses the word “vindicates” to emphasize that
- (A) all works of fiction claim to be literature.
 - (B) all works of fiction are, in some sense, literature.
 - (C) literature is a much more prestigious category than fiction.
 - (D) the debate regarding what is literature is excessively erudite.
 - (E) for a work to establish itself as literature is an incredible feat.
3. The argument, given in the passage, against the “test of time” approach is that
- (A) it excludes by definition all writing that is not fictional.
 - (B) it does not take trends in critical interest into account.
 - (C) it excludes contemporary fiction from the discussion.
 - (D) it allows contemporary works to be considered alongside the great works of centuries past.
 - (E) it gives too much weight to popular opinion.

Line Since the sixteenth century, astronomers have recognized Mars for what it is—a relatively nearby planet not so unlike our own. The fourth planet from the sun and
(5) Earth’s closest neighbor, Mars has been the subject of modern scientists’ careful scrutiny with powerful telescopes, deep space probes, and orbiting spacecraft. In
(10) 1976, Earth-bound scientists were brought significantly closer to their subject of investigation when two Viking probes touched down on that red soil. The possibility of life on Mars, clues to the evolution of the solar system,
(15) fascination with the chemistry, geology, and meteorology of another planet—

these were considerations that led the National Aeronautics and Space Administration to Mars. Project Viking’s goal, after making a soft landing on Mars, was to execute a set of scientific investigations that would not only provide data on the physical nature of the planet but also make a first attempt at determining if detectable life forms were present.

4. Which of the following does the paragraph most emphasize as the motivation for the Viking trip to Mars?
- (A) Fascination with chemistry on another planet.
 - (B) Four-century-old interest in the planet.
 - (C) The advancement of space exploration.
 - (D) Possibility of a space station on Mars.
 - (E) Possibility of life on Mars.

Questions 5–16 are based on the following two passages.

The following two passages discuss the English and Metric systems of measurement.

Passage 1

Line It is an oft-repeated tale that the English measurement of the yard was standardized when an English royal stepped into disputes about the measurement’s length and declared the distance from his
(5) shoulder to the tip of his fingers as the standard yard. Unlike many colorful anecdotes from history, this one is true. Early in the twelfth century, the English king Henry I established the length of the yard as the distance from the tip of his nose to the tip of his outstretched thumb.
(10) In our scientific age such stories seem earthy at best and ridiculous at worst.

(15) But not all ancient units of measure have such arbitrary origins. The mile is a good example of this. Though the mile is today counted as part of the English system of measurement, the unit dates back to
(20) ancient Rome. The English word mile derives from the Latin term *mille*, which means one thousand. For the Romans, the *mille* was one thousand paces. A pace was two steps, or five feet roughly. This
(25) meant the *mille* was 5,000 feet. In medieval Europe, however, the 220-yard furlong became the dominant measurement used. To reconcile the two measurements, the mile was lengthened to be
(30) eight furlongs. This made the mile 5,280 feet. A sixteenth-century act of Parliament fixed this measurement for the mile.

It is true that the English system of measurement, the system that includes
(35) the mile, the yard, the foot, and the inch, has a certain quirkiness to it because it has evolved through human history. This quirkiness might irritate scientists, but it is part and parcel of the tradition that
(40) has been bequeathed, in its accumulated form, to the English-speaking world.

Passage 2

The metric system was conceived by twelve French scientists during the French Revolution. Like many innova-
(45) tions during the French Revolution, the metric system was formulated as a scientific system that would replace traditional ways of ordering society. The revolutionaries did not see it as a
(50) coincidence that length was meted in measures based on the size of a medieval king. Instead of these arbitrary standards, the metric system's basic unit of measure, the meter, was based upon the circumfer-
(55) ence of the Earth. For the meter to be a

manageable size, it was defined as one one-forty-millionth of the Earth's circumference. They employed the word *meter* to harken back to the ancient
(60) Greek word *metron*, meaning measure.

The rest of the metric system is even less arbitrary in origin. The other metric units of length were generated by either multiplying or dividing the meter by a
(65) factor of ten. Thus a kilometer is 1000 meters, and a centimeter is one one-hundredths of a meter. It is the great asset of the metric system, at least for scientists, that units for measuring weight and energy are also derived from the basic
(70) unit of the meter. For instance, weight is measured in grams, which are determined by the weight of one cubic centimeter of water.

France made use of the metric system compulsory in 1840. Other countries rapidly followed suit. The adoption of the metric system, also known as the international system, or S.I., coincided
(80) with great advances in science. By 1900, over 35 countries had officially adopted its use. In the United States, the system has been dubbed "voluntary" and "preferred," but has never been made
(85) compulsory.

The measure of the meter has been refined three times since its conception in 1791. The latest was in 1983 when the speed of light was employed to give the
(90) greatest precision for the measurement to date. The distance that light travels in a vacuum in $1/299,792,458$ of a second is the internationally accepted definition of a meter.

5. What is the author of Passage 1's attitude towards the English system of measurement?
- (A) Emphatic praise
 - (B) Qualified acceptance
 - (C) Neutrality
 - (D) Strong criticism
 - (E) Antipathy
6. In Passage 1, the story of Henry I is offered primarily to
- (A) demonstrate that the reader's preconceptions about the English system are wrong.
 - (B) illustrate the role of the English monarchy in the development of the English system.
 - (C) reveal how far back in time the English system goes.
 - (D) provide a concrete example of how the arbitrariness of the English system developed.
 - (E) suggest the practicality of the English system.
7. The word "earthy" in line 14 most closely means
- (A) unrefined.
 - (B) musky.
 - (C) impractical.
 - (D) old-fashioned.
 - (E) baffling.
8. By "reconcile the two measurements," (line 28–32) the author means
- (A) determine which one was accurate.
 - (B) develop a new system of measurement without the inaccuracies of the old.
 - (C) settle the public's disagreement over which was better.
 - (D) find a metric equivalent.
 - (E) cease using two different systems.
9. The author refers to the English system's "accumulated form" line 40–41 primarily to emphasize that the system
- (A) ceased to change once officially adopted.
 - (B) derives from a variety of sources.
 - (C) stretches back further than reliable written history.
 - (D) continues to evolve.
 - (E) was adopted wholesale.
10. The authors of the two passages would be most likely to agree that the metric system
- (A) has a shorter but equally interesting history as the English system.
 - (B) has a history that reaches back as far as the English system's.
 - (C) has a longer history than the history of the English system.
 - (D) should not be thought of historically.
 - (E) has a history that is equally long but less colorful than the English system's.

11. According to Passage 2, the invention of the metric system was
- (A) one of the greatest accomplishments of the French Revolution.
 - (B) in contradiction to many of the other goals of the French Revolution.
 - (C) a side-effect of the French Revolution's new calendar system.
 - (D) one of many anti-traditionalist undertakings of the French Revolution.
 - (E) left incomplete at the end of the French Revolution.
12. In the sentence beginning "In the United States. . ." (line 82) the writer suggests that the United States
- (A) has never seriously attempted to implement the metric system.
 - (B) is likely to adopt the metric system fairly soon.
 - (C) has created official policies regarding use of the metric system.
 - (D) has attempted to require use of the metric system, but has been unable to enforce its policies.
 - (E) reflects a clear bias for the superiority of the English system.
13. The word "refined" in line 87 most closely means
- (A) processed.
 - (B) renegotiated.
 - (C) made smaller.
 - (D) challenged.
 - (E) modified.
14. In Passage 2, the reason for the 1983 definition of the meter is probably that scientists
- (A) have determined that the new meter is a more manageable length.
 - (B) have more sophisticated data on the circumference of the earth.
 - (C) needed a way to bring the meter's length closer to the yard's.
 - (D) have developed more accurate ways to calculate the original fraction.
 - (E) wanted to disassociate the meter with the French Revolution.
15. In at least one of the passages all of the following are mentioned EXCEPT
- (A) the kings who ruled during the standardization of measurements.
 - (B) the contemporary standing of the measuring system discussed.
 - (C) terms from ancient languages.
 - (D) the refinement of measurement standards in recent years.
 - (E) the cultural heritage of each measuring system.
16. The author of Passage 2 conveys an implicit belief that the
- (A) metric system facilitates scientific endeavors.
 - (B) United States has damaged its reputation in the international community by refusing to adopt the metric system.
 - (C) metric system is best confined to scientific use.
 - (D) French Revolution was a high point in the history of science.
 - (E) metric system is a more fitting system for a democratic society.

STOP

Do not proceed to the next section until time is up.

Section 7

13 Questions ■ Time—20 Minutes

Notes:

1. All numbers used are real numbers.
2. All angle measurements can be assumed to be positive unless otherwise noted.
3. All figures lie in the same plane unless otherwise noted.
4. Drawings that accompany questions are intended to provide information useful in answering the question. The figures are drawn closely to scale unless otherwise noted.

Directions for Student Produced Responses

Enter your responses to questions 1–13 in the special grids provided on your answer sheet. Input your answers as indicated in the directions below.

Answer: $\frac{4}{9}$ or 4/9

Write answer →
in boxes.

	4	/	9	
	<input type="radio"/>	<input checked="" type="radio"/>	<input type="radio"/>	
	<input type="radio"/>	<input type="radio"/>	<input type="radio"/>	<input type="radio"/>
Grid in → result.	<input type="radio"/>	<input type="radio"/>	<input type="radio"/>	<input type="radio"/>
	<input type="radio"/>	<input type="radio"/>	<input type="radio"/>	<input type="radio"/>
	<input type="radio"/>	<input type="radio"/>	<input type="radio"/>	<input type="radio"/>
	<input type="radio"/>	<input type="radio"/>	<input type="radio"/>	<input type="radio"/>
	<input checked="" type="radio"/>	<input type="radio"/>	<input type="radio"/>	<input type="radio"/>
	<input type="radio"/>	<input type="radio"/>	<input type="radio"/>	<input type="radio"/>
	<input type="radio"/>	<input type="radio"/>	<input type="radio"/>	<input type="radio"/>
	<input type="radio"/>	<input type="radio"/>	<input type="radio"/>	<input type="radio"/>
	<input type="radio"/>	<input type="radio"/>	<input checked="" type="radio"/>	<input type="radio"/>

← Fraction line

Answer: 1.4

Either position is correct.

Decimal →
point

	1	.	4	
	<input type="radio"/>	<input checked="" type="radio"/>	<input type="radio"/>	
	<input type="radio"/>	<input type="radio"/>	<input type="radio"/>	<input type="radio"/>
Decimal → point	<input type="radio"/>	<input type="radio"/>	<input type="radio"/>	<input type="radio"/>
	<input type="radio"/>	<input type="radio"/>	<input type="radio"/>	<input type="radio"/>
	<input type="radio"/>	<input type="radio"/>	<input type="radio"/>	<input type="radio"/>
	<input type="radio"/>	<input type="radio"/>	<input type="radio"/>	<input type="radio"/>
	<input type="radio"/>	<input type="radio"/>	<input type="radio"/>	<input type="radio"/>
	<input type="radio"/>	<input type="radio"/>	<input type="radio"/>	<input type="radio"/>
	<input type="radio"/>	<input type="radio"/>	<input type="radio"/>	<input type="radio"/>

		1	.	4
	<input type="radio"/>	<input checked="" type="radio"/>	<input type="radio"/>	
	<input type="radio"/>	<input type="radio"/>	<input type="radio"/>	<input type="radio"/>
Decimal → point	<input type="radio"/>	<input type="radio"/>	<input type="radio"/>	<input type="radio"/>
	<input type="radio"/>	<input type="radio"/>	<input type="radio"/>	<input type="radio"/>
	<input type="radio"/>	<input type="radio"/>	<input type="radio"/>	<input type="radio"/>
	<input type="radio"/>	<input type="radio"/>	<input type="radio"/>	<input type="radio"/>
	<input type="radio"/>	<input type="radio"/>	<input type="radio"/>	<input type="radio"/>
	<input type="radio"/>	<input type="radio"/>	<input type="radio"/>	<input type="radio"/>
	<input type="radio"/>	<input type="radio"/>	<input type="radio"/>	<input checked="" type="radio"/>

Note: You may begin your answer in any column, space permitting. Leave blank any columns not needed.

- Writing your answer in the boxes at the top of the columns will help you accurately grid your answer, but it is not required. **You will only receive credit for an answer if the ovals are filled in properly.**
- Only fill in one oval in each column.

- If a problem has several correct answers, just grid in one of them.
- There are no negative answers.
- **Never grid in mixed numbers.** The answer $3\frac{1}{5}$ must be gridded as 16/5 or 3.2. If

3	1	/	5
○	○	●	○
○	○	○	○
○	○	○	○
○	○	○	○
○	○	○	○
○	○	○	○
○	○	○	○
○	○	○	○
○	○	○	○

is gridded, it will be read as $\frac{31}{5}$, not $3\frac{1}{5}$.

Decimal Accuracy

Decimal answers must be gridded as accurately as possible. The answer 0.3333 . . . must be gridded as .333.

Less accurate values, such as .33 are not acceptable.

Acceptable ways to grid $\frac{1}{3} = .3333 \dots$

1	/	3	
○	○	○	○
○	○	○	○
○	○	○	○
○	○	○	○
○	○	○	○
○	○	○	○
○	○	○	○
○	○	○	○
○	○	○	○

.	3	3	3
○	○	○	○
○	○	○	○
○	○	○	○
○	○	○	○
○	○	○	○
○	○	○	○
○	○	○	○
○	○	○	○
○	○	○	○

1. If $2\sqrt{x} + \sqrt{x} = y$ and $2y = 12$, then what does x equal?
2. What is the product of the first five even integers?
3. Rider High has 400 students. A student will be picked at random from the student body. If the probability that a senior would be picked is three-eighths, how many seniors are there?

4.

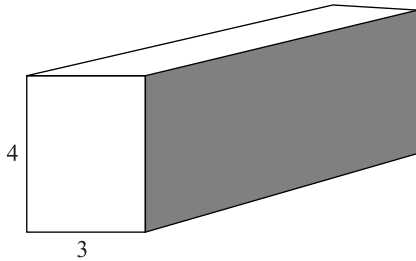

If the area of the striped side of the rectangular solid is 24, what is the volume of the box?

5. If the area of a circle is 16π , what is the diameter of the circle?
6. Lisa has three pizza toppings from which to choose: pepperoni, anchovies, and red peppers. If she can choose as many toppings as three and as few toppings as zero, how many different pizza orders are possible? (Lisa cannot order the same topping twice.)
7. The average (arithmetic mean) of five numbers is 16. If one number is taken from the set, the new average is 14. What number was taken from the set?

8.

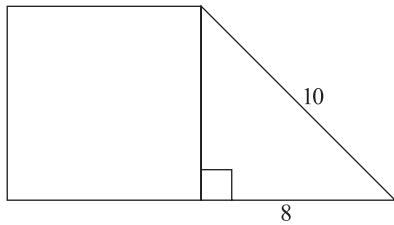

If the figure above is composed of a square and a triangle, what is the area of the square?

9. What is the slope a line that is defined by the following two points, $(-1, -2)$ and $(3, 1)$?
10. Tom is twelve years older than Susan, and Susan is three times the age of Gina, and Gina is five years younger than Bo. If Bo is 15, how old is Tom?
11. For all positive integers, let m^* equal the greatest prime divisor of m . What does $(15^*)(12^*)$ equal?

12.

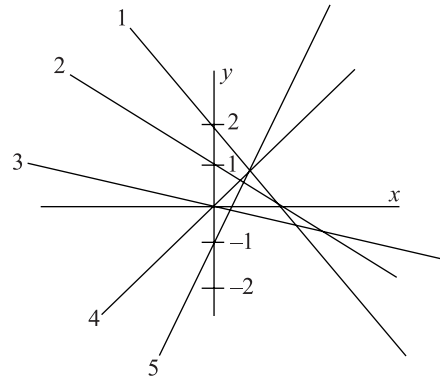

What is the sum of the y -intercepts in the above graph?

13. The sum of four positive distinct prime numbers is 21. What is the greatest possible value of one of those prime numbers?

STOP

Do not proceed to the next section until time is up.

Section 8

Time—25 Minutes

Directions: Think carefully about the statement below and the assignment that follows it.

Consider the following statement.

Innovation is primarily accomplished by an individual, though groups often do work out the details of an individual’s innovations.

Assignment: Write an essay in which you argue for or against the preceding statement. Develop your point of view on this statement and be sure to support your stance with sufficient details.

STOP

When you are finished with your essay put your pencil down until the time allotted is over.

Answers and Explanations

Section 1

- 1. B** The passage says that H.R. means House of Representatives and that the number is given according to, “the order it was submitted in a particular session.” (lines 12–13) So the 1 means that it was submitted first in a particular session. Choice (B) is the correct answer.
- 2. C** This is a tricky question. The major clue is that only three entities are mentioned in the passage: the House of Representatives, the Senate, and the President. You should suspect then that the answer will be the Senate and the President since those are the only other two entities mentioned in the passage. You can get confirmation for this hunch in the sentence that says “Bills are presented to the President for action when approved in identical form by both the House of Representatives and the Senate.” Bills must pass both houses, so if the bills originate in the house, they have to go to the Senate before reaching the President. The answer is (C).
- 3. A** The paragraph is about how Native Americans have “long recognized and celebrated the connectedness among all natural things.” The medicine wheel illustrates this point because it emphasizes the connectedness of the four basic elements. So (A) is the best choice.
- 4. E** Remember the Native American view stated in the passage is that all natural things are connected; so we should expect that the scenario will demonstrate this belief. (A) is specifically opposed to that. (C) is also, to a lesser degree. (B) is neutral toward the Native American idea—it neither contradicts it nor realizes it. (D) and (E) are in accord with the Native American view because they recognize the connectedness of an organism and its habitat. However, (D) mention studying a specific

organism in its habitat, while (E) mentions studying a habitat as a whole. So, (E) is broader and, in this case, broader is better. The best answer is (E).

5. C Does the author portray Copland's music in a very negative or very positive light? Neither, so (A) and (E) are out. The author actually just describes the reactions of others to Copland's music and interjects little opinion of his or her own. That eliminates (D). Then again, the author is not *clinically objective* in tone (just think, the passage does not sound like a science passage). That makes (C) the best choice.
6. C The virtuoso passages are passages only a virtuoso could play—essentially, difficult. Eliminate (E). There is no negative judgment of that quality in the passage. That eliminates all but (C), which is the answer.
7. C The different fates were that the *Piano Variation* was known by many pianists, but played by few in concert, and the *Symphonic Ode* was largely unknown because it was too difficult. Choice (C) says as much, and so is the answer.
8. A In the passage, Koussevitzky is first mentioned in connection to the difficulty of playing the *Symphonic Ode*. The passage tells you that even he, a “champion” of Copland's music, did not conduct the piece until it had been simplified. Choice (A) correctly points this out. Don't be tricked by the difficult name into answering that he was European.
9. C The second paragraph begins, “Perhaps as a reaction to the performance problems of the *Symphonic Ode*, Copland's next two orchestral works deal in shorter units of time.” So the author thinks that the pieces immediately subsequent to the *Symphonic Ode* were made shorter because the Ode was not being performed. Choice (C) says the same. (B) is tempting but the passage explicitly states that it was the length and not the complexity that Copland adjusted in the subsequent pieces.
10. E This sentence is essentially saying that, although brief, these works were also very difficult to perform. The answer is (E). This is essentially a vocabulary question, asking you to define “agile.”
11. C First off, what does the passage state about Copland's views of the Americas and music? It says that Copland, “envisioned ‘American music’ as being music of the Americas.” In other words, he thought they were related, or should be. (A), (B), and (E) run contrary to this meaning. (D) is irrelevant. The answer is (C).

- 12. D** The Mexican material is more accessible to audiences. The opposite of accessible is inaccessible. (D) should look good to you right away. Don't get confused by (C). The emphasis in the sentence is on audiences, not musicians.
- 13. C** You can eliminate (B) because it is too specific. You can eliminate (D) because the author never talks about eating or brushing teeth or other daily activities. (E) is also too specific. (A) is really off in emphasis; the author focuses on describing the Earth's appearance more than the trajectory of the Space Station. The answer is (C). It's also a good answer because it captures a little bit of the tone of the piece; the author seems to write the passage for an average person experiencing curiosity about seeing the Earth from space.
- 14. E** The second half of the paragraph contrasts seeing the whole Earth to seeing just a limited part of it. But the emphasis is on seeing the whole Earth, because we've all seen limited parts of it. The answer is (E).
- 15. B** Here you have to be careful because two different window views are discussed in the passage. The downward-facing window is discussed in the second half of the second paragraph. And there the author compares the view to looking at a big blue beach ball up-close, choice (B).
- 16. B** This is where that second window view comes in. The author first discusses the downward-facing window and then contrasts it with looking through a sideward-facing window in the third paragraph. (B) is the answer.
- 17. B** The passage discusses the "faint glow" in the last sentence of the third paragraph. There, he attributes it to the outer rim of the atmosphere. (B) says the same thing. (A) mentions the atmosphere, but it designates the wrong part of the atmosphere.
- 18. B** Before the thought exercise is given the author states that, "a good way to imagine our view is to stand up and look down at your feet." In "imagining the view" through the thought exercise the reader gets a definite idea of the proportions of things within the space stations view (e.g. where San Francisco is in relation to Denver). Choice (B) says as much, and so is the best answer. Choice (C) is a tempting answer, because it is the idea with which the paragraph begins, but it ends up being too narrow a description of the thought exercise.

19. **D** You may be tempted to answer (A), because the passage can be confusing. But it's not dry or scientific, so "technical" just isn't a good word for it. Choice (B) doesn't capture its informality. Choice (E) is too extreme—as far as poetic descriptions of the planet go, this one doesn't even rate. That leaves (C) and (D). Choice (C) isn't quite right, either, because it's not irreverent, it's just casual. Choice (D) best captures that sense.
20. **D** You don't know a lot about what the astronauts do from the passage, so you'll have to dig this answer up. Choice (A) seems silly, and would really be a disrespectful thing to say about the author. The SAT won't do that. So eliminate (A). There's no reference to gravity in the passage, so eliminate (B). There's no real reference to physical activity, so (C) seems wrong. You are left with (D) and (E). The astronaut uses a lot of numbers, and throws them around as though they were quite easy. (D) seems like a reasonable answer. There's no reference in the passage to *communication procedures*, which means you can eliminate (E) even though it's sort of a tempting answer.

Section 2

1. **C** This is the first question, so it should be one of the easiest, if not the easiest, questions in the section. For this reason, you don't have to expect anything too tricky about this problem. Substitute $x = -y$ into the first equation and solve for x :

$$\begin{aligned}x + 4y &= 3 \\-y + 4y &= 3 \\3y &= 3 \\\frac{3y}{3} &= \frac{3}{3} \\y &= 1\end{aligned}$$

(C) is the answer.

2. **B** There are two main parts to this problem:
1. the use of the variable d , and
 2. the change of units from hours to minutes.

Start with the variable since d is half as much as $2d$, it should take him half the amount of time, or 1.5 hours. One hour is 60 minutes, and half an hour is 30 minutes, so 1.5 hours is 90 minutes. That's choice (B).

3. A There is more than one way to solve this problem, but all paths involve manipulating the equation. You can solve for f in the first equation, and then plug that value into the second equation. You could also just leave the $3f$ as is, and monkey with the formula this way:

$$\begin{aligned}3f + 15 &= 27 \\3f + 15 - 15 &= 27 - 15 \\3f &= 12 \\3f - 6 &= 12 - 6 \\3f - 6 &= 6\end{aligned}$$

Whichever path you take, if you manipulate the equation correctly you'll get choice (A) as your answer.

4. A The first thing to notice is that this triangle is a 30-60-90 triangle, one of the SAT's favorite triangles. Since you can read off the relationships between different sides of a 30-60-90 triangle, it can be readily seen that the $x + y$ side is half the length of the hypotenuse (which is 14). Half of 14 is 7, so (A) is the answer.
5. D Translating the English into algebra is the key to all word problems.

Since the snack costs twenty cents less than the drink, you can write down $d - 20 = s$. Since a snack and drink together costs \$1.30, you also know that $s + d = 130$. You have two equations and two variables. Substitute the first equation into the second and then solve:

$$\begin{aligned}s + d &= 130 \\(d - 20) + d &= 130 \\2d - 20 &= 130 \\2d - 20 + 20 &= 130 + 20 \\2d &= 150 \\\frac{2d}{2} &= \frac{150}{2} \\d &= 75\end{aligned}$$

A drink costs 75 cents (\$0.75), so (D) is the answer.

Tip

For problems dealing with units of money, always decide whether you want to work in dollars or cents. If the amount of money is great, using dollars is typically the best way to go. On this problem, converting to cents might work better since you won't have to deal with any decimals.

6. **D** This problem looks really complicated, but don't let that ruffle your test feathers. With function problems, just plug in whatever the problem tells you to plug into the equation. Be a machine! Here, you are considering when $x = 2$, so $f(2x)$ is the same thing as $f(4)$. (Of course, the question could have just said $x = 4$, but that would have been too easy).

Now just replace every x in the problem with a 4:

$$f(x) = x + x^x$$

$$f(4) = 4 + 4^4$$

$$f(4) = 4 + 256$$

$$f(4) = 260$$

Your answer is (D).

7. **D** This one looks strange, and it is as straightforward to solve as it appears. If you only consider $\sqrt{x^2}$ to be x , then you only get the extraneous solution, and not the correct one. You start by squaring both sides and then factoring.

$$x^2 = 4x^2 + 12x + 9$$

$$0 = 3x^2 + 12x + 9$$

$$0 = 3(x^2 + 4x + 3)$$

$$0 = x^2 + 4x + 3$$

$$0 = (x + 3)(x + 1)$$

$$x = -3 \text{ or } x = -1$$

Checking both solutions in the original equation, you see that only $x = -1$ works. This is choice (D).

8. **E** If $|x + 1| > |y|$, what do you know about x and y ? Not much actually. x could be -10 and y could be 5 , and the inequality would be true. But x could also be $10,000$ and y could be $9,998$, and the inequality would still be true. This means you cannot nail down the relationship between x and y , so (E) is the answer.

9. A This question is almost all Math Speak, but hopefully you are getting better at this language. The whole thing sets up an equation. “Percent” means “divide by 100,” and “is the same value” works the same as an equal sign. “What number” is Math Speak for “place a variable here.” Here’s the translation:

“75 percent of 104 is the same value as 60 percent of what number”

$$\left(\frac{75}{100}\right)(104) = \left(\frac{60}{100}\right)n$$

$$(0.75)(104) = 0.6n$$

$$78 = 0.6n$$

$$\frac{78}{0.6} = \frac{0.6n}{0.6}$$

$$130 = n$$

Choice (A) is the answer.

Note

The percentages were rewritten as decimals instead of fractions to make it easier to use your calculator. Dividing 78 by 0.6 is not something most people can do easily, but for a calculator, it’s a cinch.

10. D Equations of lines can be put into the $y = mx + b$ form, and then the y -intercept, b , can be read off.

$$3y - x = 12$$

$$3y - x + x = 12 + x$$

$$3y = x + 12$$

$$\frac{3y}{3} = \frac{x}{3} + \frac{12}{3}$$

$$y = \frac{x}{3} + 4$$

If 4 is the y -intercept, and twice this number is 8, choice (D).

11. C

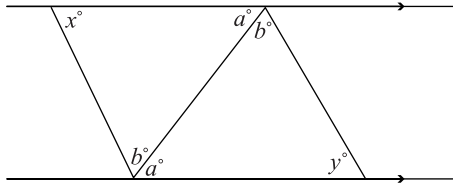

As you can see from this figure $a = a$, and $b = b$ because alternate interior angles are congruent. If two angles of a triangle are congruent to two angles of another triangle, what can you deduce about the relationship between the third angles? The third angles must also be congruent. If you don't see this, pick values for a and b and remember that the sum of the measures of the interior angles of a triangle is 180. Choice (C) is the answer.

12. D These next three problems test your ability to deal with unfamiliar symbols. Recall that you will be told everything that you need to know about the new symbol. Carefully read the instructions and don't get rattled; everything you need to know about the new symbol will be handed to you on a platter.

In the subtraction problem, convert each term one at a time:

$$\in 2323 = 3322 \text{ and } \in 2321 = 1322$$

(It's helpful if you write out the middle unchanging middle digits first, and then write the first and last digits.)

$$\text{So } \in 2323 - \in 2321 = 3322 - 1322 = 2000, \text{ choice (D).}$$

13. A You know that A is a two-digit number between 10 and 20, which narrows the field of possible answers to 11, 12, 13, 14, 15, 16, 17, 18, and 19. This may seem like a lot, but the second part of the problem will narrow things down. The equation $(\in A)^2 = \in(A^2)$ looks confusing, but the key word is "equation." The two values are equal, even though you've flipped the first and last digits. Flipping 19 makes 91, which is quite a difference, and it's highly unlikely that $19^2 = 91^2$.

At this point, you might suspect that 11 was the answer because reversing the digits does not change the value of the number. That is a good suspicion, and if you see it, you can easily read off that (A) is the answer. If you did not have that suspicion, just dive into the problem trying different choices.

14. E Since each variable is a digit and the inequality is true, plug in some numbers to try to make the smallest difference possible:

$$\begin{aligned} A &> B > C > D > E \\ 5 &> 4 > 3 > 2 > 1 \end{aligned}$$

Now look at the subtraction problem and plug in the numbers above:

$$ABCD - \epsilon(ABCD) = 5432 - 2435 = 2977$$

The difference is greater than one thousand, so choice (E) is the answer.

Note

There is a theoretical path that leads to the same answer on this problem, but when dealing with weird symbols problems the theoretical path is usually not the best one to take. As you can see, generating some numbers and then placing them into the equation works well and didn't take too long.

15. C There's no answer choice that says, "It cannot be determined," so you have to realize that there is a way to determine the area of the circle. Since the area formula for a circle is $A = \pi r^2$ this means there has to be a way to find the radius of the circle, which in this case is line segment RS .

The two statements underneath the drawing give you the tools you need. If "line q is tangent to circle R ," then angle RST is a right angle.

And if $RS = \frac{RT}{3}$, then you can determine the value of RS since the problem gives you the length of \overline{RT} as 18. For line segment RS , the radius will be 6, since $\frac{18}{3} = 6$. If you place this value of the radius into the area formula for a circle, you'll find answer (C) at the end.

$$\begin{aligned} A &= \pi r^2 \\ A &= \pi 6^2 \\ A &= 36\pi \end{aligned}$$

16. E All of the answer choices mention August and September total sales, so the first step in this problem is to figure out what these values are. In the table, August has two squares (1,000 each) and three triangles (50 returns each), so total August sales are:

$$2(1,000) - 3(50) = 2000 - 150 = 1,850$$

Doing the same box-and-triangle conversion, you should find that September total sales were 1950. Therefore, there were 100 more sales in September than in August. This lets you cross out (B) and (D), because they have September total sales as being *less* than August total sales.

The final three answers all have different percentages. The difference in monthly sales is 100 ($1950 - 1850$), so what percent of 1,850 is 100?

$$\begin{aligned} \left(\frac{n}{100}\right)1850 &= 100 \\ (100)\left(\frac{n}{100}\right)1850 &= 100(100) \\ 1850n &= 10000 \\ \frac{1850n}{1850} &= \frac{10000}{1850} \\ n &= 5.4 \end{aligned}$$

100 is 5.4 percent of 1850, which means that September total sales were 5.4 percent greater than August total sales. (E) says the same and is the correct answer.

17. C You cannot solve this problem unless you do some creative line drawing.

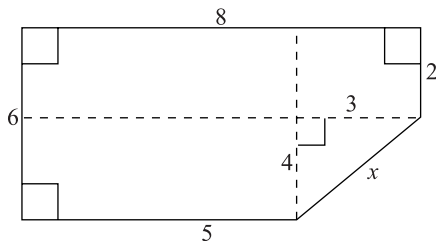

To find the unknown lengths, you have to subtract known values of opposites. Take the top and bottom sides, for instance. The larger top side is 8, and the lower part is 5, so the difference must be 3. A dashed line shows this value. Subtracting the right side (length 2) from the left side (length 6), you find another dashed line that has a value of 4.

From this sketch you can see that x is the hypotenuse of a 3-4-5 triangle, and so is equal to 5. This means the perimeter is 26, (C).

- 18. A** Unpack the tangle of terms, and you'll find the answer. You are looking for two prime numbers that:

1. When you subtract them you get 21.
2. When you multiply them you get one of the answer choices.

It might not sound like enough information to find the answer, but it is. None of the answer choices are very great, so one or both of the prime numbers must be less than ten. If the two primes were greater, their product would not be as small as the answer choices. The difference between the two primes is 21, which means that one of the prime numbers must be small. Good candidates for the lesser prime are 2, 3, or 5.

Prime numbers starting in the 20s are 23, 29, 31, and 37. Use a little trial and error, and you'll realize that the difference between 23 and 2 is 21. Those are the two primes. What is 2 times 23? The answer is 46, choice (A).

- 19. B** First, it always helps to draw a quick sketch of the scenario to get a better grasp on what is being asked.

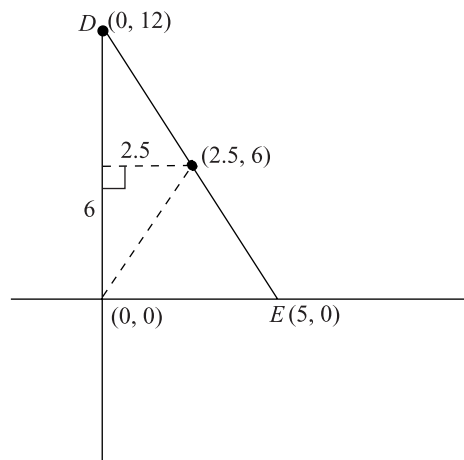

The first thing to determine is the midpoint of \overline{DE} , which you can do by using the midpoint formula:

$$\left(\frac{x_1 + x_2}{2}, \frac{y_1 + y_2}{2} \right) = \left(\frac{0 + 5}{2}, \frac{12 + 0}{2} \right) = \left(\frac{5}{2}, \frac{12}{2} \right) = (2.5, 6)$$

You can keep the x -value as a fraction if you like, but converting it to 2.5 will make it easier to punch into your calculator.

Looking at the dashed lines, you can see a right triangle with its hypotenuse from the origin to the midpoint of DE . It has sides of 2.5 and 6. Placing those values into the Pythagorean theorem yields:

$$\begin{aligned} a^2 + b^2 &= c^2 \\ 2.5^2 + 6^2 &= c^2 \\ 6.25 + 36 &= c^2 \\ 42.25 &= c^2 \\ \sqrt{42.25} &= \sqrt{c} \\ 6.5 &= c \end{aligned}$$

It's choice (B).

- 20. A** It's a big equation, but in the end it's just that: an equation. You have to pull out two different techniques—FOIL and PEMDAS—to solve it, but so long as you write out your work carefully, you will reach the right answer.

$$\begin{aligned} -b^2 &= (b - 7)(b + 3) - (2b + 2)(b + 5) \\ -b^2 &= (b^2 + 3b - 7b - 21) - (2b^2 + 10b + 2b + 10) \\ -b^2 &= (b^2 - 4b - 21) - (2b^2 + 12b + 10) \\ -b^2 &= b^2 - 4b - 21 - 2b^2 - 12b - 10 \\ -b^2 &= -b^2 - 16b - 31 \\ -b^2 + b^2 &= -b^2 + b^2 - 16b - 31 \\ 0 &= -16b - 31 \\ 0 + 16b &= -16b + 16b - 31 \\ 16b &= -31 \\ \frac{16b}{16} &= \frac{-31}{16} \\ b &= -\frac{31}{16} = -1\frac{15}{16} \end{aligned}$$

Choice (A) is your answer.

- 21. A** There's no table given for this question, so it's up to you to create one. In this respect it's like a diagram without a diagram given: You could conceivably answer it without the visual aids, but it's much easier with them.

For the table, start with the years:

1950 1960 1970 1980 1990 2000

Now place the number of people in Cree County in 1950 in the appropriate place, and then start multiplying by three.

1950	1960	1970	1980	1990	2000
1000	3000	9000	27000		

In the 1980s, the population fell by one-half, so divide 27,000 by 2. Then go back to multiplying by 3.

1950	1960	1970	1980	1990	2000
1000	3000	9000	27000	13,500	40,500

Your answer is choice (A).

Section 3

1. **A** Something that can be counted requires “fewer” rather than “less.” The answer is (A).
2. **B** In *for Ada and I*, *I* is used here as the object of a preposition (*for*). That should never be. *Me* is the object of a preposition, or a direct or indirect object. The answer is (B).
3. **B** Is the subject in this sentence singular or plural? *Team* is singular. Is the verb singular or plural? *Compete* is plural. The clause *which is comprised of four cyclists* obscures the subject-verb disagreement, but it is still there. (B) is the answer.
4. **E** Did you hear any mistakes in this sentence? Hopefully you didn’t because there are not any. (E) is the answer.
5. **A** If you know that Louis and Clark were nineteenth-century explorers, the verb *have surveyed* might sound strange even before you read the rest of the sentence. If not, *were well prepared* suggests that the first exploration happened prior to an event which is, itself, in the past. The first verb should be *had surveyed*, and the answer is (A).
6. **D** There is a parallel structure problem here. *Focus*, a verb, should be paired with *follow up*, a verb, not *follow-up*, which is a noun. The answer is (D).
7. **C** Nothing in this sentence sounds wrong, but (E) is not the answer. Here’s why, to whom does the *its* refer? It is not clear if it refers to the Ottoman or Austrian Empire. An ambiguous pronoun reference is an error, and so (C) is the answer.

8. **A** What is the subject, *census* (singular) or *statistics* (plural)? *Statistics*. *Census* is used as an adjective. The plural subject means you would need a plural verb, *were*. The answer is (A).
9. **B** *Scarcely no one* is a double negative. It should be *scarcely anyone*. (B) is the answer.
10. **D** This is a tricky question because the error arises with the implied part of the sentence. The full sentence with the implied part written out explicitly reads, “Even though he had the title of Vice-President of Operations, his duties and responsibilities were not much greater than a midlevel manager’s duties and responsibilities.” The short version should still say *manager’s*. The answer is (D).
11. **D** After both, you especially need parallel structure. It should read *more accessible and more understandable*. The other answers only confuse the original. The answer is (D).
12. **D** The initial modifier should put you on the lookout for an incorrect noun, or reference to the “thing” that is being modified. You should examine the noun that directly follows the modifier carefully. Does the modifier modify the noun that follows it? Nope. The poet, Gerard Manley Hopkins, not his poems, is what is being modified here. The possessive form (*Hopkins’s*) and the noun *poems* messes things up in the original and answer choices (A), (B), and (C). To make it work, you need to get rid of the possessive on the author’s name. Only (D) and (E) do that. (E) makes an unnecessary change to the verb. The better answer is (D).
13. **E** The original underlined phrase is not glaringly obtuse or a grammatical disaster, but it is a little wordy. Also, *this includes the Human Rights Commission* is a complete sentence, so it would need to be attached with a semicolon. Only (E) addresses both problems without creating others.
14. **C** The most blatant mistake here is that, again, the clause that follows a comma is technically a complete sentence. The best way to approach this question is to read all the way through each of the answers to see if they contain problems. (B) has tense problems. (D) also has two complete sentences attached by a comma (this is called a comma splice). (E) just doesn’t work. The answer is (C).

15. **B** The underlined portion of the sentence reads awkwardly for two reasons. First, it includes the phrase *her plans of*, which is redundant because the list is a list of her plans. Second, the preceding plans in the list are given in infinitive form (i.e. *to refinance*), but the last plan of action is not in infinitive form. Any answer choice that deals with these two issues will be the best choice. (B) is that answer choice.
16. **B** You know the correct answer won't be a complete sentence, because it is attached by a comma to the main clause. Eliminate (E). You will also want to cut down on wordiness, rather than add to it. Eliminate (A) and (C). *Which* suggests that the clause modifies a noun that comes just before it. That isn't the case. The answer is (B).
17. **C** Again, you want to move toward parallel structure as much as possible. You don't want nouns in one part of the list and verbs in another, as you have now. Change the noun *tolerance* to a verb, *tolerate*. You can narrow the field to (C) and (E). (E) is wrong because you don't use a comma in a two-items list.
18. **D** Guess what? Parallel structure again. *To commit a crime* needs to be followed by *(to) conceal it*. That leaves (D), without you even having to know that *among* suggests more than two people, whereas *between* suggests two.
19. **C** Here's the test writers' other favorite trick: "not only" with "but also." Only (C) and (E) use this construction. (E) makes the tenses unnecessarily complex. The answer is (C).
20. **D** The sentence as it stands is muddy and unnecessarily wordy. These are things to be avoided in good writing. "If" should be followed by a "then" clause. What follows here doesn't fit that logical pattern. So *if* is out. That leaves (D) and (E). (D) gets rid of the repetitive and vague *it* in the second part of the sentence. Good. The answer is (D).
21. **D** The original version should wave a red flag at you that it is repetitive and cumbersome and will need to be changed. (B) is even more vague and wordy than the original, despite being a single sentence. (C) is weak because it begins the essay with the word *it*, which is never a strong opener. (E) is suspect because the essay is about the word *modern* not *modernity*. (Yes, *modernity* is later introduced, but that does not change the point that the essay is about the word *modern*.) (E) is also unnecessarily wordy. That leaves (D).

22. **B** Descartes is the thing that will link the two sentences. He is the subject of the first and the object of the second. This is a prime example of when to use *whom*. (B) is better than (C) and the others are longer than the original, not shorter. (B) is the answer.
23. **E** What is the logical connection between the opinions of academics other than philosophers and the opinions of historians in particular? The latter is an example of the former. The answer is (E).
24. **B** The original sentence is clunky because it has both *beginning of modernity* and *beginning of modern times*. You will want to replace the second with *it*. That leaves (B) and possibly (E). (E) adds unhelpful extra verbiage in other places, so (B) is the best answer.
25. **E** Anything separated by commas should be detachable from the rest of the sentence. Remove the phrase between commas and you get *Most of us. . . we are thinking*. Bad. Most of us *think*. (E) is the only answer that addresses that problem correctly. (B) actually changes the sense by eliminating the subject of “think” so that it becomes a command.
26. **B** Choices (C) and (E) have an imprecise and unclear *-ing* verb, so eliminate them. (D) is just a wordier alternative to (B), so eliminate it. (B) is so straightforward and clear that it is better than the original. The answer is (B).
27. **E** The passage is talking about the 1920s. Be as specific as possible, without being wordy as in (C) and (D). The answer is (E).
28. **C** The only punctuation marks that are possible here are parentheses, a semicolon or a colon. The second sentence gives more specific information to elaborate on the first sentence, so a colon is better than a semicolon or parentheses. The answer is (C).
29. **D** What’s wrong with the transition in the original? Is it a logical problem or a grammatical problem? It sounds weird and wordy, so it’s a grammatical problem. The sense is logical, so keep it. Eliminate (A); it changes the sense. Which of the answers simplifies and clarifies the grammar? The answer is (D).
30. **A** Eliminate (D) because it’s grammatically incorrect. Eliminate (C) because it really doesn’t go with the ideas in the passage. If you look back at the passage, you’ll see that the last sentence is not about Macy’s but Bloomingdales. (E) would be out of place, so eliminate it. You’re left with (A) and (B). While (B) would be an adequate conclusion to the third paragraph, only (A) reflects back over the entire passage. The best answer is (A).

Section 4

- 1. D** Jerome does not indulge much. He is an *ascetic*, (D). A *teetotaler*, (B), is someone who does not consume alcohol. A *gourmand*, (C), is someone who indulges a great deal in fine food. Neither (A) nor (E) have anything to do with indulgence.
- 2. A** Begin with the first blank, since you know that it must be something negative since protests were planned. (B) and (D) are not negative, so eliminate them. Going to the second blank, *organized* fits well, while *negotiated* and *theorized* do not (you don't *theorize* about a protest event). This makes (A) the best answer.
- 3. B** We know the first word will be negative, since it engendered criticism. All of the words are negative, so you can't eliminate anything yet. But what would a politician be if he "seized a ceremony" having to do with a "girl's tragic death to speak out against his opponent"? Not militaristic, or unreceptive, certainly not passive or defeatist. The answer is (B).
- 4. E** All of the options in this question have a first word that could be something one software did to another. For the second word, all the choices, except (D), are things a user could likely do to software. *Preclude*, (A), means make something impossible, but the "prior version" clearly isn't impossible so eliminate (A). If the older version is *outdone*, you don't want to *implement*, or use, it. Eliminate (B). If something is *infected*, you don't want to *disregard* it, so eliminate (C). The answer is (E). *Supersede* means replace by being better, which would mean you could throw out, or *discard*, the now useless thing.
- 5. B** Let's start with the first blank since it has to be paired with *long*. Which of the first answer choices pairs well with *long*? Only *storied*, *exemplary*, and *reputable* do (the others either are awkward or don't fit with the meaning of the sentence). Plug in the second answer choices of (A), (B), and (E) into the sentence. Can poetry initiate the dignity of humanity? No. Eliminate (A). Can it articulate, or express? Definitely. Choice (B) sounds too good to pass up.
- 6. C** You should have a good sense of what kind of word goes in each blank because each blank has a pair. The second blank has a more obvious pair, so start with it. Which of the second answer choices goes with *speedy*? (A) and (C) are the best candidates. On the first blank, does *intricate* and *laborious* or *fragile* and *laborious* sound better? *Intricate* does because it provides a better contrast with the second half of the sentence. (Also, it is strange to speak of a surgery being *fragile*; someone in surgery might be in *fragile* health, but the surgery itself would not be *fragile*.) (C) is the answer.

7. **A** *Despite* at the beginning of the sentence is the main clue to unlocking the blank. You need one positive word and one negative word. Eliminate (B) and (C). Now what can clans do to each other? *Assist*, possibly *discount*. A problem is ameliorated, not a person or group of people. (A) is the better answer, especially since “feud” and “clan” are both words that seem to refer to the past.
8. **B** From the structure of the sentence, we can see that the word in the blank goes along with *humor* and *merriment*. Which of the answer choices fits with these two positive words? Only (B), *mirth*, does. (*Irony*, *history*, and *mystery*, are at best neutral terms in this context, not positive.)
9. **A** The Latin makes this sentence complicated. You can combat this by replacing the Latin words with the letters (A) and (B) in your head (i.e. although (A) has more subspecies than (B) . . .). The *although* is the key to the logic of the sentence structure. *Although* (A) has more subspecies than (B), (B) has greater numbers. (A) and (E) match this pre-guess for the first blank. (E) isn’t really logical (how can a region be ominous?), so the answer is (A).
10. **D** Looking at the first blank, (B) and (E) can be eliminated because both are not conventional English. That leaves (A), (C), and (D). (A) is suspect, though, because *progression* is an odd word choice for the context. (C) is illogical. (D) is a best choice because it flows well in both blanks and because development is already a word you associate with “pregnancy” and “fetus.”
11. **C** The word, *Though*, tells you that the ideals and the practices of the organization are at odds. So if the ideals are *outward-focused* then the practice must be inward-focused. Which of the answer choices matches this pre-guess? Only (C), *insular* (isolated, circumscribed), does. Hermetic means tightly sealed. It’s not too far off in meaning, but it doesn’t refer to group behavior.
12. **B** On the first blank we know that the word goes with *base*, and we know that the prosecuting attorney is probably not saying nice things about the defendant. (A) and (B) fit this (*motley* doesn’t; even though it has a negative connotation, it means a random or ungainly assortment). This leaves *misunderstanding* the testimonials or *misconstruing* the testimonials, for the second blank. The latter is a better choice since the prosecuting attorney is more likely to be making the defendant sound bad on purpose than by mistake.

13. **B** This sentence is either really positive or really negative about the new drug regime. It is more likely positive since a new drug wouldn't come out if it was known to be really negative. So your inclination should be that the blank is very positive. Only (B) fits this, and it fits well. If you have extra time, you can check to see if there is a really negative response that might fit better. *Bane* could work in terms of meaning, but it doesn't work syntactically.
14. **C** The blanks in this sentence are a little more complicated because they must be considered together. The first blank is negative and the second blank is even more negative (in the same way, or to a greater degree). The second blank isn't negative in (A) and (D), so they are not it. That leaves (B), (C), and (E). Of the three, (C) is the best since *self-centered* and *egocentric* are synonyms and *solipsism* is a more negative form of both words. You might be tempted to go with (B) because you don't know what solipsistic means, but you can eliminate it because *ill-tempered* has little to do with *self-centered*.
15. **B** What is a good pre-guess for the blank? Really hectic (that is, opposite of *alleviating demands upon our time*). Only (B) matches this pre-guess, and it fits in the flow of the sentence.
16. **A** This is a global question since it cannot be answered by looking at one specific place in the text but has to be weighed considering the passage as a whole. Ask yourself, does the author present Dr. Rael positively or negatively, sympathetically or unsympathetically? The article describes Dr. Rael's career, generally in positive terms, and no criticisms of Dr. Rael's work is discussed. So the answer should be positive. That eliminates (C)—(E). (B) might seem appealing, but realize that an article can *engage* a person's work without being positive about that work. Also the passage more tells about Dr. Rael's work than *engages* it. So (A) is the best choice.
17. **C** Again this is a global question. To rephrase the question, what is the passage about? It tells the story of Dr. Rael's life with specific emphasis on his professional career. Choice (C) captures this. You might have been attracted by (E), but remember the passage only discusses the Rael family when it contributes to the story of Dr. Rael.
18. **B** You can answer this either as a detail question or as a global question; you will get the answer more quickly if you answer it as a detail question. You can find in paragraph 3 that "José Ignacio had the foresight to recognize the changes that were coming with the increasing Americanization of New Mexico and realized that a fluent knowledge

of English. . . would be necessary.” Choices (B) and (D) seem to echo this sentence. But the passage does not go on to say that Dr. Rael did not learn English. The answer is (B). If you answer it as a global question, use the process of elimination. The passage doesn’t mention job discrimination. The passage refers to Rael studying far from his family, but doesn’t mention that problem in regard to teaching. It strongly suggests that Rael was successful in American schools with English names, so eliminate (D). The passage doesn’t specify what Rael studied before his Ph.D. Choices (C) and (E) are hard to eliminate, but an overall view of the passage should convey that the folklore was precious and disappearing.

19. **E** Relinquished means he gave something up, but the passage does not state that Rael was *relieved* to give up his family duties. Eliminate (D). There is no mention of sibling rivalry, so you can eliminate (A). The passage doesn’t say if the family was wealthy or simply OK, so (B) is out. It certainly doesn’t say Rael had tried to be a rancher, choice (C). That leaves (E).
20. **E** This question is similar to question 18, but it is definitely a global question. The basic gist of the passage is that Rael’s work was important. He collected Spanish-language folklore and studied the particular Spanish used in the area. The answer is (E).
21. **C** Someone you study under is your mentor. This is a vocabulary question. The answer is (C).
22. **B** Corpus refers to a body of work. The only answer choice that reflects the idea of more than one book is (B).
23. **B** Looking over the choices, there is no reference to Dr. Rael enjoying working on the ranch (or using his scholarly pursuits to avoid it, which would already be using logic too strained for the SAT). The passage does mention his love of *Pastores*. Just after the mention of *Pastores*, the passage says this influenced his later work. Bingo. The answer is (B).
24. **A** This is a tough one. But “diffusion of motifs” seems to be related to the number of variants of a particular story. That eliminates (C) and (E). The passage goes on to emphasize how many variants there were, suggesting that the answer will emphasize difference more than sameness. Eliminate (B) and (D). The answer is (A).
25. **B** If you do not know the definition of *provenance* you are not lost on this one. Replace it with each of the answer choices and see which one makes the most sense. If you do know the definition of *provenance* (origin), then (B) pops out as the answer.

26. **D** The end of the seventh paragraph states, “But inevitably the historic-geographic approach led more to collection building than to analysis.” This is the most critical sentence in the passage. The answer (D) includes the word “analysis” and is a fair paraphrase of this sentence. The answer is (D).
27. **B** This one is also hard. First of all, do you know what *formidable* and *quixotic* mean? Impressive, difficult, and errant—which is to say, traveling a lot. This comes from Don Quixote, who traveled a lot. He was also a little crazy, which is why the test writers try to trick you with (A) and (C). But these don’t apply to Dr. Rael. Remember, the overall tone is “laudatory.” (E) tries to trick you by getting you to admit that you were confused at this point in the passage. Admitting you don’t know will never be the answer on the SAT. The answer is (B).

Section 5

1. **A** The wrinkle in this word problem is correctly translating what a “quarter” of the factory’s capacity means. A quarter is one-fourth of something, so a quarter of full capacity—200 sheets of paper per second—is one-fourth of 200, or 50. If a quarter-capacity is 50 sheets per second, in 12 seconds the factory would produce 600 sheets since $50 \times 12 = 600$. Choice (A) is what’s going on.
2. **E** This is a straightforward variable/equation substitution problem. If $Z = 3$ and $Z = \frac{2x}{5}$, then you substitute the value of 3 for Z in the second equation to get:

$$Z = \frac{2x}{5}$$

$$3 = \frac{2x}{5}$$

$$(5)3 = \frac{2x}{5}(5)$$

$$15 = 2x$$

$$\frac{15}{2} = \frac{2x}{2}$$

$$\frac{15}{2} = x$$

(E) is the answer.

3. A There are two prime ways to approach this problem. You can do a factor tree for both numbers, find the common factors, and then look down the answer list for the greatest one. If you don't know what a "factor tree" is, you could go through the answer choices one by one to see which is the greatest that divides 32 and 42. Start with choice (E), since it's the greatest number, and if it works, it's the answer. 12 doesn't work, so try the next greatest one, 8, choice (D). Eight doesn't work, and neither does 6 or 3. This leaves (A).

4. B If you understand the idea of slope, the answer will fall into your lap. If you have trouble with this problem, review pages 350–352 in the Math section to make sure you are perfectly comfortable with slope and linear equations in the form $y = mx + b$.

Viewed from left to right, the line descends, which means the slope is negative.

That eliminates choices (C), (D), and (E). A slope is "rise over run," meaning you look at the change in y -values as the numerator of the fraction, while the change in x -values is the denominator. The line drops two points along the y -axis for every three points it moves over on the x -axis, so the slope is $-\frac{2}{3}$, choice (B).

5. E You need to know the total number of students in each grade to answer this question. The table tells you there are 32 in the 4th grade, so you only need to determine the total in the 3rd grade. There are 16 boys and 14 girls in the 3rd grade, which makes 30 total. The overall total is 32 plus 30, which is 62, choice (E).

Note

The table is incomplete, but don't let this worry you. The SAT will always provide the information needed to answer the question, one way or another.

6. D If there are 18 girls in the 4th grade, then there are 14 boys in 4th grade ($32 - 18 = 14$). The table says there are 16 boys in 3rd grade, so there are a total of 30 ($16 + 14 = 30$) in the 3rd and 4th grade. Choice (D) is the answer.

7. **A** Careful here. The problem asks for the value of the exponent, not the simplified expression. Simplifying this expression looks a little wiggly, but you need to be prepared to work with wacky-looking exponents problems like this:

$$\frac{\left(m^{\frac{3}{5}}\right)^{-2}}{m^4} = \frac{1}{m^4 \left(m^{\frac{3}{5}}\right)^2} = \frac{1}{m^4 m^{\frac{6}{5}} m^{\frac{6}{5}}} = \frac{1}{m^{\frac{5+3+3}{4}}} = \frac{1}{m^{\frac{11}{4}}} = m^{-\frac{11}{4}}$$

The exponent is $-\frac{11}{4}$, which is choice (A). If this makes no sense to you, you'll want to review the rules of multiplying and dividing exponents.

8. **C** You can't solve this problem without a little help from the algebraic expressions. You know that the two expressions sum to 90 (because the measures of the interior angles of a triangle sum to 180), but there are two variables and only one equation: $2x + y + 3x - y = 90$ (They equal 90 since the right angle takes up the other 90°.)

If the y variables didn't subtract out when you added the two expressions, you could not solve for x . The whole point to this problem is to brain freeze students who look at it and say, "There are two variables and only one equation. It can't be solved!" If you just write out the equation, you can avoid this type of paralysis. Writing down your work saves the day!

$$\begin{aligned} 2x + y + 3x - y &= 90 \\ 5x &= 90 \\ \frac{5x}{5} &= \frac{90}{5} \\ x &= 18 \end{aligned}$$

(C) is the answer.

- 9. E** For word problems, always translate the English into algebra. Call the distance from Easton to Bethsaida via highway x . Traveling this route is 7 miles longer than going on surface streets, so going via surface streets is $x - 7$. Traveling both routes is 31 miles, which translates to: $x + (x - 7) = 31$. Once you have an equation, you can solve for x :

$$\begin{aligned}x + x - 7 &= 31 \\2x - 7 &= 31 \\2x - 7 + 7 &= 31 + 7 \\2x &= 38 \\\frac{2x}{2} &= \frac{38}{2} \\x &= 9\end{aligned}$$

Here you might to double check that x is the highway route distance and not the surface street distance. Choice (E) is the answer.

- 10. E** A function is undefined at a certain value, if at that value the function does not make any sense. For this function, the most probable way that it could be undefined is if the denominator is zero.

When is the denominator zero? Solve it like a quadratic to see:

$$\begin{aligned}x^2 + 3x - 18 &= 0 \\(x + 6)(x - 3) &= 0\end{aligned}$$

The denominator is zero if x equals -6 or 3 , which is choice (E).

- 11. D** The graph is a parabola, so it will have an x^2 term in it. Sometimes that will help you cross out an answer choice or two, but on this question all answer choices have an x^2 in them. Even so, it was a good technique; it didn't work on this problem, but it will work on others.

The parabola is facing downwards, so the x^2 term must have a negative in front of it. If you don't see why, plug some numbers into $-x^2$. That eliminates (A) and (B).

Our last clue will come from where the figure crosses the y -axis. At this point, x must equal zero, which means that $-x^2$ will also be zero. When x equals zero on the graph, the value of $f(x)$ is -2 . So you are looking for an answer choice that has both $-x^2$ and -2 . Although it's hiding a bit inside some parentheses, (D) is the answer since $-(x^2 + 2) = -x^2 - 2$.

12. **D** With congruent triangles, corresponding angles and sides are congruent. Both are right triangles, so you should smell the Pythagorean theorem wafting about this problem as a method of solving for y .

$$\begin{aligned}a^2 + b^2 &= c^2 \\y^2 + 5^2 &= 10^2 \\y^2 + 25 &= 100 \\y^2 + 25 - 25 &= 100 - 25 \\y^2 &= 75 \\y &= \sqrt{75}\end{aligned}$$

You might also have noticed that both figures are 30-60-90 triangles (you can infer this from the relationship between the hypotenuse and the smallest side of the triangle on the left). This means $y = 5\sqrt{3}$ which brings you once again to $\sqrt{75}$. Either method, choice (D) is correct.

13. **A** Plug in the answer choices and see which ones make the equation true. Many of the numbers repeat and the equation isn't that involved, so this doesn't take as long as you might think. 1 works, but -1 doesn't. If you try all the answer choices, you will see that only 1 works, which makes (A) the answer.
14. **B** There are multiple ways to approach this problem. Possibly the quickest is to count up the multiples of three that are even and 50 or less (if they are even, they will be divisible by 2). This list starts 6, 12, 18, 24 ...

You might stop here and realize that the members of set Z are all multiples of 6. Even if you don't, you'll continue with: 30, 36, 42, and 48. 54 is the next item, but it's too great, so there are eight members of set Z . (B) is the answer.

15. **D** With similar figures, the ratios of each pair of corresponding sides must be equal. The tricky part to this problem is the bent-leg formation of the given figure. The L-shape could roughly be described as, "three squares up, then one to the right." Choice (A) is too thin, i.e. there was no corresponding increase in width even though there is an increase in length. With (B), the small part of L seems to be too big, and with (C) the big part of the L is too large in proportion to the skinny part. Now look at choice (D). The fact that the figure has been rotated makes no difference with similarity. If you draw the following dashed lines on choice (D), you'll see why it's the right answer.

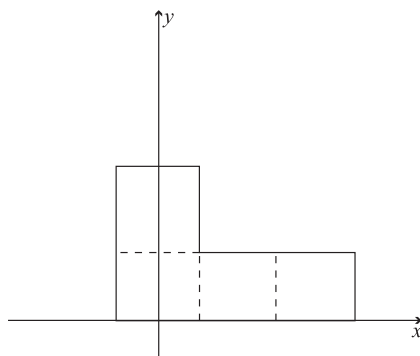

Here you have the same figure, “three squares, then one to the right.” The squares are much larger, but they are in the same corresponding proportion. Choice (D) is correct.

- 16. C** The figure is a square since the side lengths are all equal and all the angles are ninety degrees (if you don't see this, rotate the figure ninety degrees). To find the side length, it's Pythagoras time, but you get a shortcut since you have a special triangle. Each side length is the hypotenuse of a 45-45-90 triangle whose equal sides are of length one. So the hypotenuse/side length of the square is $\sqrt{2}$. Put this into the area of a square formula and you'll find answer (C):

$$A = s^2$$

$$A = (\sqrt{2})^2$$

$$A = 2$$

- 17. B** First, make sure you understand what all those words mean. You have eight numbers that are integers, and are also even, and when you add them up, they sum to 50. Furthermore, only two of the eight integers can be the same value. In other words, there are never three integers that are the same.

To find the greatest possible integer in the set, first make all the other integers as least as possible. The set could be 2, 2, 4, 4, 6, 6, 8, x . This would maximize x . Now solve:

$$2 + 2 + 4 + 4 + 6 + 6 + 8 + x = 50$$

$$32 + x = 50$$

$$32 - 32 + x = 50 - 32$$

$$x = 18$$

This is choice (B).

You can also start with the greatest numerical answer choice and then see if it works, but this will take more time than setting up a formula.

18. E Time to sketch! Here's one where two of the triangle's vertices coincide with two of the square's corners.

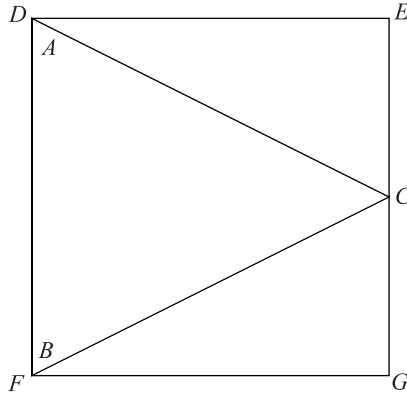

You could also have \overline{AB} run along \overline{DE} . In fact, using \overline{AB} you could put the triangle in the square four different ways (along \overline{DF} , \overline{DE} , \overline{EG} , \overline{GF}). Using \overline{BC} , you could put the triangle in the square four different ways also. The same is true for \overline{AC} . That is a total of 12 different ways that the triangle could be placed in the square such that two angles of the triangle coincided with two corners of the square. It means that (E) is the answer.

19. D You only know the distances between these points. You don't know their orientation in relation to each other. If T is on a line between G and S , then G and T are 4 away from each other ($9 - 5 = 4$). That is the closest that they could be to each other. But if T is on a line with S and G , and S is between G and T , then they are 14 away from each other ($9 + 5 = 14$). This is the farthest that they could be from each other. Therefore I is not possible, but II and III are. Choice (D) is the answer.
20. C If you connect A , B , and C , you have an equilateral triangle with a side length of six. \overline{BD} cuts the triangle into two 30-60-90 triangles. This means that $AD = 3$ —because of the relationship between the sides of a 30-60-90 triangle—and so $\overline{BD} = 3\sqrt{3}$, choice (C).
21. E This problem has many steps, which is why it's number 21. First, ask yourself, "What point on the fan travels the greatest distance through one revolution?" The answer is the point on the corner tip of the fan blade, as it is the farthest from the axis of rotation. In going through one revolution, this point describes a circle because it rotates about a fixed point with a constant radius.

To find out how far this point travels, you need to determine the radius of this circle. This can be done with some help from the triangle shape at the top of the fan. The dashed lines through the two sides show that these sides are congruent. Combine this with the right angle, and you have a 45-45-90 right triangle with two sides of length 4. The hypotenuse of this triangle will be $4\sqrt{2}$, and this length will also be the diameter of the circle.

Therefore, in one rotation that point travels the circumference of the circle it describes:

$$C = \pi d = 4\sqrt{2}\pi$$

But there's more! In 30 seconds, the fan can do 300 revolutions. You know this because the problem states that maximum blade speed is 100 revolutions in 10 seconds, and you can multiply both of these numbers by 3 to get 300 revolutions in 30 seconds. This means that the farthest the point could travel would be:

$$300 \times 4\sqrt{2}\pi = 1200\sqrt{2}\pi$$

Choice (E).

Section 6

- 1. D** The passage reads, "As he matured, however, Remington turned his attention away from illustration, concentrating instead on painting and sculpture." (lines 5–9) So the passage links Remington's concentration upon painting and sculpture as key for his maturation. Eliminate (A). However, the rest of the passage focuses on his paintings, so the answer can't just be sculpture. Eliminate (B). We know he paints nocturnal scenes, so eliminate (E) (this answer isn't specific enough). He is a great artist of the American West, painting before there were any big cities in the West. The passage also implies that he paints natural scenes. The best answer is (D).
- 2. C** Go back to the passage. In the same sentence with *vindicates* is *claim to the status of literature*. This phrase indicates that literature has more status than fiction. You can confirm this hunch in the next sentence, too. It says a *work clearly rises to the auspicious status of literature*. Again, the emphasis is on the loftiness of literature. Choice (C) best captures this sense.

3. C The passage states that the *test of time* method, *by definition excludes contemporary works from consideration*. Choice (C) is a reasonable paraphrase.
4. E There is only one topic that the paragraph mentions twice in relation to the exploration of Mars: detection of life. So this topic is the best candidate for what the paragraph most emphasizes as the motivation for the Mars exploration. The paragraph also concludes with this point. Choice (E) is the answer.
5. B Does the author of Passage 1 criticize the English system? He says it is quirky, but he does not outright criticize it. That eliminates (D) and (E). The author does not strongly praise the system either. That eliminates (A). The author is also not *neutral* toward it (he argues that it is part of the inheritance of the English-speaking world). That eliminates (C). Choice (B), *qualified acceptance*, sounds about right since the author does accept the system but still points out its *quirkiness*.
6. D What is Henry I's role in the passage? Not simply to demonstrate that the monarchy was involved in the development of the English system. Eliminate (B). The story of Henry I is definitely not included to *suggest the practicality of the English system*, since that is contrary to the basic thesis of the passage. Eliminate (E). The basic point of the passage is to argue that the English system developed arbitrarily over time. Choice (D) sounds like a good answer. (A) isn't right, since the author says the anecdote is surprisingly true. Answer (C) is off base, because the passage isn't simply interested in the length, but also the quality, of the English system's history. Choice (D) is correct.
7. C *Earthy* in context must mean something slightly better than ridiculous, because it is used in the discussion of the arbitrary nature of the English system. Choice (C) is the best answer.
8. E Go back to the phrase in the passage. It talks about one system developing in Rome and another in medieval Europe. They reconciled the two by making an estimate of one (the mile) that is an even number of the other (furlongs). Is that synonymous with *determining which one is accurate*? No. Eliminate choice (A). With developing a more accurate system? No. (B) is out. Settling the public's disagreement? Possibly. Hang on to (C). Finding a metric equivalent? Definitely not, so eliminate (D). Ceasing to use two different systems? Definitely. Between definitely (E) and possibly (C), pick definitely. The answer is (E).

9. **B** Again, use your knowledge of the main idea to help guide you. You can therefore eliminate (A) and (E). Does the English system continue to evolve? Use common sense—no. You are left with (B) and (C). The passage specifically mentions a variety of sources. (B) is the best answer. (C) is less good because it emphasizes the length of history instead of the quality of that history.
10. **A** You've established that the history of the English system is long and colorful. In the second passage, the author is also interested in history. So she/he would probably not happily agree that that history is less interesting. But there are dates in both passages. The English system goes back to the sixteenth century. Even if you forget that's actually the 1500s, you still know it's before 1840. So the history is factually shorter. That makes the answer (A).
11. **D** Go back to the reference to the French Revolution in the passage. The author specifically mentions its anti-traditionalist bent. So (D) looks good. She/he doesn't go so far as to indicate that the greatest accomplishment of the French Revolution was the metric system. Eliminate (A). The author indicates that the metric system was in keeping with the rest of the revolutionary thinking. So eliminate (B). There's no mention of the revolutionary calendar in the passage. Eliminate (C). (E) is the only tricky wrong answer. The passage says the metric system wasn't adopted in France until 1840, but it doesn't say it wasn't fully *invented* before then. The answer is (D).
12. **C** In the sentence in question, you find that it has been called, or *dubbed*, "voluntary" and "preferred." The implication is these are some sort of official designation, but they specifically are not required. Choice (C) sounds like a reasonable, noncommittal paraphrase. Eliminate (D). These words also don't suggest any pending official adoption. Eliminate (B). (A) overstates the case in the other direction: the view of the metric system reflected in the sentence in the passage is favorable. (E) overstates how favorable—the words in the passage are warm but don't suggest "superiority." The answer is (C).
13. **E** *Refined* in the passage is synonymous with recalculated. The passage doesn't say whether it's to make the meter smaller or bigger. That only leaves (E).

14. **B** There is no indication of any ideological shift motivating the 1983 move. That eliminates (A), (C), and (E). Which is more logical: new calculations of the Earth's circumference or new ways to calculate fractions? The former, especially where the speed of light is involved. The answer is (B).
15. **A** As soon as you find an answer that isn't addressed in one passage, you're done. Do both passages mention kings who were ruling at the time of their invention? No. Passage 2 talks about the French Revolution, which overthrew the king; it only mentions a king in regards to the English system. Choice (A) is the answer.
16. **A** Which of the answers is something that the author of Passage 2 would agree with but does not explicitly state? Which is most plausible? Choice (A) is the most reasonable answer on its face. You can find evidence for it when the author says *It is the great asset of the metric system, at least for scientists, that units for measuring weight and energy are also derived from the basic unit of the meter and The adoption of the metric system, also known as the international system, or S.I., coincided with great advances in science.*

Section 7

1. There is nothing fancy about this problem. Substitute and solve for x .

$$2y = 12$$

$$y = 6$$

$$2\sqrt{x} + \sqrt{x} = y$$

$$2\sqrt{x} + \sqrt{x} = 6$$

$$3\sqrt{x} = 6$$

$$\sqrt{x} = 2$$

$$x = 4$$

2. The first five even integers are 2, 4, 6, 8, and 10. Rev up that calculator start multiplying. The answer is 3,840.
3. If the probability that a senior would be picked is three-eighths, then seniors are three-eighths of the entire student body. Since Rider High has 400 students, the equation would be:

$$400 \times \frac{3}{8} = \frac{1200}{8} = 150$$

4. The volume of any rectangular solid is the length times the width times the height. The figure tells us the width and the height, and you can determine the length from what you know about the area of the shaded side. Start with the area of a rectangle formula and you can find the length:

$$A = l \times h$$

$$24 = 4 \times l$$

$$6 = l$$

Place this length of 6 into the volume formula for the box:

$$V = l \times h \times w = 3 \times 4 \times 6 = 72$$

5. First use the area of a circle formula to determine the radius.

$$A = \pi r^2$$

$$16\pi = \pi r^2$$

$$\frac{16\pi}{\pi} = \frac{\pi r^2}{\pi}$$

$$16 = r^2$$

$$4 = r$$

The diameter of a circle is twice the radius, so the diameter is 8.

6. There are some fancier ways to solve this problem, but the surest way is to count up the options. She could have:

1. No toppings.
2. Just a
3. Just p
4. Just r
5. a and p
6. a and r
7. p and r
8. All the toppings.

That is a total of 8. Sure, there's a fancier math way of handling this problem, but since you have the right answer, what does it matter? Is your SAT score in any way determined by whether you used the "fancy method" or not?

7. If x is the sum of the five numbers, you know:

$$\frac{\text{sum}}{\text{number of items}} = \text{Average}$$

$$\frac{x}{5} = 16$$

$$(5)\frac{x}{5} = 16(5)$$

$$x = 80$$

Make y the number taken away from the set y . You know that 80 minus y is the new sum, and that the new average is 14. With this information you can solve for y using the equation:

$$\frac{80 - y}{4} = 14$$

$$(4)\frac{80 - y}{4} = 14 (4)$$

$$80 - y = 56$$

$$80 - 56 - y = 56 - 56$$

$$24 - y = 0$$

$$24 = y$$

8. Since the triangle is a right triangle, you can use the Pythagorean theorem to determine the third side of the triangle:

$$c^2 = a^2 + b^2$$

$$100 = 64 + b^2$$

$$36 = b^2$$

$$b = 6$$

If 6 is the length of one side of the square, the area of the square is the square of that, 36.

9. You need to remember the right formula for this one. At least you know that since you can't grid in negative numbers, the slope must be positive. Here's the rise over run calculation:

$$\text{slope} = \frac{\text{rise}}{\text{run}} = \frac{y_1 - y_2}{x_1 - x_2} = \frac{-2 - 1}{-1 - 3} = \frac{-3}{-4} = \frac{3}{4}$$

10. If you work backward from what you know, this problem contains no difficult steps. If Bo is 15 and Gina is five years younger than he, then Gina is 10. And if Gina is 10 and Susan is three times the age of Gina, then Susan is 30. And if Susan is 30 and Tom is twelve years older than Susan, then Tom is 42. There's your answer, 42.
11. This one tries to intimidate you with a new symbol and a complicated definition. By now, this sort of attempted distraction should not even faze you, as you are well aware that everything you need to know about the new symbol is right in front of you.

The phrase *greatest prime divisor* means the greatest number that is prime and also divides the original number. So the greatest prime divisor of 15 is 5 since no prime numbers greater than 5 evenly divide into 15. As for 12, the greatest prime divisor is 3. This means $(15^*)(12^*) = (5)(3) = 15$.

12. The graph might look messy, but you only need to pick out the five y -intercepts and add them up.

Line 1: at (0, 2)

Line 2: at (0, 1)

Lines 3 and 4: at (0, 0)

Line 5: at (0, -1)

Adding up these five y -values gives you: $2 + 1 + 0 + 0 - 1 = 2$

13. The problem says that the numbers are *distinct*, so none of the four numbers are the same. That's your first clue. Since the sum of the four numbers is 26, the numbers in the sum must be less than 21. Here's a Rogue's Gallery List of all the less prime numbers: 2, 3, 5, 7, 11, 13, 17, and 19. To find the greatest possible integer in the set, first make all the other integers as least as possible. The set could be 2, 3, 5, x . This would maximize x . Now solve:

$$2 + 3 + 5 + x = 21$$

$$10 + x = 21$$

$$10 - 10 + x = 21 - 10$$

$$x = 11, \text{ also prime.}$$

11 must be the answer.

Section 8

As you might expect, answers will vary. If possible, politely ask a teacher, fellow student, or some other person knowledgeable about formal essay writing to review your essay and provide feedback on ways in which the essay is commendable and on areas where it could be improved.

Scoring Worksheet

MATH			
	Number Correct	Number Incorrect	Raw Score
Section 2	_____	– (.25 × _____)	= _____
Section 5	_____	– (.25 × _____)	= _____
Section 7	_____	– (.25 × _____)	= _____
CRITICAL READING			
Sections 1, 4, and 6	_____	– (.25 × _____)	= _____
WRITING			
Section 3	_____	– (.25 × _____)	= _____
Section 8	Go to www.petersons.com/satessayedge/ for instant online scoring and feedback.		

Score Charts

MATH			
Raw Score	Math Scaled Score	Raw Score	Math Scaled Score
60	800	28	500
59	800	27	490
58	790	26	490
57	770	25	480
56	760	24	470
55	740	23	460
54	720	22	460
53	710	21	450
52	700	20	440
51	690	19	430
50	680	18	420
49	670	17	420
48	660	16	410
47	650	15	410
46	640	14	400
45	630	13	390
44	620	12	380
43	610	11	370
42	600	10	360
41	600	9	350
40	590	8	340
39	580	7	330
38	570	6	320
37	560	5	310
36	560	4	300
35	550	3	280
34	540	2	270
33	540	1	250
32	530	0	240
31	520	-1	220
30	510	-2	210
29	510	-3 and below	200

CRITICAL READING			
Raw Score	Verbal Scaled Score	Raw Score	Verbal Scaled Score
78	800	37	510
77	800	36	510
76	800	35	500
75	790	34	500
74	780	33	490
73	770	32	490
72	760	31	480
71	750	30	480
70	740	29	470
69	730	28	460
68	720	27	460
67	710	26	450
66	700	25	450
65	700	24	440
64	690	23	440
63	680	22	430
62	670	21	420
61	670	20	410
60	660	19	410
59	650	18	400
58	640	17	390
57	640	16	380
56	630	15	380
55	620	14	370
54	610	13	360
53	610	12	360
52	600	11	350
51	600	10	340
50	590	9	330
49	590	8	320
48	580	7	310
47	570	6	300
46	570	5	290
45	560	4	270
44	550	3	260
43	550	2	250
42	540	1	240
41	540	0	230
40	530	-1	220
39	520	-2	210
38	520	-3 and below	200